

Model 9815A
CALCULATOR

SERVICE MANUAL

HEWLETT  PACKARD

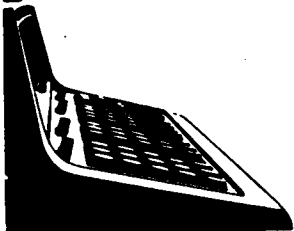

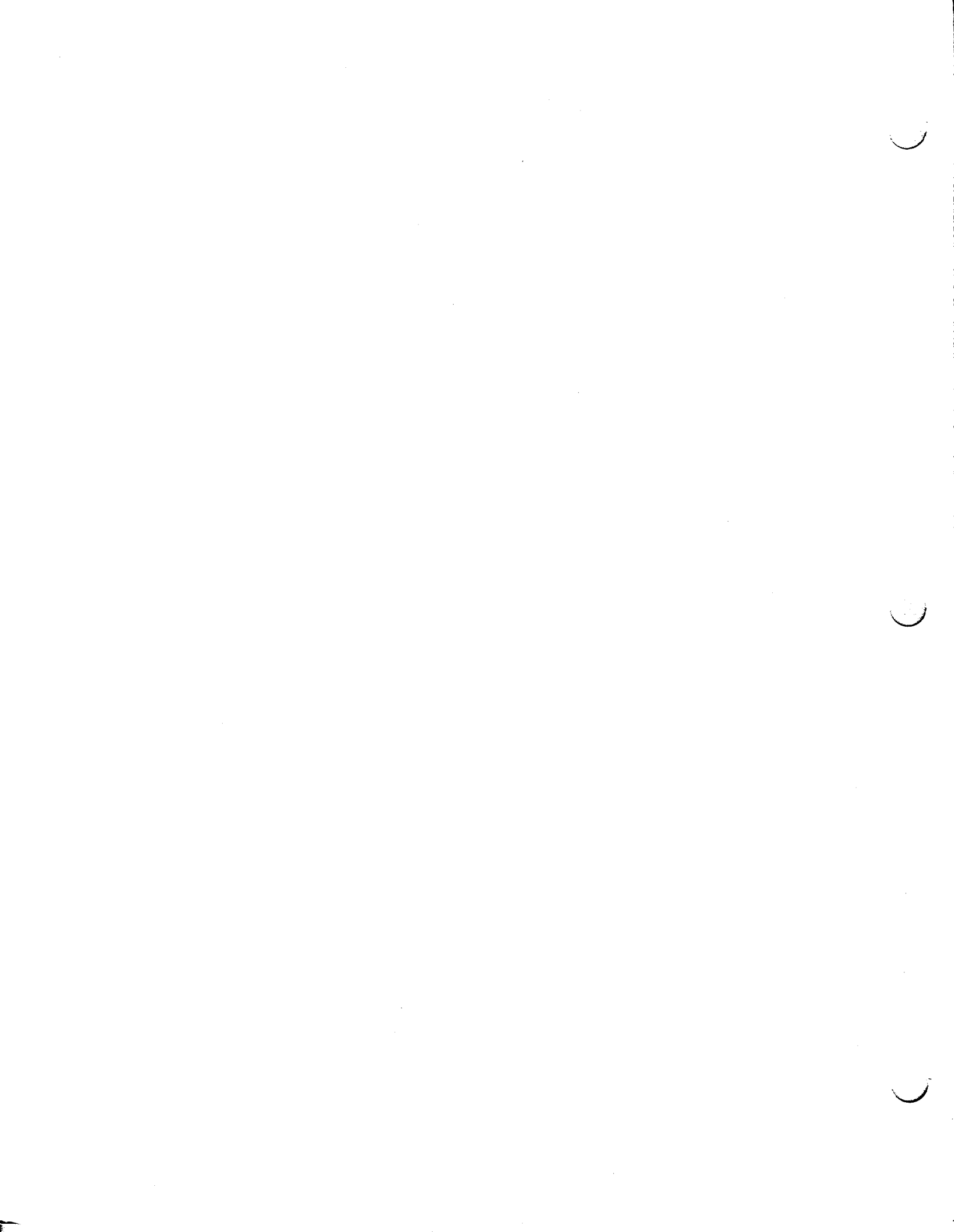

**Model 9815A
CALCULATOR**

SERVICE MANUAL

-hp- Part No. 09815-90030

HEWLETT-PACKARD CALCULATOR PRODUCTS DIVISION

P.O. Box 301, Loveland, Colorado 80537, Tel. (303) 667-5000

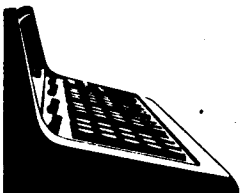

TABLE OF CONTENTS

CHAPTERS

CHAPTER 1: GENERAL INFORMATION

INTRODUCTION	1-1
CALCULATOR SERVICE KIT	1-1
OPTIONS	1-1
9815A INSTALLATION	1-1
OPTION INSTALLATION	1-3

CHAPTER 2: INSTRUMENT MAINTENANCE

INTRODUCTION	2-1
CALCULATOR CLEANING	2-1
ASSEMBLY ACCESS	2-2
ASSEMBLY CONSIDERATIONS	2-8
PRINTER MAINTENANCE	2-9

CHAPTER 3: TROUBLESHOOTING

INTRODUCTION	3-1
THEORY OF OPERATION	3-1
CALCULATOR CIRCUITS	3-4
UTILITY AND TEST CARTRIDGE (09815-10004)	3-4
PERIPHERAL TESTS	3-9
THE 9815A TEST ROM ASSEMBLY (98140-66501)	3-9
TAPE CARTRIDGE CONSIDERATIONS	3-13

CHAPTER 4: REPLACEABLE PARTS

INTRODUCTION	4-1
--------------------	-----

FIGURES

Voltage Selector Switches	1-2
Loading Printer Paper	1-3
Option 001 Installation	1-4
Option 002 Installation	1-5
Option 002 Connection	1-5
Cleaning the Tape Head	2-1
Calculator Access Screws	2-2
Removing the Processor Assembly	2-3
Removing the Option 001 RAM Assembly	2-3
Removing the Peripheral Control Assembly	2-4
Removing the Printer	2-5
Cartridge Drive Unit and Power Module	2-6
Removing the Fan	2-7
Display Filter	2-8
Calculator Test Setup	2-9
Printer Adjustment	2-10
9815A Block Diagram	3-3
Power Supply Schematic Diagram (part of A50)	3-15
General I/O Interface Schematic Diagram	3-16
Calculator Cabinet Parts	4-1
Printer Replaceable Parts	4-4

TABLES

9815A Problem Chart	3-12
Replaceable Parts	4-2

1 GENERAL INFORMATION

SPECIFICATIONS

SHIPPING WEIGHT	7.7 KG	(17 LBS)
WEIGHT	5.9 KG	(13 LBS)
WIDTH	34.54 CM	(13.60 INCHES)
HEIGHT	10.16 CM	(4.00 INCHES)
DEPTH	34.29 CM	(13.50 INCHES)
OPERATING TEMPERATURE	5° C TO 40° C AMBIENT	
CARTRIDGE READ/WRITE SPEED	25.4 CM/SEC	(10 INCHES/SEC)
SEARCH SPEED	152.4 CM/SEC	(60 INCHES/SEC)
STANDARD MEMORY	512 PROGRAM STEPS (472 STEPS PLUS 10 DATA REGISTERS)	
THERMAL PRINTER DISPLAY	16 CHARACTER LINE, 5 × 7 DOT MATRIX 16 CHARACTER LINE, 7 SEGMENT GAS DISCHARGE	

CHAPTER 1

GENERAL INFORMATION

INTRODUCTION

This manual provides 9815A Calculator service information for HP Customer Engineers. This information will enable a board level repair of the 9815A Calculator. The various chapters in this manual include installation, maintenance, theory of operation and replaceable parts information. All information is presented assuming that you are familiar with calculator operation. The 9815A Calculator operating manual part number is 09815-90000.

CALCULATOR SERVICE KIT

The 9815A Calculator Service Kit (98140A) contains a complete, operational calculator and all optional accessories. Kits may be ordered from Calculator Products Division, Loveland and from GmbH. Replacement parts should be ordered from either CSC or PCE, whichever is appropriate.

The items included in the 98140A Service Kit are listed in the 9815A Study Reference Guide. Also, an IOSM describing the 9815A service policy can be found in the study reference guide.

OPTIONS

The 9815A may be fitted with the following options which are either factory or field installable. Field installation is described later in this chapter.

Option 001 - Expanded memory; increases the 9815A memory from 512 steps to 2008 steps.

Option 002 - I/O Buffer; provides two I/O connectors on the calculator rear panel for external peripheral equipment to be connected.

Labels indicating the options installed are located under the paper cover.

9815A INSTALLATION

Power Requirements

The calculator will operate on a line voltage of either 100V, 120V, 220V or 240V ac (+5, -10%). The line frequency must be within the range of 48 to 66 Hz (inclusive). The calculator requires a maximum of 75 voltamps with option 001 and 002 installed.

1 GENERAL INFORMATION

Fuses

WARNING
DISCONNECT THE AC POWER CORD BEFORE REMOVING OR INSTALLING
A FUSE.

The calculator fuse is located on the left side of the paper well. To access the fuse, lift the paper cover and remove the roll of paper from the paper well.

The calculator requires a 1.5 amp fuse for 100V or 120V ac operation, and a .75 amp fuse for 220V or 240V ac operation.

NOMINAL VOLTAGE	OPERATING RANGE (-10%, +5% OF NOMINAL)	CALCULATOR FUSE	HP PART NO.
100	90 to 105 volts	1.5A	2110-0043
120	108 to 126 volts	1.5A	2110-0043
220	198 to 231 volts	.75A	2110-0033
240	216 to 252 volts	.75A	2110-0033

Setting the Voltage Selector Switches

Ensure that the two voltage selector switches on the rear panel are set to the correct powerline voltage. Figure 1-0 shows the correct settings for each nominal line voltage. If it is necessary to alter the setting of either switch, insert the tip of a small screwdriver into the slot on the switch. Slide the switch so that the position of the slot corresponds to the desired voltage, as shown.

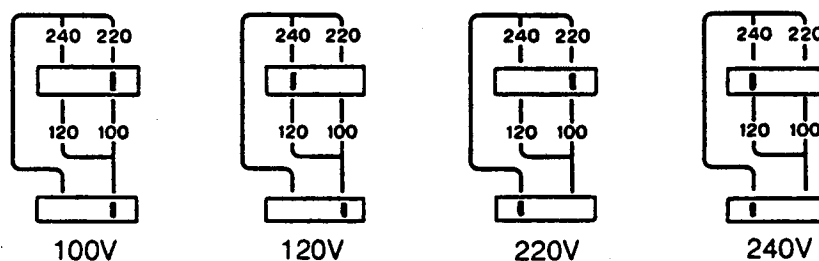

Figure 1-0. Voltage Selector Switches

Printer Paper

To install the printer paper, use the following procedure.

- Lift the paper cover.
- Insert the metal spindle through the center of the roll of paper.
- Position the spindle in the guides so that the paper will unwind from the bottom of the roll (see Figure 1-1).
- Insert the end of the paper into the slot in the front of the paper well and turn the printer's thumb wheel to advance the paper through the printer.

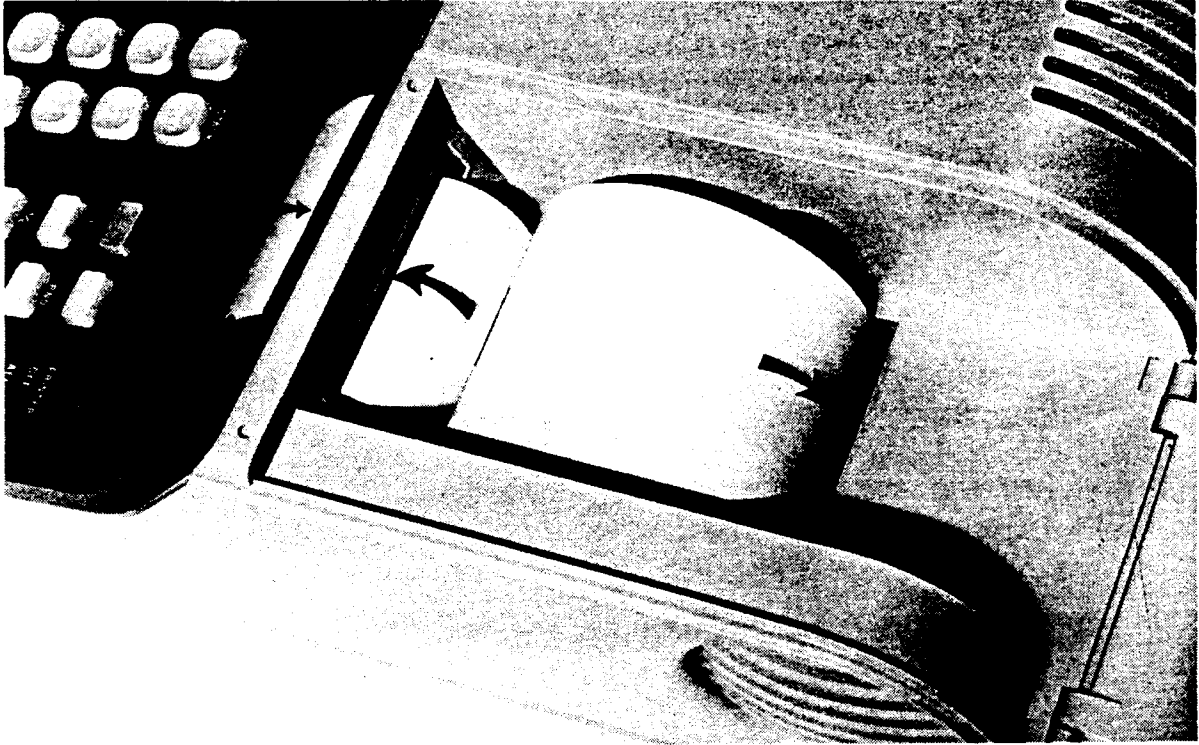

Figure 1-1. Loading Printer Paper

Cartridge Installation

To install a tape cartridge, open the tape drive door, slide the cartridge into the drive with the front of the cartridge facing forward and close the door.

To remove the cartridge, press the cartridge eject bar.

OPTION INSTALLATION

The following procedures describe the field installation of options 001 and 002. You should read the assembly access section in Chapter 2 to become familiar with the calculator construction before installing any option.

Option 001 Expanded Memory

Option 001 increases the Read/Write memory to 2008 steps.

The Option 001 kit is the 98121A. This kit contains one RAM assembly (09815-66581), one connector block (1251-4011) and one "OPTION 001" label (7120-3630).

To install option 001, first remove the top cover and the keyboard assembly (refer to the assembly access section in Chapter 2).

- Place the option RAM assembly (A81), component side up, on the back of the A10 processor assembly (see Figure 1-2). Ensure that the connector block is correctly installed between the PC assemblies.
- Connect the keyboard and place it on the calculator.
- Put the fuse in, plug the calculator in and turn it on.

1 GENERAL INFORMATION

- Place the mode switch to program. The number in the display on the right should be 1928 (no external peripherals connected). 1928 is the number of program steps available.
- Install the Test Cartridge and perform the memory test (see Chapter 3); then remove the cartridge.
- Reassemble the calculator.
- Install the option label under the paper cover.

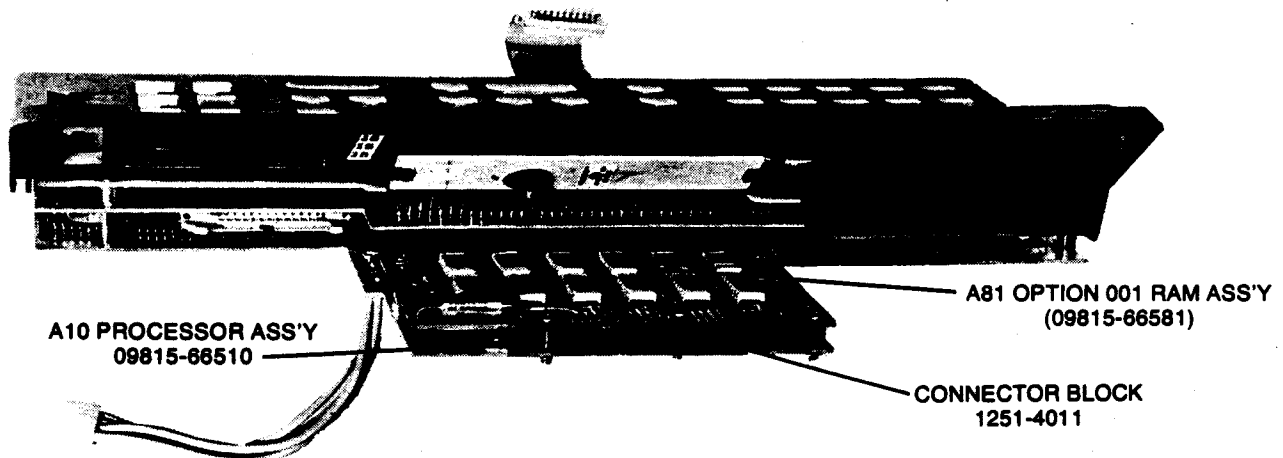

Figure 1-2. Option 001 Installation

Option 002 Input/Output Buffer

The Option 002 kit is the 98122A. This kit contains the following items:

Description	Quantity	Part Number
I/O Assembly	1	09815-67501
I/O Manual	1	09815-90002
I/O Cover	1	5040-7849
Option 002 Label	1	7120-3631

To install option 002, first remove the top cover and the keyboard assembly.

- Remove the right side panel.
- Fasten the I/O assembly to the right side panel with the hardware provided (see Figure 1-3).
- Fit the I/O assembly and side panel into place in the calculator.
- Connect the 2-wire nylon connector as shown in Figure 1-4. This connector is color coded for correct installation.
- Bend and position the two ribbon connectors as shown in Figure 1-4.
- Reinstall the keyboard assembly (remember to connect the new connectors) and the top cover.
- Perform the I/O Test: Requires the Test Assembly, the I/O Test Fixture and the 09815-10004 Test Cartridge (see Chapter 3).
- Install the option label under the paper cover.

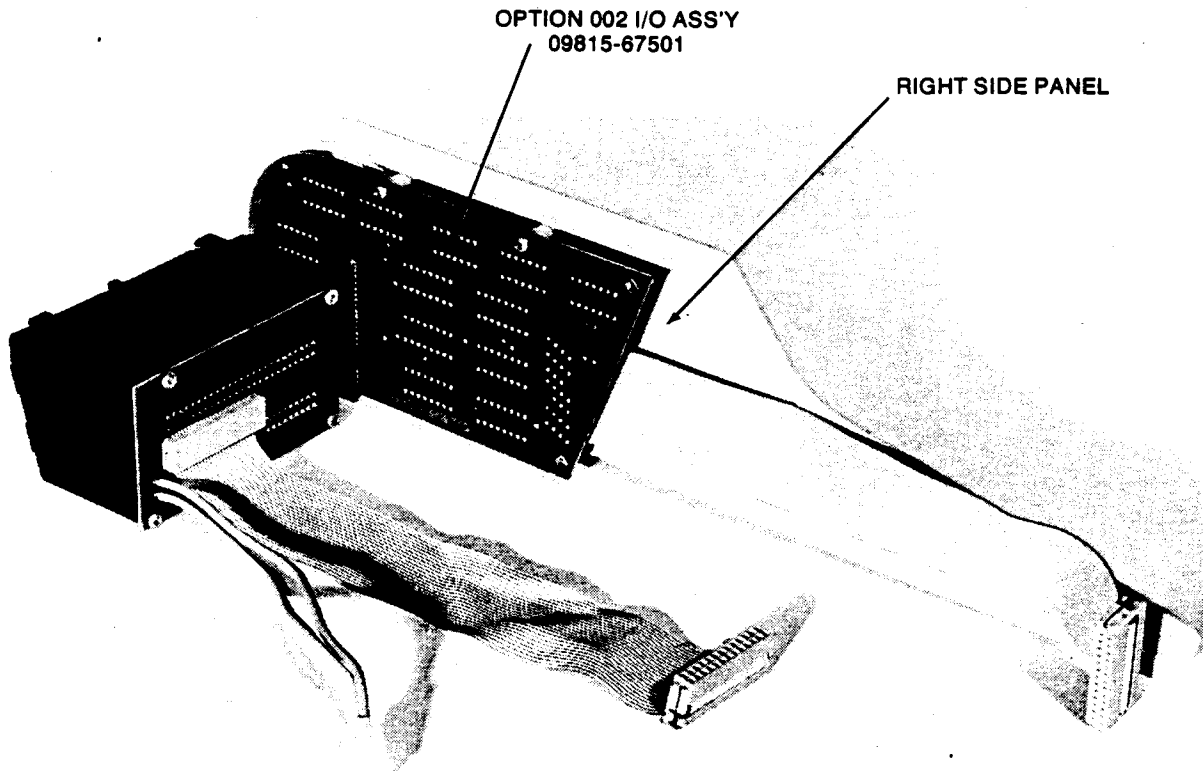

Figure 1-3. Option 002 Installation

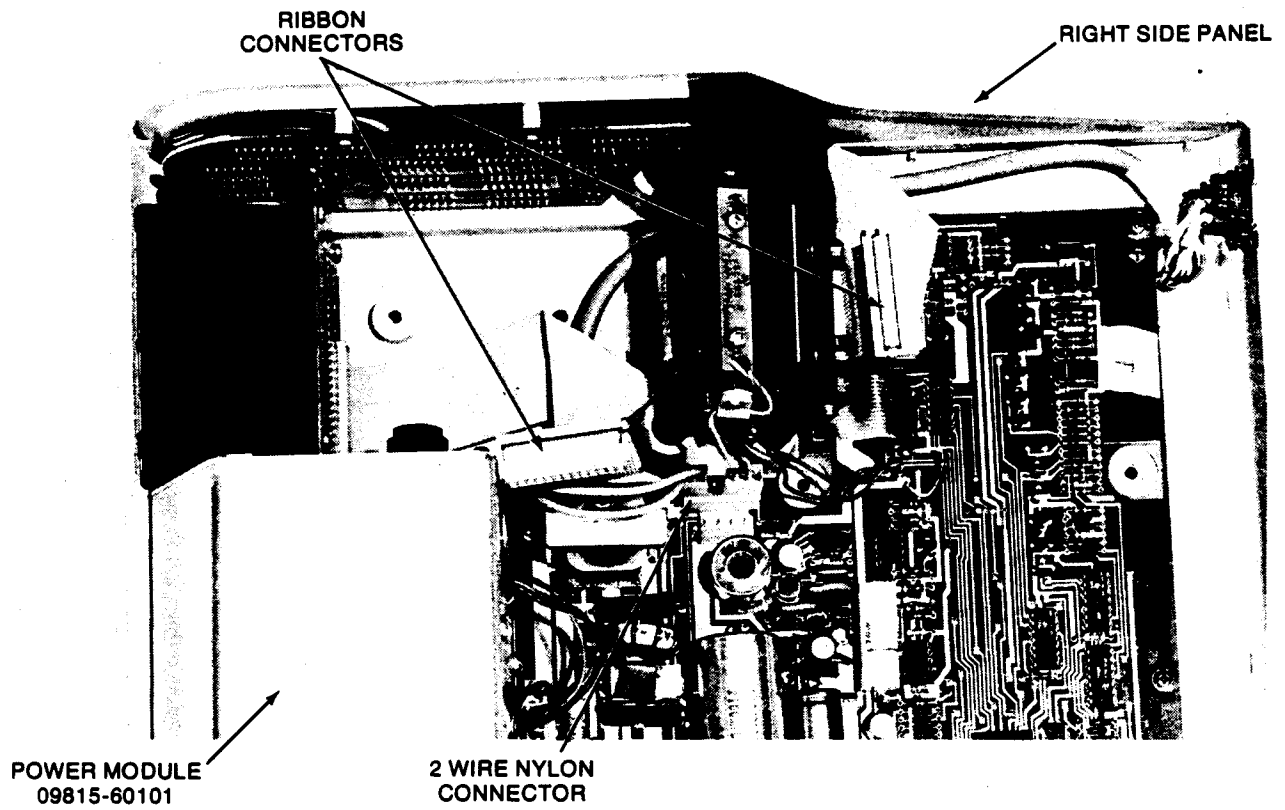

Figure 1-4. Option 002 Connection

1 GENERAL INFORMATION

NOTES

CHAPTER 2

INSTRUMENT MAINTENANCE

INTRODUCTION

This chapter describes how to clean the calculator, access the calculator assemblies, and make calculator adjustments.

CALCULATOR CLEANING

The calculator case can be cleaned by using a soft, moist cloth. Do not use harsh or abrasive detergents, and do not allow moisture to penetrate the calculator.

Fan Filter

The fan filter is on the left side of the calculator. Just pull it out to remove it. Clean the filter in warm soapy water and rinse it in clean water; then dry it thoroughly.

Magnetic Tape Head

To ensure the reliability of tape operation, it is recommended that the tape head be cleaned after every eight hours of tape operations. It's a good idea to clean the tape head before making important recordings.

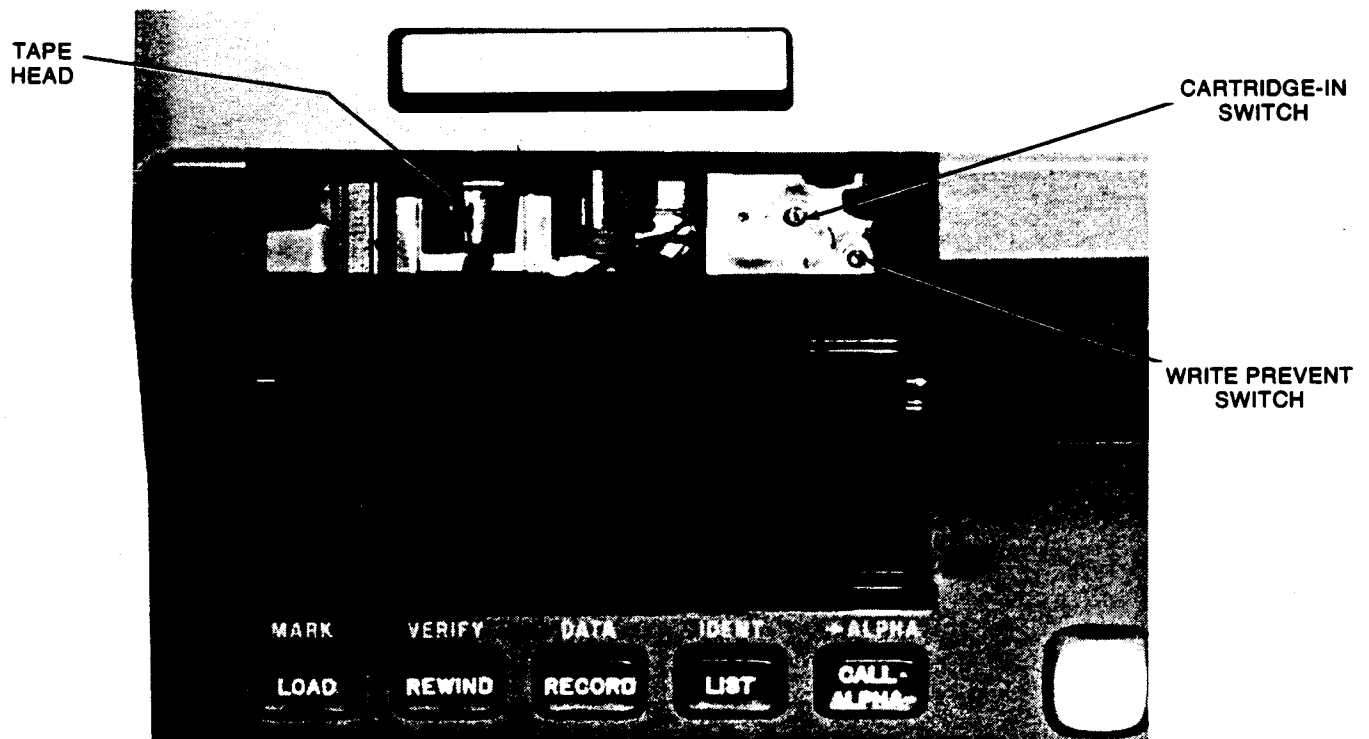

Figure 2-Ø. Cleaning the Tape Head

2 INSTRUMENT MAINTENANCE

The tape head is cleaned as follows:

1. Open the tape-drive door and remove the tape cartridge.
2. Clean the tape head with a cotton swab that has been dampened with head cleaning solution (see Figure 2-8). Wipe the top of the tape head a few times with the cotton swab. Remove any other dust that has accumulated in the vicinity of the tape head.

ASSEMBLY ACCESS

Top Cover and Keyboard Assembly

To access any calculator assembly, the keyboard assembly and the top cover must be removed; use the following procedure.

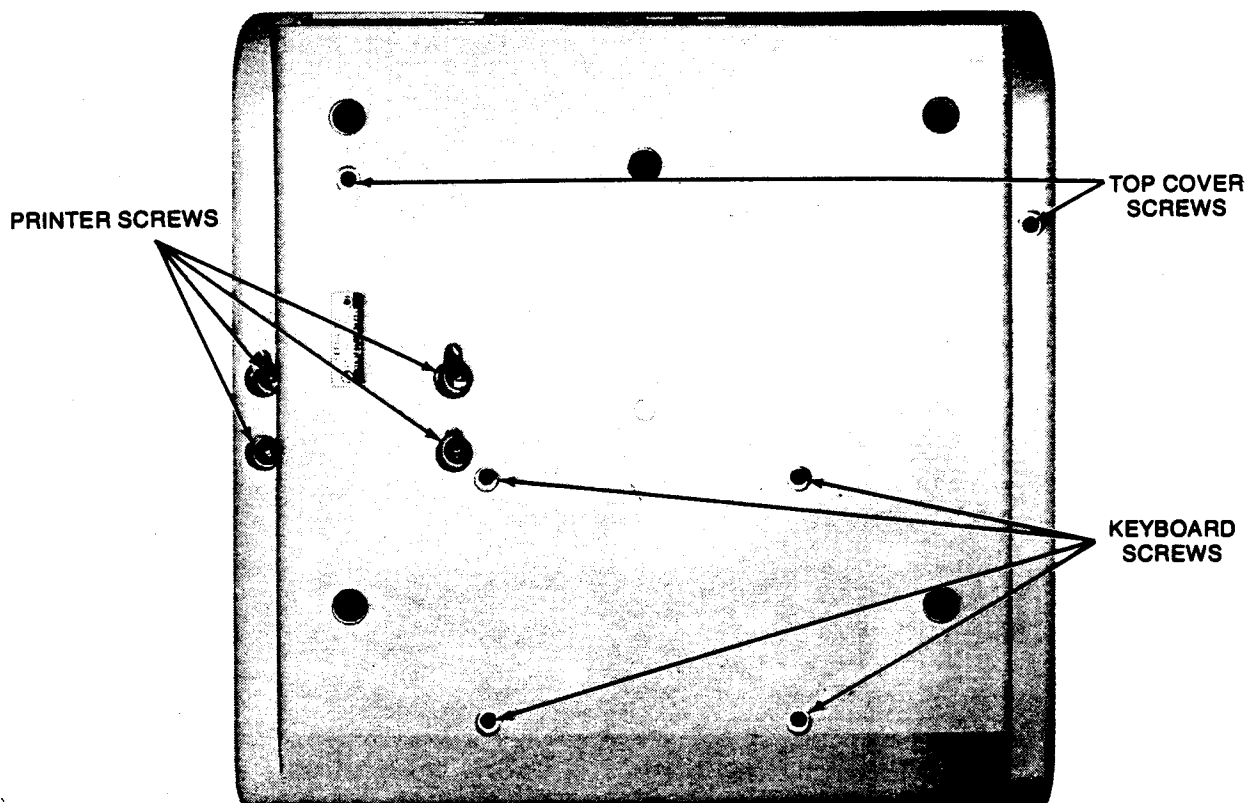

Figure 2-1. Calculator Access Screws

- Disconnect the ac power cord.
- Remove the printer paper and tape cartridge.
- Remove the fuse cap and fuse.
- Remove the access screws, shown in Figure 2-1, that hold the keyboard and top cover to the calculator.
- Lift the keyboard slightly and remove the top cover from the calculator.
- If the I/O Option (Option 002) is installed, remove the two I/O ribbon connectors from the keyboard assembly (Figure 1-4).

- Disconnect the 4-wire nylon connector from the power supply assembly.
- Disconnect the keyboard assembly's ribbon connector from the power supply assembly, and remove the keyboard from the calculator.

A10 Processor Assembly (09815-66510)

The processor is attached to the keyboard assembly. 5 long screws and 1 short screw hold the A10 Processor assembly to the keyboard assembly. Note that a connector block (see Figure 2-2) is positioned between the A10 Processor and the Peripheral Control Assembly (A0). This block must be correctly positioned when installing the A10 assembly.

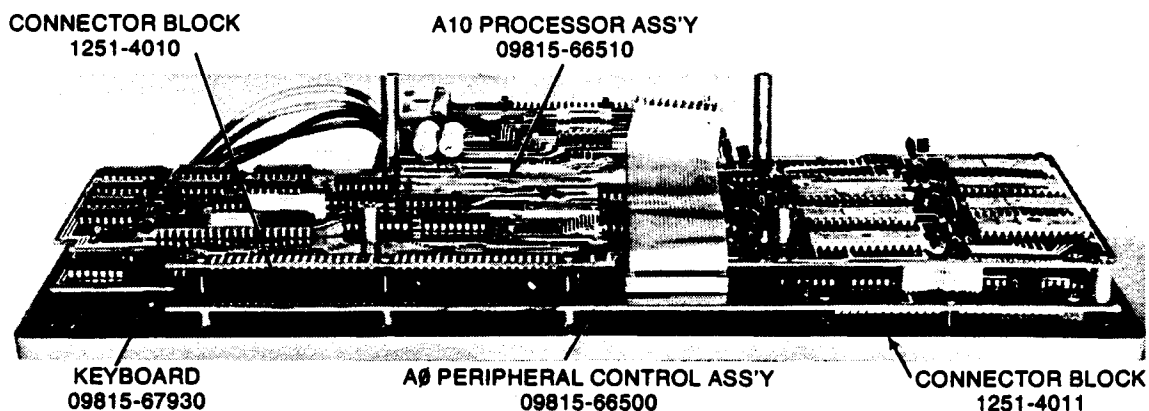

Figure 2-2. Removing the Processor Assembly

A81 Option 001 RAM Assembly (09815-66581)

The optional RAM assembly (A81) is attached to the A10 processor. Once the keyboard assembly is removed from the calculator, the 5 screws and 3 nuts holding the A81 assembly to the processor can be removed. Note that a connector block (see Figure 2-3) is positioned between A10 and A81. This block must be correctly positioned when installing the A81 assembly.

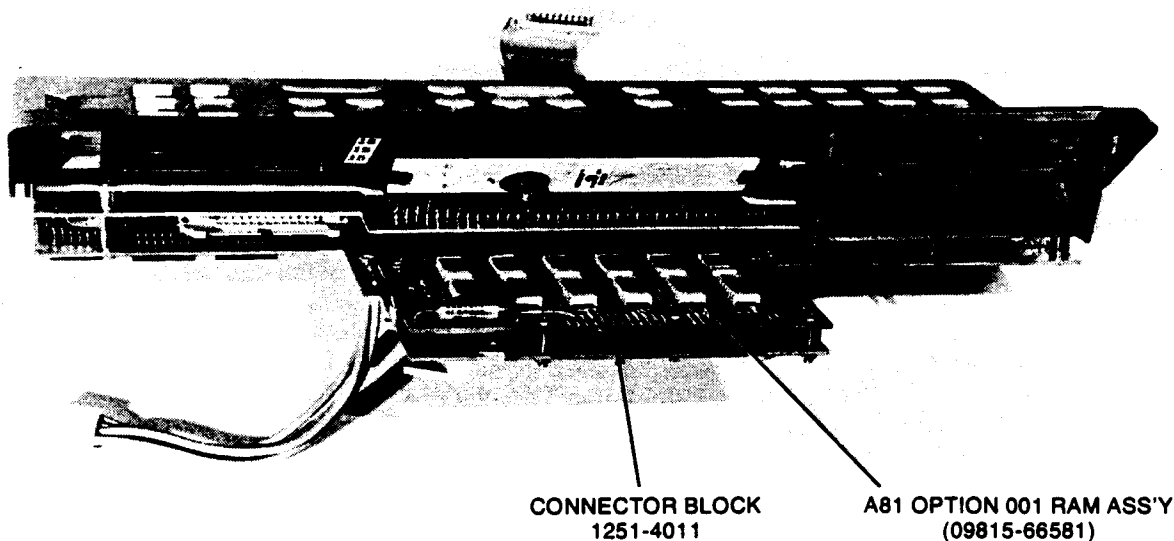

Figure 2-3. Removing the Option 001 RAM Assembly.

2 INSTRUMENT MAINTENANCE

AØ Peripheral Control Assembly (09815-66500)

The Peripheral Control Assembly (AØ) is the PC assembly closest to the keyboard. The display tube is connected to the AØ assembly.

- First remove the A10 processor assembly.
- Remove the screws that hold the AØ assembly to the keyboard. Note that a connector block (see Figure 2-2) is positioned between AØ and the keyboard.
- Carefully guide the display tube out of the display window guides (see Figure 2-4) and remove the AØ assembly.
- Remove the display tube from the display connector.

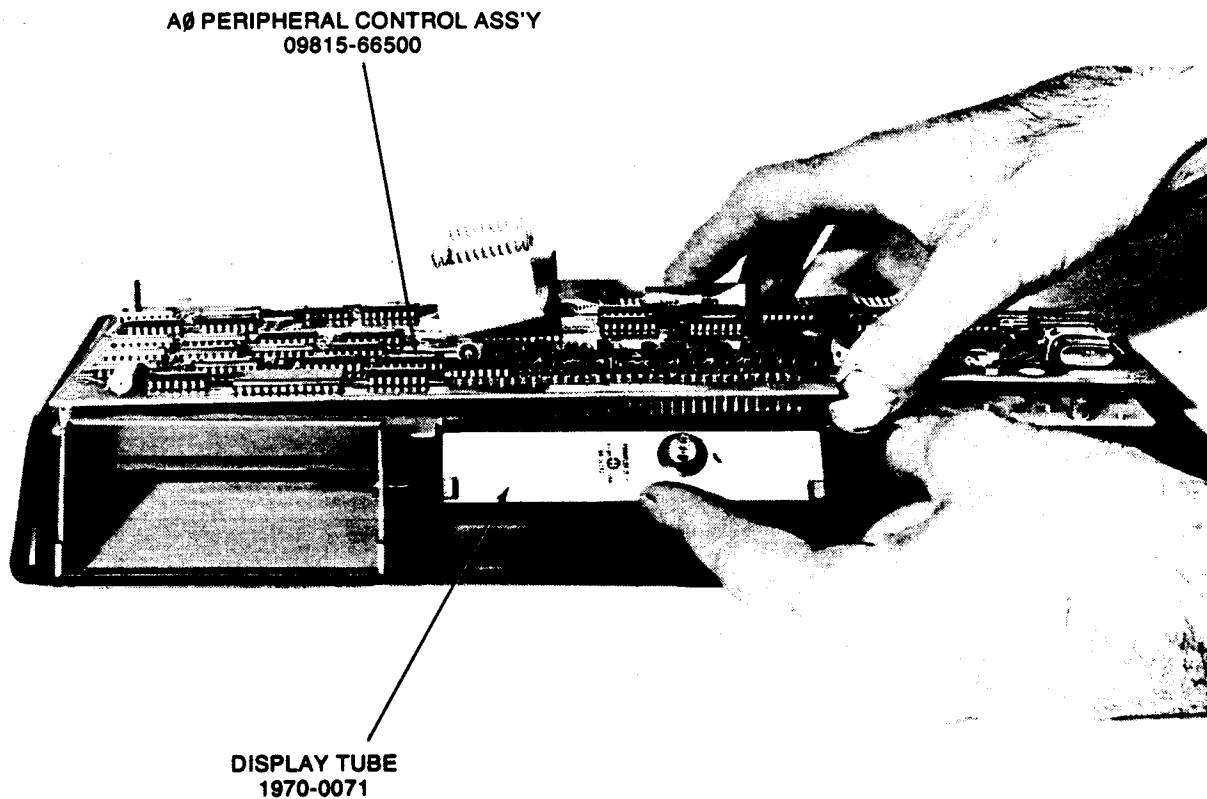

Figure 2-4. Removing the Peripheral Control Assembly

Keyboard

After the A10 and AØ assemblies have been removed, the keyboard may be substituted or the display window can be replaced if it is scratched. The amber display filter is polarized and must be installed correctly; see Assembly Considerations later in this chapter.

Printer

- Disconnect the 2 wires and the 2 connectors that connect the printer to the power supply assembly (see Figure 2-5).
- Then remove the 4 screws that hold the printer to the bottom cover (Figure 2-1).

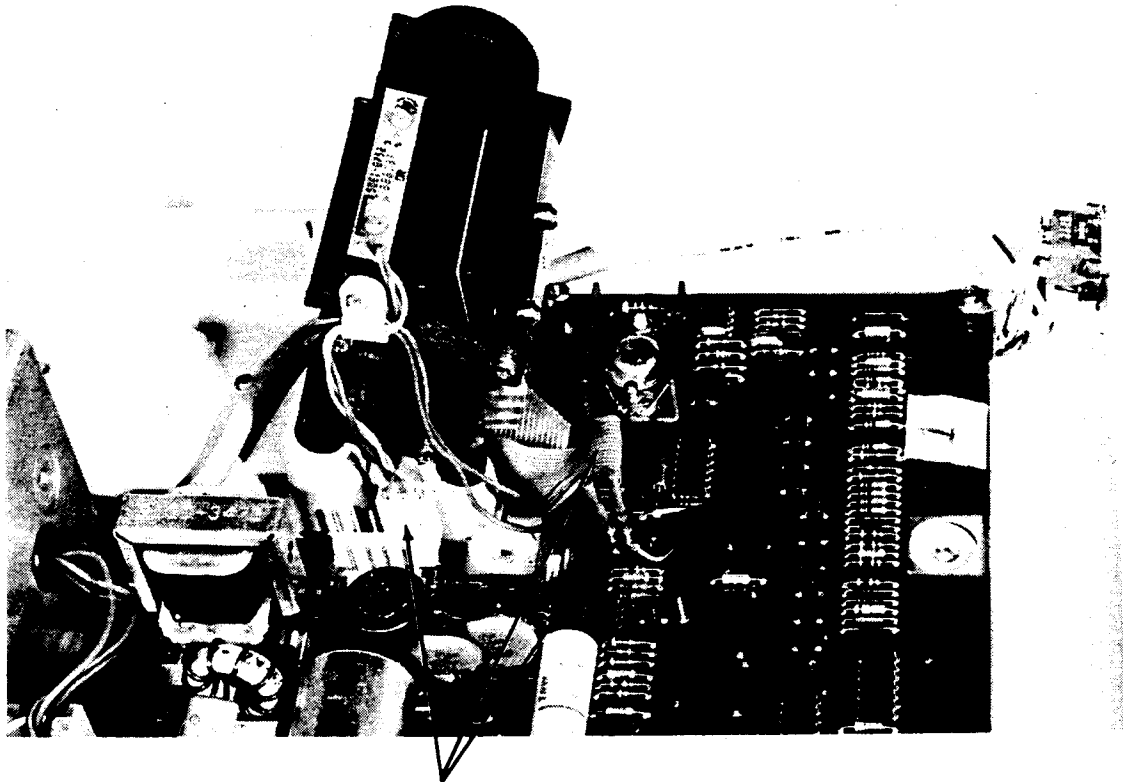

**PRINTER
CONNECTORS**

Figure 2-5. Removing the Printer

2 INSTRUMENT MAINTENANCE

Cartridge Drive Unit

The cartridge drive unit and its control PC assembly are one assembly.

- First remove the 2 screws that hold the PC assembly in place (see Figure 2-6).
- Disconnect the control assembly from the power supply assembly and remove the cartridge drive unit and the left side panel from the calculator.
- Remove the 2 screws that hold the cartridge drive to the drive bracket. The bracket stays with the side panel.

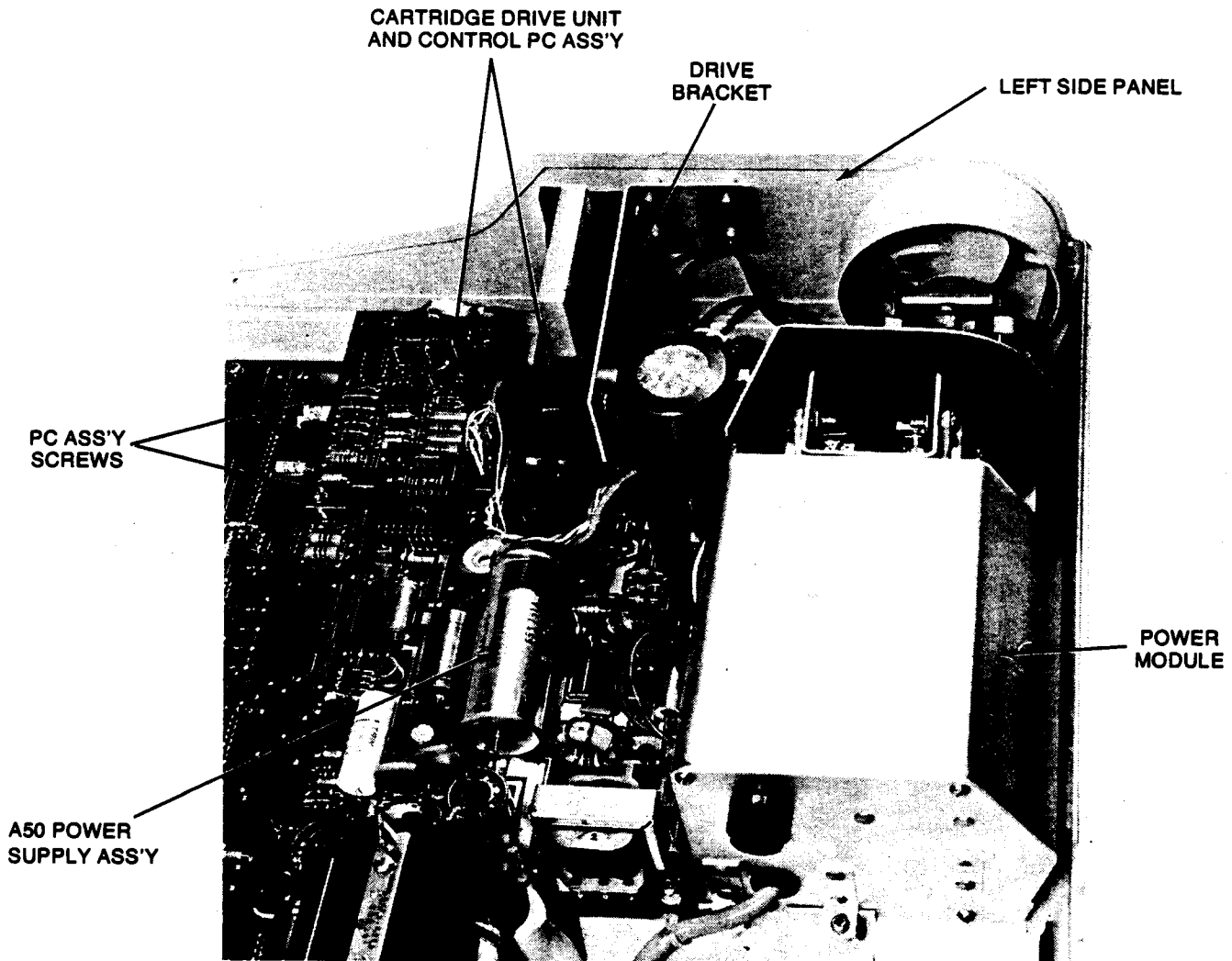

Figure 2-6. Cartridge Drive Unit and Power Module

Fan

To remove the fan, move the left side panel out as shown in Figure 2-7. Remove the 2 screws that hold the fan to the bottom cover and disconnect the fan connector.

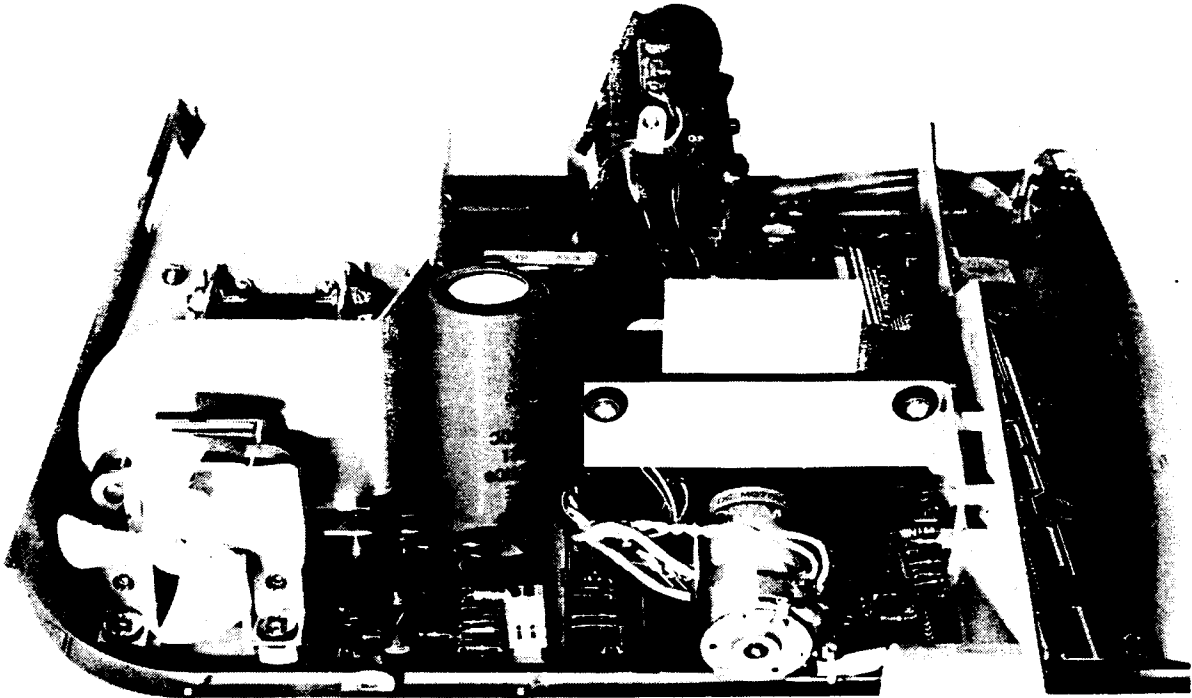

Figure 2-7. Removing the Fan

Primary Power Module

The primary power module shown in Figure 2-6 is removed by removing the 5 screws that hold the module to the bottom cover. Disconnect the module connector and remove the module.

I/O Buffer Assembly (Option 002)

Disconnect the 2-wire connector from the power supply assembly (see Figure 1-4); then lift the I/O buffer and the right side panel off the calculator.

(A50) Power Supply Assembly

The power supply assembly can be removed after removing the cartridge drive unit. Be sure to disconnect the various connectors which connect to the A50 assembly.

2 INSTRUMENT MAINTENANCE

ASSEMBLY CONSIDERATIONS

Not all of the 9815A assemblies go together as easily as they come apart. The assemblies that require special notice during assembly are listed with the special actions required for each assembly.

Cartridge Drive Unit

- When installing the drive unit, ensure that the fan shroud on the left side panel does not contact the fan. After installation, rotate the fan to ensure that it turns freely.
- Be sure the drive unit is seated in its guide which extends up through the power supply assembly (A50).

I/O Buffer (Option 002)

- When installing the I/O Buffer, ensure that the 2-wire, white, nylon connector is properly connected. If this connector is reversed, damage to interface ROMs will result.
- Ensure that the ribbon cable on the I/O Buffer's 66501 assembly is routed along the side of the printer, not over the top of the printer.
- Both I/O buffer ribbon-cable connectors are plugged in with the cables pointed to the bottom of the instrument as shown in Figure 1-4.

Display Filter

The amber display filter is polarized. When replacing the filter, check the polarization as follows.

- Place the filter over the display tube (out of the instrument), and note the darkness of the display character traces. (See Figure 2-8).
- Turn the filter over and make the same observation.
- The side which looks the darkest should face the outside when installed.

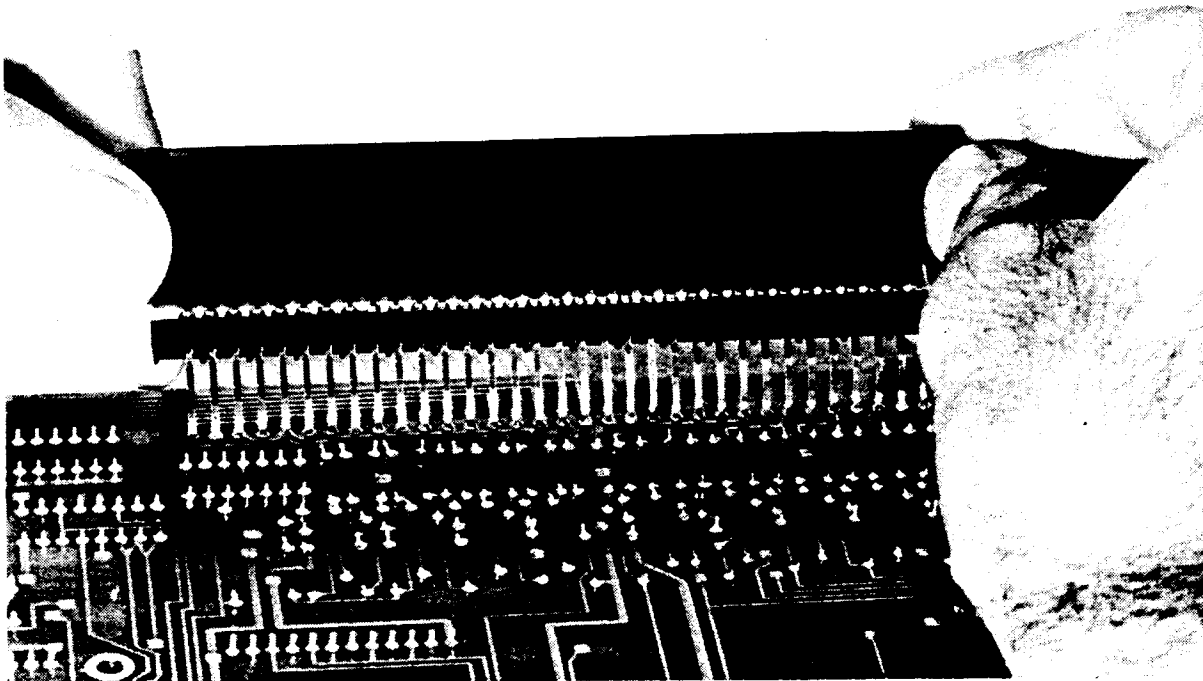

Figure 2-8. Display Filter

Display Tube

When installing the display tube, first install the tube on its connector on the AØ assembly. As the AØ assembly is installed, guide the display tube into the guides on the display window. It may be necessary to gently lift the front edge of the tube over the keyboard tabs.

Connector Blocks

When putting the PC assemblies together, don't forget to put the connector blocks in between the assemblies; as shown in Figures 2-2 and 2-3.

PRINTER MAINTENANCE

Printer Test Setup

The following setup procedure can be used when performing printer maintenance and repair.

- Remove the top cover and keyboard assembly.
- Install the fuse and fuse cap and load the printer with paper.
- Connect the keyboard assembly to the power supply assembly (see Figure 2-9).
- Install an extender cable (HP Part No. 98140-61601) to extend the 4-wire cable from the keyboard assembly to the power supply assembly (see Figure 2-9).
- Install the test cartridge (HP Part No. 09815-10004).
- Load and run the printer test (see Chapter 3).

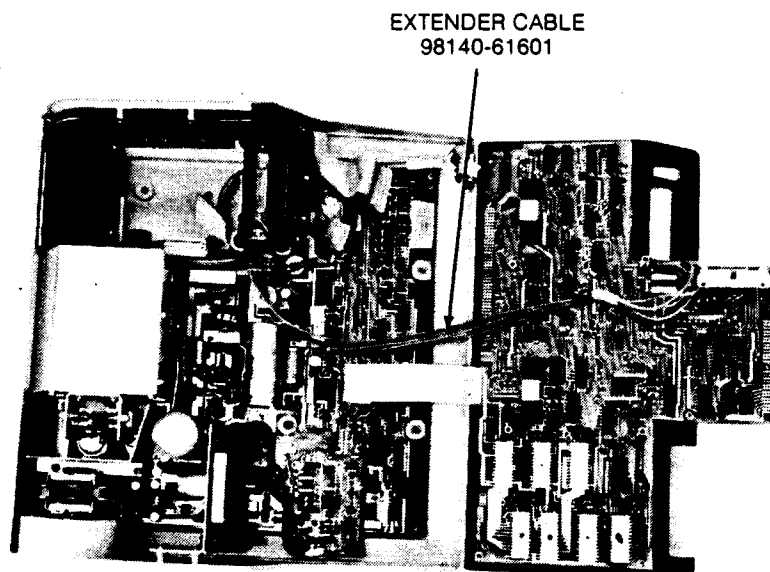

Figure 2-9. Calculator Test Setup

2 INSTRUMENT MAINTENANCE

Printer Intensity

While the print test is running, a clear, crisp printout with uniform intensity should be seen.

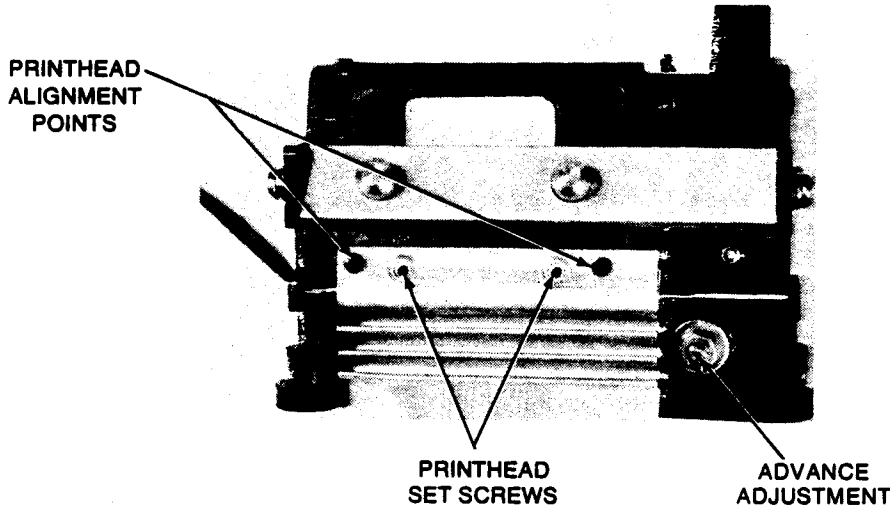

Figure 2-10. Printer Adjustments

Paper Advance

The paper advance adjustment is set at the factory and normally will not require adjusting. Adjustment is made only if the character height is greater than normal. If necessary, here is the procedure:-

- Loosen the lock nut on the advance adjustment screw (see Figure 2-10).
- While the print test is running, turn the adjustment screw clockwise until the printer stops advancing paper.
- Slowly turn the adjustment screw counter-clockwise until the printer just begins to advance without missing line spaces (normal character height).
- Continue to turn the screw another $\frac{3}{4}$ turn counter-clockwise and tighten the lock nut without altering the setting.
- Seal the adjustment screw with a drop of glue or paint.

Print Heads

The print head is labelled with a voltage value. A padding resistor (R11) located on the A50 power supply assembly (see component locator, Figure 3-2) should correspond to the voltage value. A chart showing the corresponding resistor value for each print head voltage is given below.

Print Head Voltage Value	R11 Padding Resistor Value
14.9V	7.32K
15.1V	7.15K
15.3V	6.98K
15.5V	6.81K
15.7V	6.65K

When replacing a print head, tighten the print head set screws snugly but do not overtighten. Excessive tightening of the set screws may warp the aluminum heat sink causing it to bind.

Print Head Alignment

Intensity variations and horizontal skew of the printout are usually caused by the print head being incorrectly positioned. The print head can be aligned by the following procedure:

- Loosen the print head set screws.
- Insert the two print head alignment tools (8710-0693) into the alignment holes (Figure 2-11).
- While the printer test is running, rotate the alignment tools to adjust the print head up and down until the best print quality is obtained.
- Stop the printer test and tighten the print head set screws.
- Start the printer test again to recheck the setting.

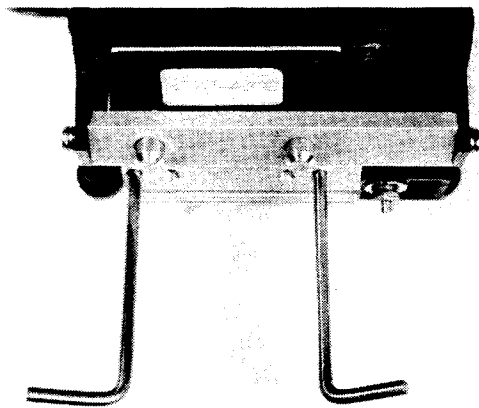

Figure 2-11. Print Head Alignment

CHAPTER 3

TROUBLESHOOTING

INTRODUCTION

This chapter includes a brief theory of operation, block diagram, the test ROM routines, and the test cartridge programs. This information is sufficient to troubleshoot and repair the 9815A Calculator using the 98140A Service Kit.

To troubleshoot the calculator, first determine which assembly is defective by installing the test cartridge*, and running the test programs (in any order). The customer's description of the problem will help you.

Refer to the 9815A Problem Chart (Table 3-1) and the "Calculator Circuits" presentation to determine which calculator assembly to replace.

Besides the test cartridge (09815-10004), a test ROM assembly (98140-66501) is provided in the service kit. The ROM will act as a backup method of testing the calculator. Most of the ROM programs are duplicated on the test cartridge. If the test cartridge is not available, use the test ROM. Read the descriptions of the test cartridge and the test ROM in this chapter to become familiar with the tests.

THEORY OF OPERATION

The 9815A block diagram is shown in Figure 3-1. The hardware can be classified into two main groups. The first group consists of the Micro-Processing Unit (MPU) and its associated memory and the second group includes the peripheral hardware and the necessary interfacing (PIA) to the MPU group.

The MPU interfaces with memory and peripherals via an 8-bit, bi-directional, instruction-data bus. The MPU is capable of directly addressing the Read/Write memory via an address bus. The MPU synchronizes memory operations by confirming that a valid memory address is on the address-bus. Two interrupt requests are used on the MPU, IRQ is used by the peripheral keyboard and NMI is used by the peripheral cassette. A two-phase clock is required by the MPU for dynamic operation and instruction-data synchronization.

The 9815A mainframe ROMs (2048 eight-bit words each) provide data and instructions for the MPU. The coincidence of two signals is necessary to initiate a memory access to ROM. First the address bus is decoded to provide a chip select and secondly a start memory signal is provided to synchronize the ROM's drivers on the 8-bit, instruction-data bus.

An I/O ROM on each interface card provides the instructions necessary to drive external peripherals. The I/O ROMs are accessed through an input buffer which also multiplexes input data (from external peripherals) onto the MPU's 8-bit, instruction-data bus.

Read/Write memory for the 9815A is provided by static N-mos RAMs. Each RAM contains 256, 4-bit words. The basic 9815A has 512, 8-bit user R/W steps for user program storage. A "base page" RAM is used by the 9815A as a scratch-pad memory. An additional 1536-step user R/W option is also available.

To take advantage of the MPU's fastest instruction addressing mode, four address locations of base page memory are used to transfer data to and from the Peripheral Interface Adapter (PIA).

*The Utility and Test Cartridge (09815-10004) contains both applications and test programs. Only the test programs are described in this chapter.

3 TROUBLESHOOTING

The 9815A uses the PIA to output 12 bits of data and 4 control bits to the 9815's internal peripherals. The PIA also has 4 handshake lines which provide the system synchronization between the MPU and the internal and external peripherals.

The 9815A clock circuit generates a 4mHz clock which is divided by 4 to provide the system 1mHz clock.

The 1mHz clock is separated into two non-overlapping phases of equal period by the clock circuits. A "cycle steal" circuit is required for RAM memory access because the RAMs have a Read/Write access time greater than one clock period.

The bi-directional, instruction-data bus is connected to the N-mos ROMs, RAMs, PIA and the data input buffer. The MPU 16-bit address bus is connected to all memory devices and to the address decoder to provide memory chip-selects.

The Read/Write line of the MPU is sent to the PIA and RAMs.

General Purpose I/O Interface

The GIO assembly uses a ROM which contains the I/O instructions, the input data latch and the data-bus enabling circuits (see Figure 3-3). The I/O ROM is enabled when the correct address is placed on the address lines through the address decoder. Data from the interface and status of the interface are enabled onto the data bus by "ATS1" and "ATS2" (from the I/O Buffer assembly) so multiple data sources are not on the data bus at the same time.

Power Supply

When the power switch (S1) is turned on, ac voltage is supplied to the primary of the transformer through switches S2 and S3 (see Figure 3-2). These switches are used to change the configuration of the primary wiring of the transformer so that the secondary voltage is the same for all four ac line voltages: 100, 120, 220, and 240 Volts. The transformer secondary has a filter stage to reduce conducted interference on the line. A full wave rectifier bridge is used to provide a positive and negative raw voltage for the power supplies.

The +15V supply uses a series pass regulator Q1. The value of R11 can be changed to set the voltage between +14.7 and +15.9V. This supply uses a current limit circuit, U1.

The +12V supply uses a series pass regulator (Q7) with a zener diode (CR4) providing the voltage reference.

The +5V supply uses a switching regulator (U2) which compares the output voltage with a reference voltage and in turn switches transistors Q5 and Q15. The reference voltage is provided by R17.

The -5V supply uses a series-pass regulator (Q6) with CR3 providing the voltage reference.

The -12V supply uses a series-pass regulator (Q3) with current limit circuitry (Q2, Q9). CR1 provides the reference voltage.

CAUTION

DO NOT OPERATE THE 9815A POWER SUPPLY (09815-66550) WITHOUT A LOAD. THE KEYBOARD ASSEMBLY MUST BE CONNECTED TO THE 66550 ASSEMBLY TO PROVIDE A LOAD WHEN SERVICING THE POWER SUPPLY.

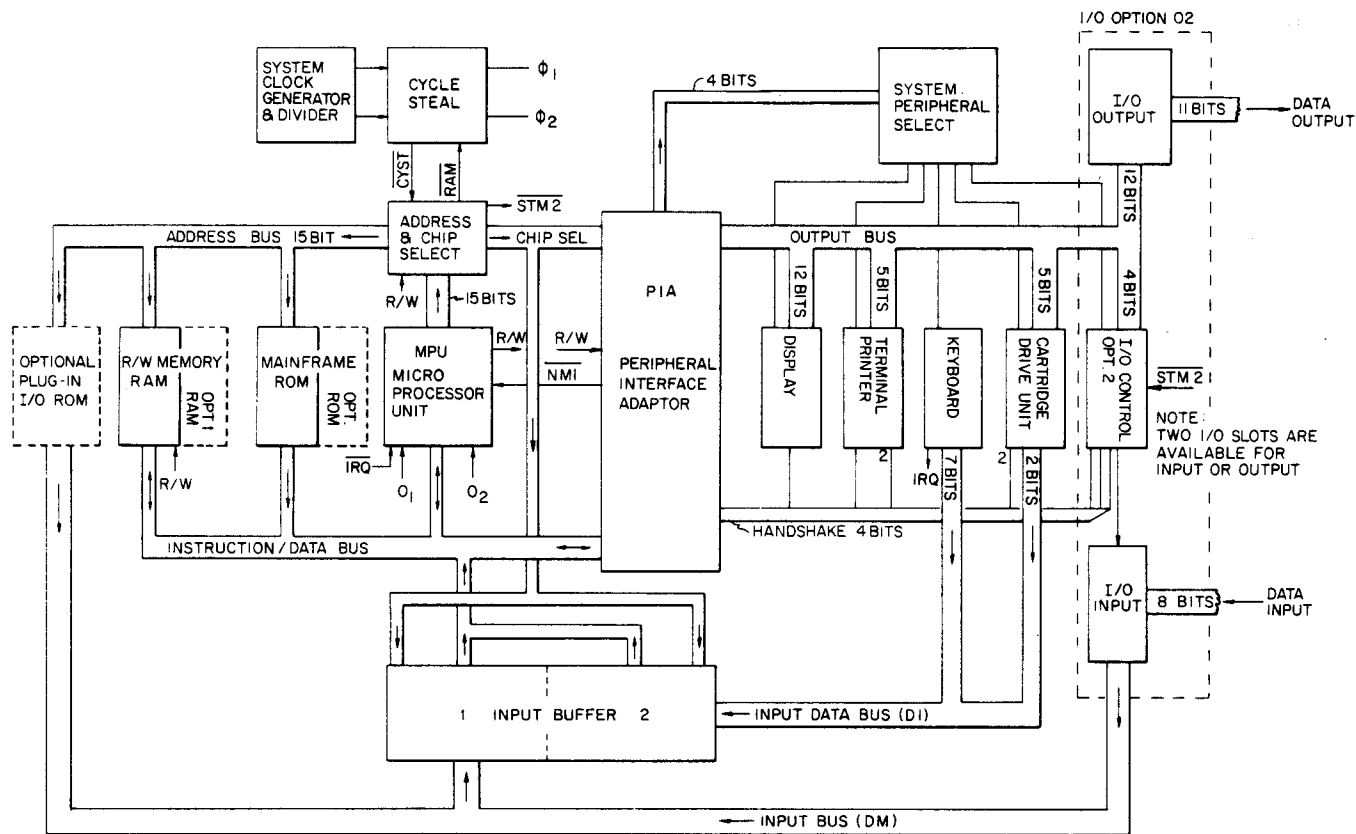

Figure 3-1. 9815A Block Diagram

3 TROUBLESHOOTING

CALCULATOR CIRCUITS

Although complete schematics of the calculator are not available, a knowledge of which circuits are on a particular PC assembly and the Test Cartridge will be sufficient to isolate a faulty assembly. The calculator's PC assemblies are listed below with the circuits found on each assembly. Also, refer to the Problem Chart (Table 3-1).

Power Supply Assembly (A50)

- \pm 12V supply
- \pm 5V supply
- -100V display HV supply
- Printer advance drive
- Printer paper out
- Cartridge motor drive amplifier
- Cartridge data read amplifier.

Peripheral Control Assembly (A0)

- Display drivers and decoders
- Keyboard decoding
- System clock and clock dividers
- Cartridge frequency detector
- Peripheral select

Processor Assembly (A10)

- Micro Processor
- Peripheral interface adapter
- ROMs
- RAMs
- Input data buffer
- Address and chip select

THE UTILITY AND TEST CARTRIDGE (09815-10004)

The Utility and Test Cartridge contains a complete set of calculator test programs. To run these tests, first load and run the test program directory by using the following procedure. The I/O Test is not listed in the directory, but the procedure is given after the directory tests.

1. Open the tape drive door.
2. Slide in the cartridge, so that the label is right-side-up and facing you.
3. Set the printer switch to OFF and set the mode switch to AUTO START.

Switch the calculator OFF; then ON

The following printout will occur.

```

AUTO START

UTILITY & TEST
CARTRIDGE

FOR CALC. TESTS
PRESS (1)(RUN)
    
```

4. Press for the calculator tests. The following printout will occur.

```

9815A CALCULATOR
TEST EXERCISER
PROGRAMS

2008 PRGM STEPS?

1=YES
0=NO
    
```

5. If the calculator has 2008 program steps (Option 001), press:

- If the calculator has 472 program steps (basic memory), press:

6. The test directory is printed.

```

PRESS ONE OF
THE FOLLOWING
KEYS.

KEY      TEST
A        DISPLAY
B        PRINTER
C        KEYBOARD
D        ROM
E        MEMORY
F        COMPLETE
    
```

3 TROUBLESHOOTING

After the directory is printed, select the test by pressing the indicated key. Then compare your results with the following descriptions. Typical running times are listed with each.

Each test, except the Memory test, runs once and halts. The Memory test runs continuously until the calculator is switched off.

If you wish to run any test (except "Keyboard") continuously, press  **1** before pressing the indicated key.













NOTE
If MEMORY OVERFLOW is printed after the directory, the wrong memory size was indicated in step 5. Return to step 3 and reload the directory program.

Display Test (30 seconds)

Run this test to check each display digit and segment. The display sequence is shown below. The test is complete when 0 (n) is displayed.

When the test is run continuously, n indicates the number of completed tests. Press  once to halt the test.

The following steps will occur by pressing the  key to advance to the next step.

1. 
2. 
3. 
4. 
5. 
6. 
7. 
8. 
9. 
BLANK DISPLAY
10. 
- 11 THRU 26. 
ONE DIGIT AT A TIME IS CHECKED
27. 
ALL DIGITS LIT

Printer Test (25 seconds)

Compare your printout with the sample shown. Check for missing or extra dots and the length of the solid block of dots. When 0 is displayed, the test is complete.

When the test is run continuously, the display indicates the number of completed tests. Press  once to halt the test.

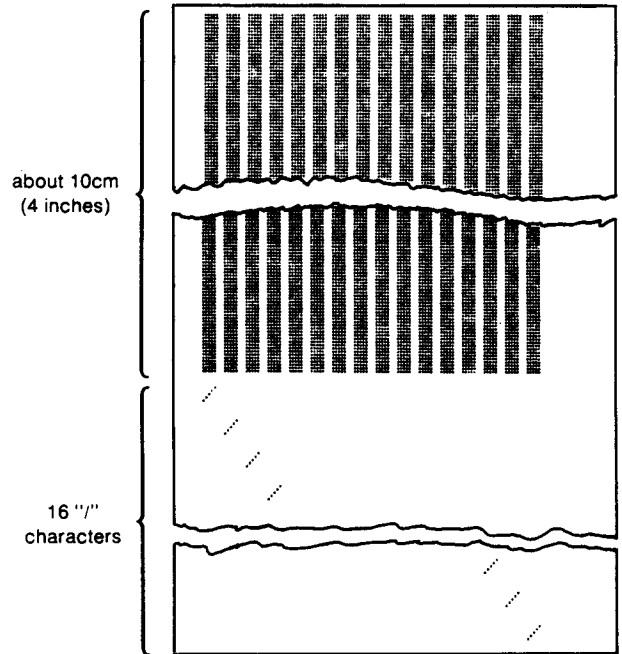

Keyboard Test (1 Minute)

This test checks each key and switch on the calculator keyboard. Set the printer switch to OFF. After pressing "C", wait for the tape drive to halt. Then perform the following.

1. Set the mode switch to RUN.
2. Set the printer switch to NORM.
3. Set the mode switch to PRGM.

"1" will be displayed.

After 1 is displayed, press each key once in the order shown by the next figure. The display increments as each key is pressed, indicating the next key to be pressed. If a key is pressed out of sequence, or if a key is defective, FAIL n is printed. n indicates either the correct key to press or the defective key.

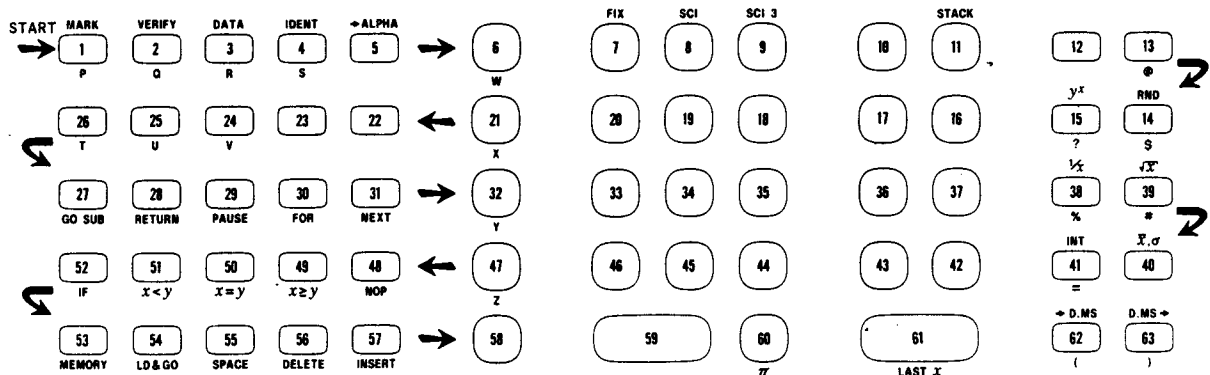

3 TROUBLESHOOTING

The final display is:

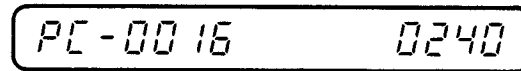

Now set the mode switch to RUN and the test is complete.

If FAIL n is printed repeatedly, restart the test by switching the calculator off and return to step 3 on page 3-4.

ROM Test (3 seconds)

This test checks all read-only-memories in the calculator and in any interfaces plugged in. The correct displays are shown below.



When the test is run continuously, n indicates the number of completed tests. Press  once to halt the test.



If FAIL n is displayed, an error has occurred.

Memory Test (5 seconds)

This test checks the program memory. When PASS is displayed, the test is complete. This test runs continuously until either  is pressed or the calculator is switched off. To run another test, reload the directory (see step 3 on page 3-4).

If FAIL n is displayed, an error has occurred.

Complete Exerciser (1 minute)

This key automatically runs the Display, Printer, ROM and Memory tests, one at a time (see the foregoing descriptions). Then the Memory test is automatically repeated until the calculator is switched off.

I/O Test

The I/O Test is used to check the circuits and signals used in data transfer to and from external peripherals.

This test requires that the Test ROM (98140-66501) and the I/O Test Fixture (98140-66502) be installed in the calculator's I/O slots. Either test assembly may be installed in any slot.

Set the printer switch to NORM and set the mode switch to RUN.

Press 250 shift store. If a memory overflow occurs, press 58 shift store.

Load the I/O test by pressing:



PASS will be displayed when the test is completed. Failures are printed out.

PERIPHERAL TESTS

The Utility and Test Cartridge has programs for checking operation of each calculator peripheral and its interface card.

Here is a list of peripheral tests, showing the manual in which user instructions are described.

Peripheral Test	File	For Instructions See
HP 9862A Plotter: Accuracy Test	-12	98132A Plotter Interface Operating Manual
Performance Test	-13	
HP 9863A Tape Reader	-17	Operating Note, P/N 098134-90011
HP 9864A Digitizer	-18	Operating Note, P/N 098134-90012
HP 9866A Thermal Printer	-19	Operating Note, P/N 098123-90013
HP 9871A Printer	-21	98131A Printer Interface Operating Manual
HP 9883A Tape Reader	-23	Operating Note, P/N 098134-90014
HP 9884A Tape Punch	-24	Operating Note, P/N 098134-90015

THE 9815A TEST ROM ASSEMBLY (98140-66501)

The 9815A Test Assembly contains binary programs to check the calculator's operation. The assembly contains the following programs.

- Static Read/Write Test (standard RAM), and ROM Checksum
- Static Read/Write Test (option RAM only)
- Keyboard Test
- Display Test

If the I/O option is not installed in the calculator, install the option 002 assembly found in the service kit. Remove your kit option 002 assembly after testing.

To install the test assembly plug it into one of the I/O slots on the calculator's rear panel.

The following presentation describes each ROM program and the procedures to use each program. If a failure occurs during any of the tests, refer to "Calculator Circuits" and the Problem Chart to determine which assembly is failing.

Static Read/Write Test (Standard RAM) and ROM Checksum

This test loads memory with patterns which detect open or shorted address lines and data lines, and bad memory locations. A checksum test is performed on all ROM's including any installed in the I/O slots.

To start the test, set the printer switch to OFF; then switch the calculator ON.

The display will show:

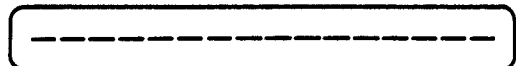

When the test has run completely "PASS 02FF" will be displayed. "OP PASS 08FF" is displayed if the option RAM is installed.

A failure is indicated on the printer; the location and the pattern that failed will be printed.

The test is continuous; to stop the test, switch the printer switch to NORM.

3 TROUBLESHOOTING

Static Read/Write Test (optional RAM only)

This test is the same as the standard RAM test except it is performed only on the option RAM assembly (A81).

To start the test, set the printer switch to ALL; then switch the calculator ON.

The display will show:



When the test has run completely "OP PASS 08FF" will be displayed.

A failure is indicated on the printer; the location and the pattern that failed will be printed.

The test is continuous; to stop the test, switch the printer switch to NORM.

Keyboard Test

This test checks the keyboard switches for proper operation. Each key is pressed in a sequence and errors are printed.

To start the test, first position the printer switch to NORM and position the mode switch to RUN.

Then call the program by pressing:



Now do the following:

- Move the mode switch to PRGM
- Move the printer switch to OFF
- Move the mode switch to RUN
- Move the printer switch to NORM
- Move the mode switch to PRGM

"1" should appear in the display.

Starting with the Load key in the upper left corner, press the keys one at a time in the sequence shown below.

NOTE
If the keys are pressed out of sequence an error printout will occur. To continue, press the key number that is indicated in the display.

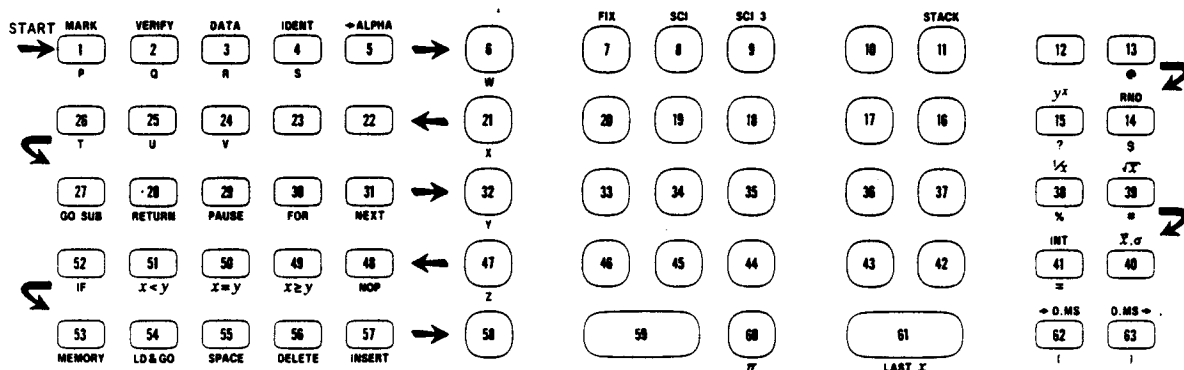

The number in the display indicates the next key to be pressed. The test ends after the last key has been pressed; the 9815A is now in the program mode.

Display Test

This test checks the display and display drive circuits for proper operation.

Position the print mode switch to NORM and the calculator mode switch to RUN.

To run this test, first call the program by pressing:  **7** 

By pressing C the display segments will be checked one at a time. Then all eights will be displayed. The various steps in this test are shown below. Press C for each step. The same segments on all digits will light as indicated by each step. Press  to stop the test.

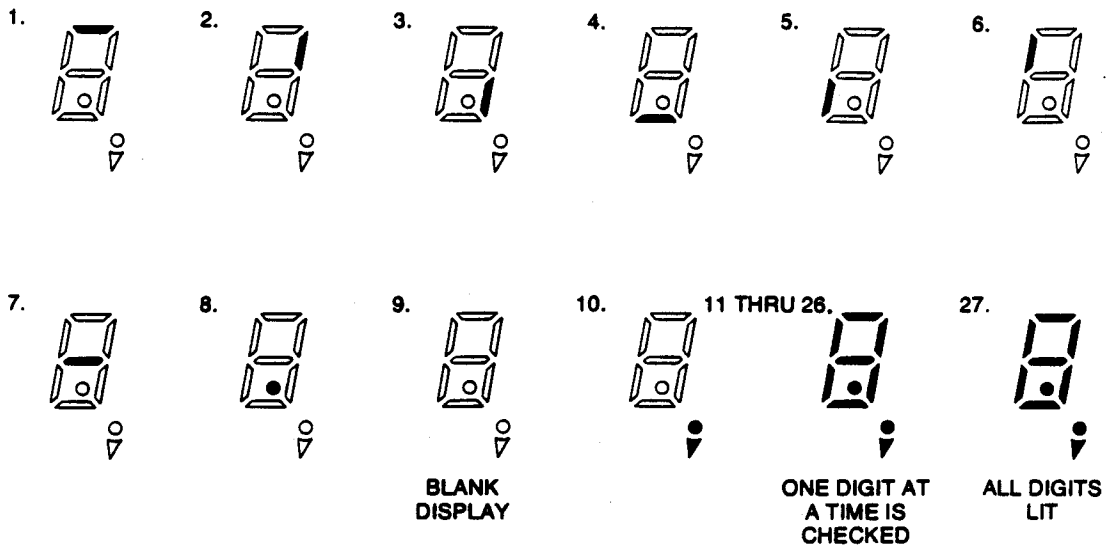

3 TROUBLESHOOTING

TABLE 3-1. 9815A PROBLEM CHART

CHANGE** PROBLEM	Option RAM (A81)	Keyboard	Processor (A10)	Peripheral Control	I/O Buffer (Opt 002)	Power Supply (A50)	Display Tube	Cartridge Drive	Printer	Power Module
	Fuse Blows						2			
Fuse OK Calculator Inoperative		3				2				1
Incorrect Display Digits Extra Segments Displayed or Missing Segments			3	2			1			
Keyboard Keys Inoperative or Keys Function Improperly		1	3	2						
Calculator OK Display Dark (Digits not visible)						2	1			
Cartridge Failure				3		2		1		
Printer Missing Dots or Extra Dots			3			2			1	
R/W Memory Failure	2		1							
ROM Failure			1							
I/O Problems			2	3	1					

**The numbers in the columns indicate the probability of assembly failure and the order in which to exchange assemblies. "1" is the most probable assembly to fail.

TAPE CARTRIDGE CONSIDERATIONS

The following describes tape cartridge anomalies and their cure.

- It is a good idea to remove a tape cartridge from the calculator when you are not using the calculator. If a cartridge is left in the calculator, a flat spot may develop on the friction drive wheel in the cartridge drive unit. This condition will cause errors when using the tape. The flat spot is only temporary, and may be corrected by running the tape forward to the end of tape, and then rewinding the tape.
- The tape drive belt may lose its tension with age. A loose drive belt is evident when the tape is not wound smoothly on the tape reels. This condition can be seen through the front of the cartridge. A cartridge with this condition should be replaced.
- If the tape unwinds completely from one of the reels, refer to the following drawing and use the procedure below to re-thread the tape.
 1. Remove the 4 screws holding the cartridge cover and remove the cover.
 2. Thread the tape around the guides as shown in drawing.
 3. Moisten the end of the tape so that it will stick on the tape reel.
 4. Using a sharp pencil, guide the end of the tape between the drive belt and the reel.
 5. As you wind the tape onto the reel, ensure that there is no slack in the tape. If the tape is not tight, start over again.
 6. Wind at least 10 turns of tape onto the reels.
 7. Reassemble the cartridge.

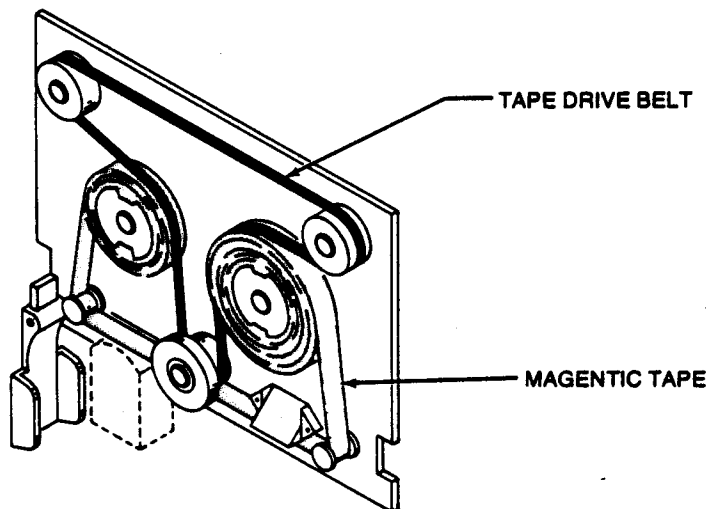

3 TROUBLESHOOTING

NOTES

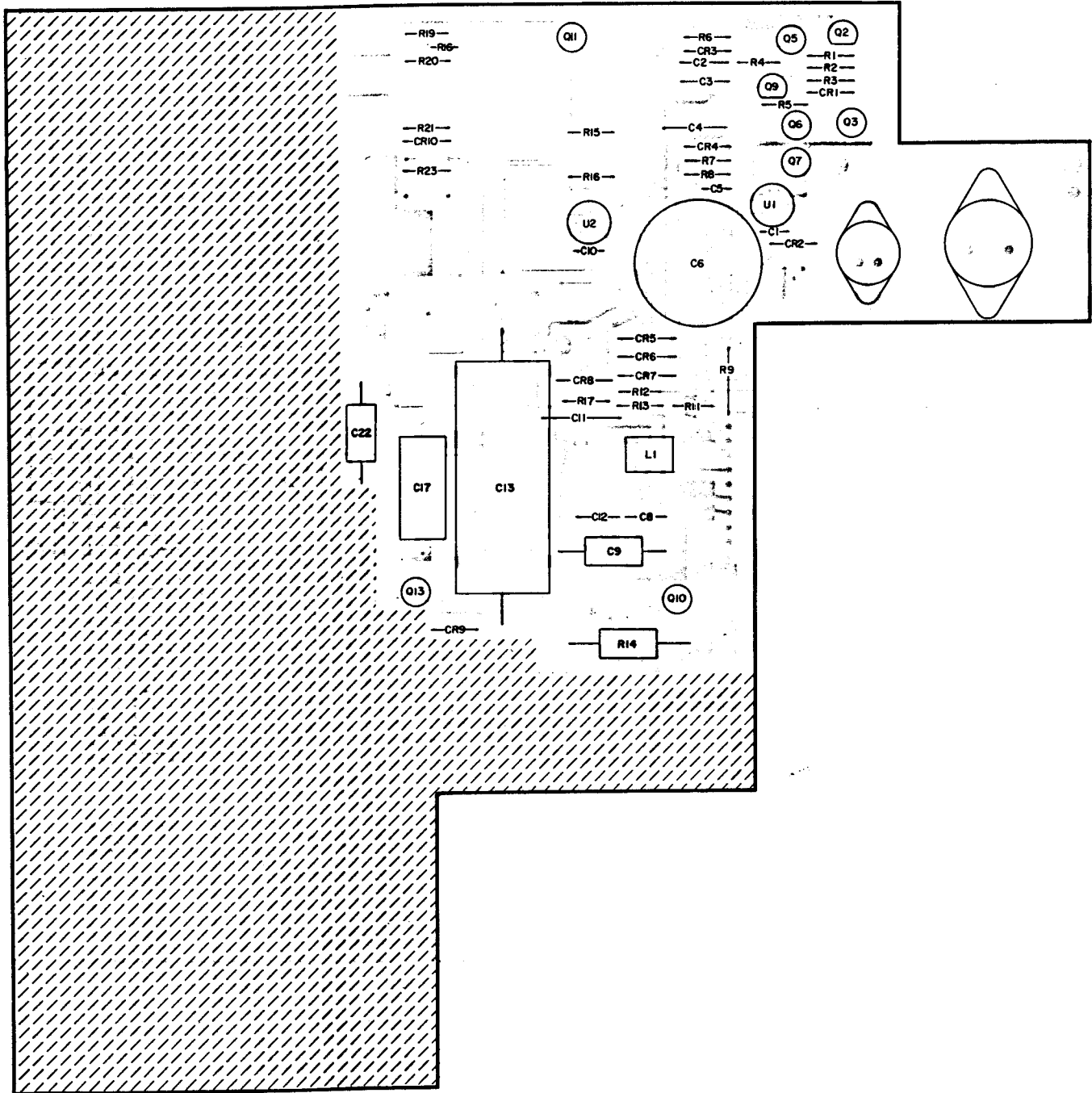

Component Designator: Power Supply

CAUTION

DO NOT OPERATE THE 9815A POWER SUPPLY (09815-66550) WITHOUT A LOAD. THE KEYBOARD ASSEMBLY MUST BE CONNECTED TO THE 66550 ASSEMBLY TO PROVIDE A LOAD WHEN SERVICING THE POWER SUPPLY.

P/O A50 POWER

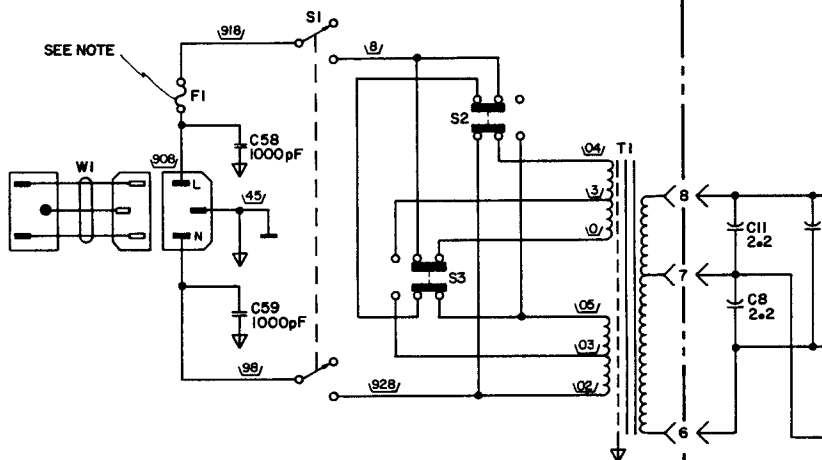

NOTE: F1 IS 1.5A FOR 100V AND 120V AC OPERATION.
F1 IS .75A FOR 220V AND 240V AC OPERATION.

* R11, R17 FACTORY SELECTED VALUE

R17 Padding List

0698-4473	8.06K	1%
0698-4472	7.68K	1%
0698-3518	7.32K	1%
0698-4470	6.98K	1%
0698-3484	6.65K	1%
0698-3228	6.49K	1%
0757-0290	6.19K	1%
0698-3515	5.92K	1%
0698-4445	5.76K	1%
0757-2200	5.62K	1%
0698-3382	5.49K	1%
0698-3258	5.36K	1%
0698-0063	5.23K	1%

09815-J-50743

CH18

3 TROUBLESHOOTING

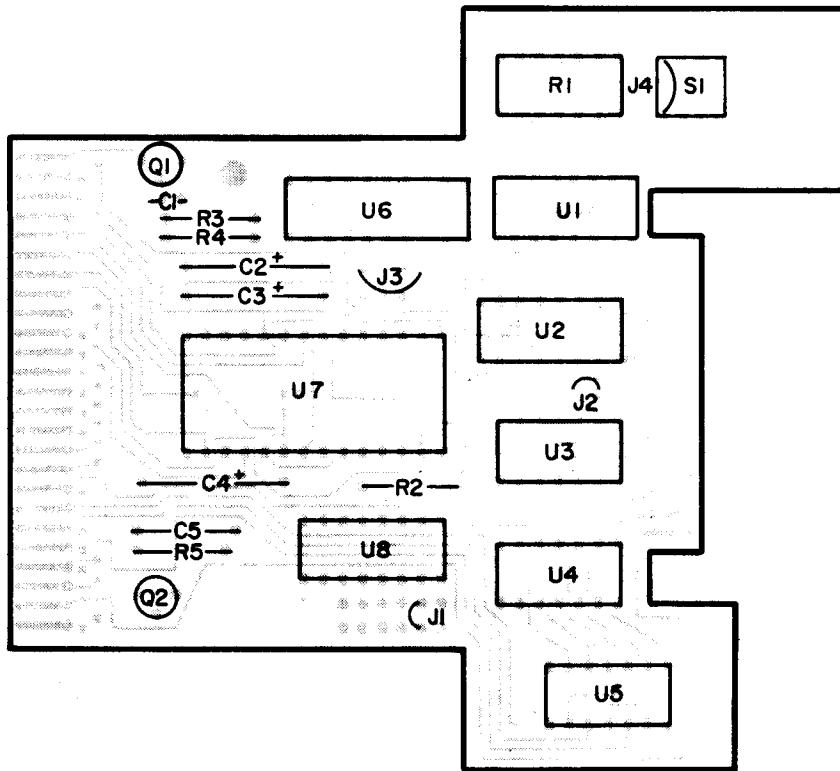

Component Locator: General I/O Assembly (98134-66503)

Figure 3-3. General I/O Interface Schematic Diagram

CHAPTER 4

REPLACEABLE PARTS

INTRODUCTION

This chapter lists the 9815A replaceable parts. The major cabinet parts are shown in Figure 4-1. Table 4-1 lists the calculator's assemblies and the electronic components shown on the schematics (Figure 3-2 and 3-3). Figure 4-2 is an exploded drawing of the printer with part numbers of the replaceable parts.

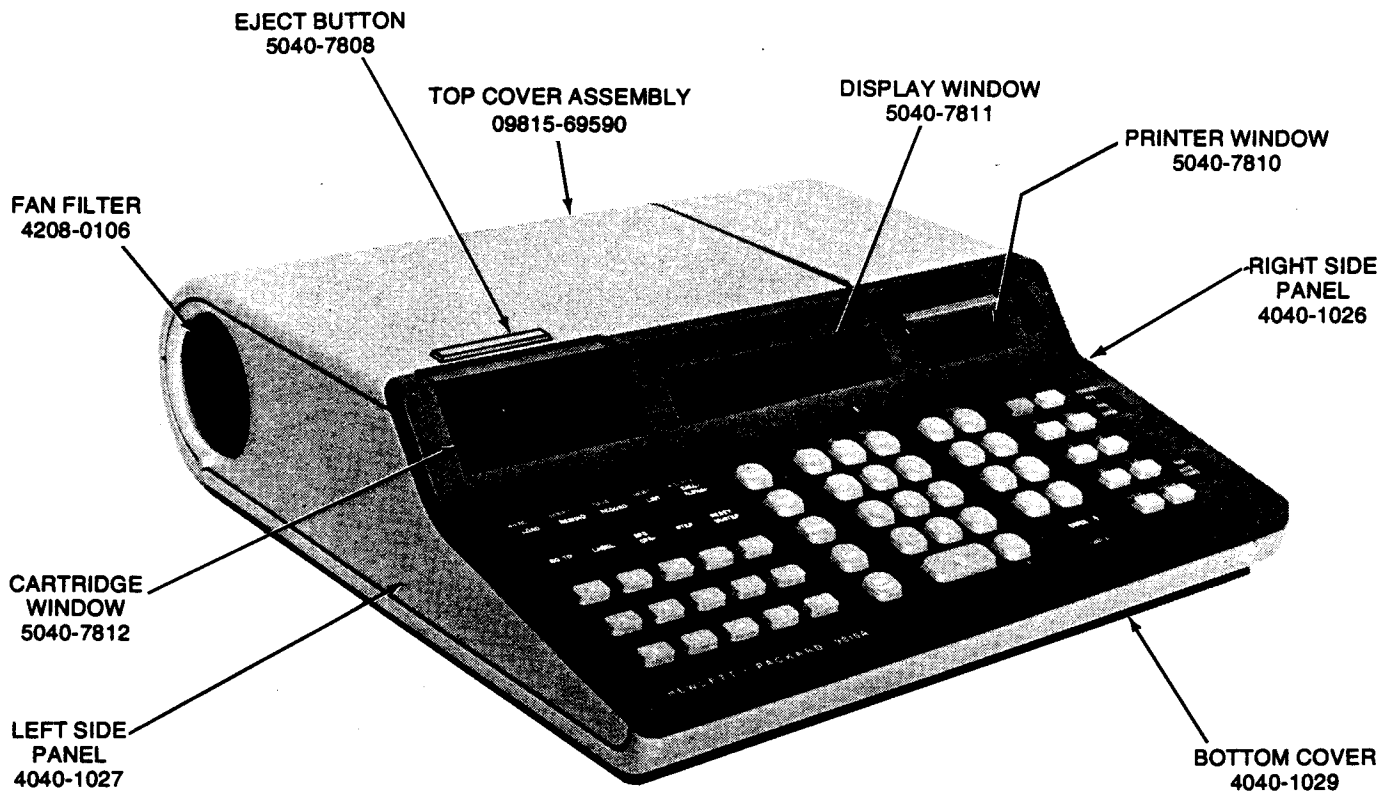

Figure 4-1. Calculator Cabinet Parts

4 REPLACEABLE PARTS

TABLE 4-1. REPLACEABLE PARTS

REFERENCE DESIGNATOR	PART NO.	TQ	DESCRIPTION	MFR.	MFR. PART NO.
	9220-0490	1	Dust Cover		
	09815-10001	1	User's Guide		
	09815-10004	1	Utility and Test Cartridge		
	09815-20602	1	Paper Spindle		
	09815-60101	1	Power Module Assembly		
A0	09815-66500	1	Peripheral Control Assembly		
A10	09815-66510	1	Processor Assembly		
A50	09815-66550	1	Power Supply Assembly		
	09815-67902	1	Cartridge Drive Assembly		
	09815-67930	1	Keyboard		
	09815-67940	1	Thermal Printer		
	09815-90000	1	Operating Manual		
	1251-2357	1	AC Power Connector		
C58,C59	0180-4183	2	C-F: 1000PF 5KV		
Q1	1853-0031	1	2N3789		
Q2	1854-0063	1	2N3055		
CR1	1901-0511	1	DIO: 1N3889		
	1970-0071	1	Gas Discharge Display		
	2110-0465	1	Fuse Cap		
	2110-0470	1	Fuse Holder		
S1	3101-2080	1	Power Switch		
S2,S3	3101-2042	2	Slide Switch		
	3140-0582	1	Fan Motor		
	3160-0277	1	Fan Blade		
	5040-7806	1	Butch Plate		
	8120-1378	1	AC Power Cable (US)		
	8500-1251	1	Magnetic Head Cleaner		
	9100-3466	1	Power Transformer		
	9162-0061	1	Data Cartridge (blank)		
	9270-0479	1	Thermal Printer Paper (6 rolls)		
A50	09815-66550	1	Power Supply Assembly (supply only)		
C1	0160-2964	2	C-F: .01UF 25V		
C2	0180-1701	1	C-F: 6.8UF 6V		
C3	0180-0210	1	C-F: 3.3UF 15V		
C4	0180-0228	1	C-F: 22UF 15V		
C5	0140-0234	1	C-F: 500PF 300V		
C6	0180-0677	1	C-F: 5800UF 40V		
C8	0160-0128	2	C-F: 2.2UF 25V		
C9	0160-4344	1	C-F: 6UF 75V		
C10	0160-2964	1	C-F: .01UF 25V		
C11	0160-0155	1	C-F: .0033 UF		
C12	0160-0128	1	C-F: 2.2UF 25V		
C13	0180-0687	1	C-F: 2100UF 40V		
C16	0160-3622	1	C-F: .1UF 100V		
C17	0180-2501	1	C-F: 680UF 24V		
C22	0180-1714	1	C-F: 330UF		
C23	0160-3558	1	C-F: .1UF		
CR1	1902-3188	2	DIO-BKDN 12.7V		
CR2	1901-0040	1	DIO-SI .05A 30V		
CR3	1902-3105	1	DIO-BKDN 5.62V		
CR4	1902-3188	1	DIO-BKDN 12.7V		
CR5-CR8	1901-0673	4	DIO-Power Rectifier		
CR9	1901-0026	1	DIO-SI .75A 400V		
CR10	1902-3094	1	DIO-BKDN 5.11V		
L1	9100-3487	1	Inductor-Filter		
L2	9100-3462	1	Inductor		
L3	9100-3473	1	RF Choke		
Q2	1854-0215	1	XSTR: 2N3904		
Q3	1853-0051	1	XSTR: 2N4037		
Q5	1854-0053	1	XSTR: 2N2218		
Q6	1853-0012	2	XSTR: 2N2904A		
Q7	1854-0039	1	XSTR: 2N3053		
Q9	1853-0016	1	XSTR: SPS 3320		
Q10	1853-0020	1	XSTR: SPS 3609		
Q11	1854-0071	1	XSTR:SPS 5103		

TABLE 4-1. REPLACEABLE PARTS (CONT)

REFERENCE DESIGNATOR	-hp- PART NO.	TQ	DESCRIPTION	MFR.	MFR. PART NO.
Q13	1853-0012		XSTR: 2N2904A		
R1	0683-2215	1	R-F: 220 5%		
R2	0698-7520	1	R-F: 3.01 5%		
R3	0683-5115	2	R-F: 510 5%		
R4	0683-1015	2	R-F: 100 5%		
R5	0683-1025	4	R-F: 1K 5%		
R6	0683-6815	1	R-F: 680 5%		
R7	0683-1515	1	R-F: 150 5%		
R8	0683-1025		R-F: 1K 5%		
R9	0811-2771	1	R-F: .18 3%		
R10	0683-2205	1	R-F: 22 5%		
R11	0698-4471	1	R-F: 7.15K 1%		
R12	0683-1035	2	R-F: 10K 5%		
R13	0683-1025		R-F: 1K 5%		
R14	0811-2490	1	R-F: .1 5W		
R15	0698-3259	1	R-F: 7.87K 1%		
R16	0683-1015		R-F: 100 5%		
R17	0698-3497	1	R-F: 6.04K 1% See Padding List - Figure 3-2		
R19	0683-1035		R-F: 10K 5%		
R20	0683-1025		R-F: 1K 5%		
R21	0683-5115		R-F: 510 5%		
R23	0757-0403	1	R-F: 121 1%		
U1	1820-0196	1	IC: U5R 7723393		
U2	1820-0321	1	IC: Digital Comparator		
A3	98134-66503	1	General I/O Assembly		
C1,C2	0180-1704	2	C-F: 47UF 6V		
C3	0180-0028	1	C-F: 22UF 15V		
C4	0160-0153	1	C-F: .001UF 200V		
C5	0160-4387	1	C-F: 47PF 100V		
P1	1258-0124	1	Plug, select code		
Q1	1853-0058	1	XSTR: si., PNP		
Q2	1854-0071	1	XSTR: Si., NPN		
R1	1810-0230	1	R-Network: 16-pin DIP		
R2,R4	0683-1025	2	R-F: 1K 5%		
R3	0683-6825	1	R-F: 6.8K 5%		
R5	0683-4825	1	R-F: 4.7K 5%		
S1	1200-0471	1	Socket: 8-pin DIP		
U1,U2	1820-1255	2	IC: DM8098N		
U3	1820-1144	1	IC: SN74LS02N		
U4,U5	1820-0471	2	IC: SN74273N		
U6	1820-1461	1	IC: SN74273N		
U7	1818-2627	1	IC: ROM		
U8	1820-1418	1	IC: SN74LS42J		
	98134-61603	1	Cable Assembly w/connector		
	1251-2171	1	Connector, 30 pin		
	5040-7781	1	Cover, Top		
	5040-7782	1	Cover, Bottom		
	98134-90000	1	Operating Manual		
	98134-90010	1	Reference Card		

4 REPLACEABLE PARTS

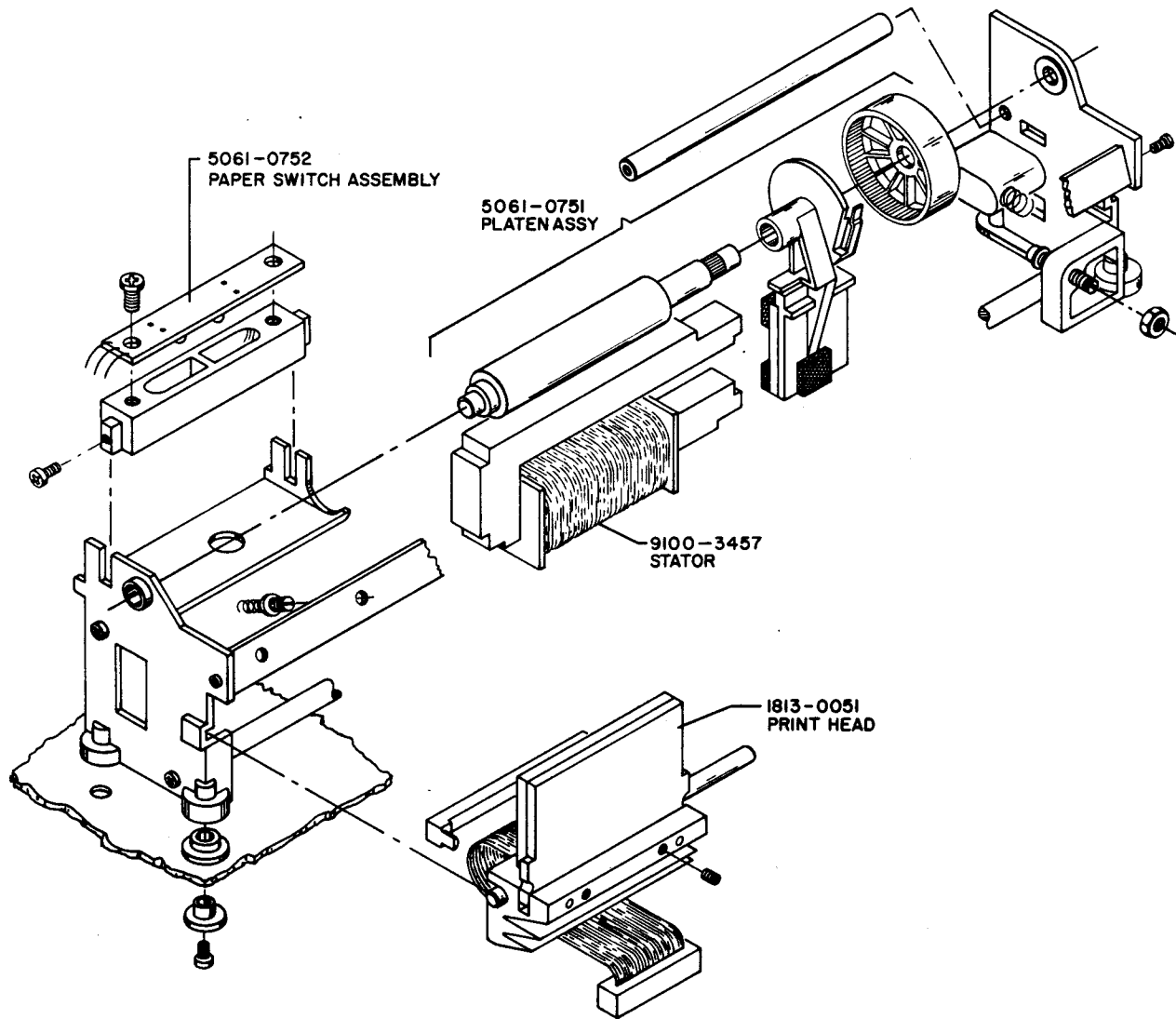
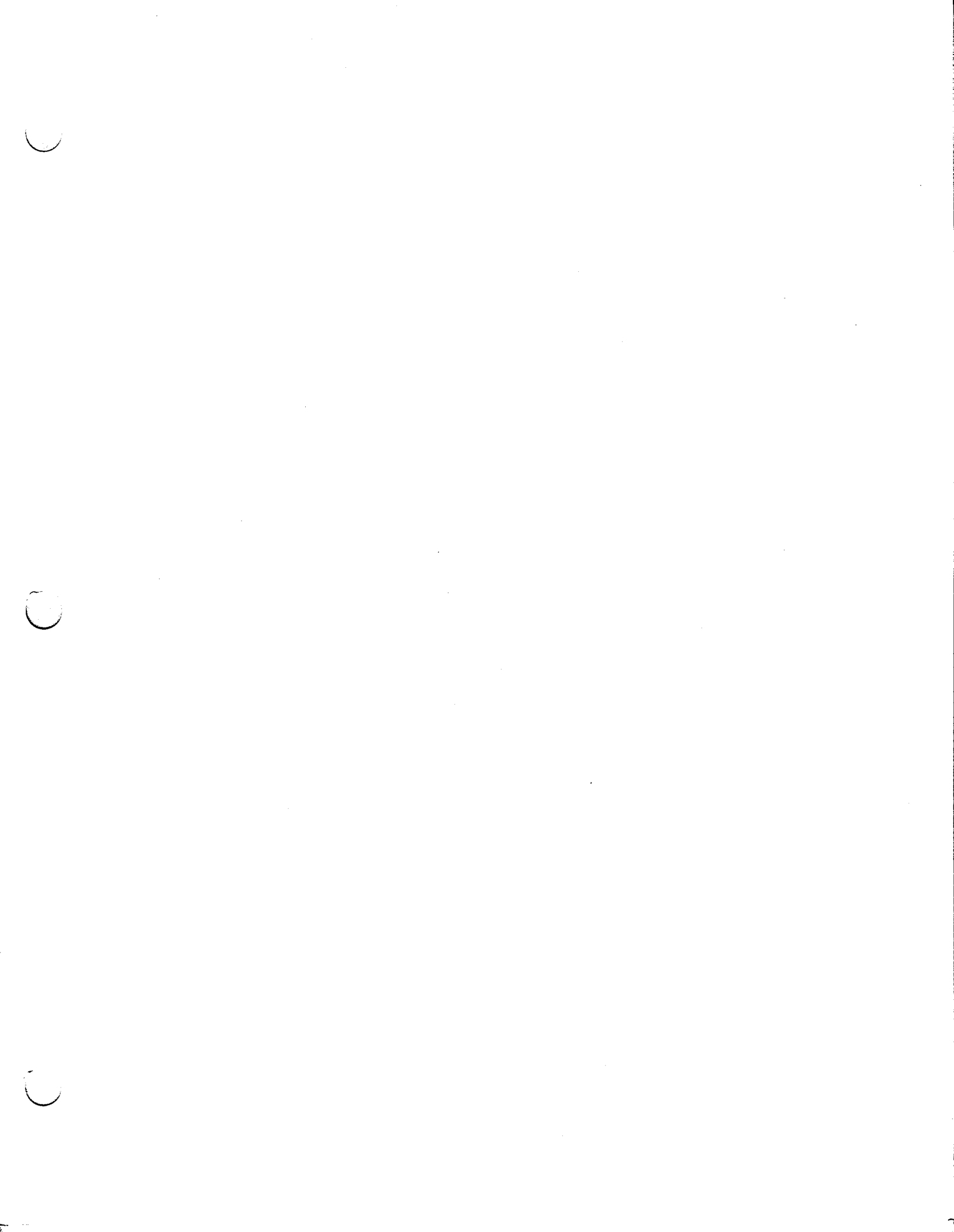

Figure 4-2. Printer Parts



PART NO. 09815-90030
March 2, 1976

PRINTED IN U.S.A