

**9805A
CALCULATOR**

SERVICE MANUAL
-hp- Part No. 09805-90030



HEWLETT-PACKARD CALCULATOR PRODUCTS DIVISION
P.O. Box 301, Loveland, Colorado 80537, Tel. (303) 667-5000



TABLE OF CONTENTS

CHAPTERS

CHAPTER 1: INTRODUCTION	
PURPOSE OF THIS MANUAL	1-1
SERVICE CONCEPT	1-1
THE CALCULATOR SERVICE REPAIR KIT	1-1
CHAPTER 2: INSTALLATION	
POWER REQUIREMENTS	2-1
SETTING THE VOLTAGE SELECTOR CARD	2-1
PRINTER PAPER	2-2
MODEL 5 OPTIONS	2-2
General Information	2-2
Keyblocks	2-3
PROM Blocks	2-4
Interface Cards	2-4
Display	2-4
Optional Data Registers	2-4
CHAPTER 3: INSTRUMENT MAINTENANCE	
GENERAL INFORMATION	3-1
PRINTER MAINTENANCE	3-1
CHAPTER 4: ASSEMBLY REPLACEMENT	
MODEL 5 ASSEMBLY ACCESS	4-1
Keyblocks and PROMs	4-1
The Keyboard, Display, Data Registers, and Interface Assemblies	4-3
Interface Cables	4-3
LINE ON/OFF Switch	4-3
Printer	4-3
Mother Board Replacement	4-3
INSTALLATION OF MODEL 5 ASSEMBLIES	4-4
CHAPTER 5: TROUBLESHOOTING	
REPAIRING THE MODEL 5	5-1
Initial Checks	5-1
Isolating the Problem	5-1
USING THE SYSTEM TEST PROM	5-1
Instructions for Exerciser 20	5-3
Instructions for Exerciser 30	5-3
Instructions for Exerciser 40	5-3
STATISTICS KEYBLOCK CHECKOUT PROCEDURE	5-8
Setting Up the 9862A Plotter	5-8
One Variable Checkout Procedure	5-8
Two Variable Checkout Procedure	5-11
CHAPTER 6: REPLACEABLE PARTS	
INTRODUCTION	6-1

TABLES

Line Voltage/Fuse Selection	2-1
Model 5 Options (For Service Use Only)	2-3
Equipment Required for P.M.'s	3-1
Model 5 Failure Symptoms	5-16
System Test PROM Symptoms	5-17
Replaceable Parts Lists	6-0

FIGURES

The Model 5 Power Module	2-1
Installing Printer Paper	2-2
The Basic Model 5 Assemblies	2-3
The Tear Bar and Print-Drum Cover	3-1
The 6" Strip of Paper Inserted During Cleaning	3-2
The Various Access Screws on the Bottom of the Calculator	4-1
The Model 5 Assemblies	4-2
Results from Exerciser 40	5-4
Results from STAT Keyblock Checkout Procedure	5-15
Keycap Part Numbers	6-1
Primary Power Schematic	6-1



Chapter 1

INTRODUCTION

This manual is intended for use by hp- service representatives and only provides the information required to enable the repair of a 9805A (Model 5) Calculator at the customer's location. All information contained herein is presented assuming that you are familiar with operating the Model 5.

PURPOSE OF THIS MANUAL

Information describing the service concept is provided in your most recent CPD Inter-office Service Memo (beginning with the March 1973 issue) and will be updated in future service memos. Copies of the most recent Model 5 service information should be inserted into this manual.

SERVICE CONCEPT

The Model 5 Service Kit (11390A)

The 11390A Service Kit contains a complete Model 5 Calculator. The March 1973 Inter-office Service Memo provides a listing of the Model 5 electronic assemblies that are in the 11390A Service Kit. Replacement or additional kits may be ordered from Calculator Products Division (CPD), Loveland or GmbH. Service kit replacement parts should be ordered from either CSC or PCE, whichever is appropriate.

THE CALCULATOR SERVICE REPAIR KIT

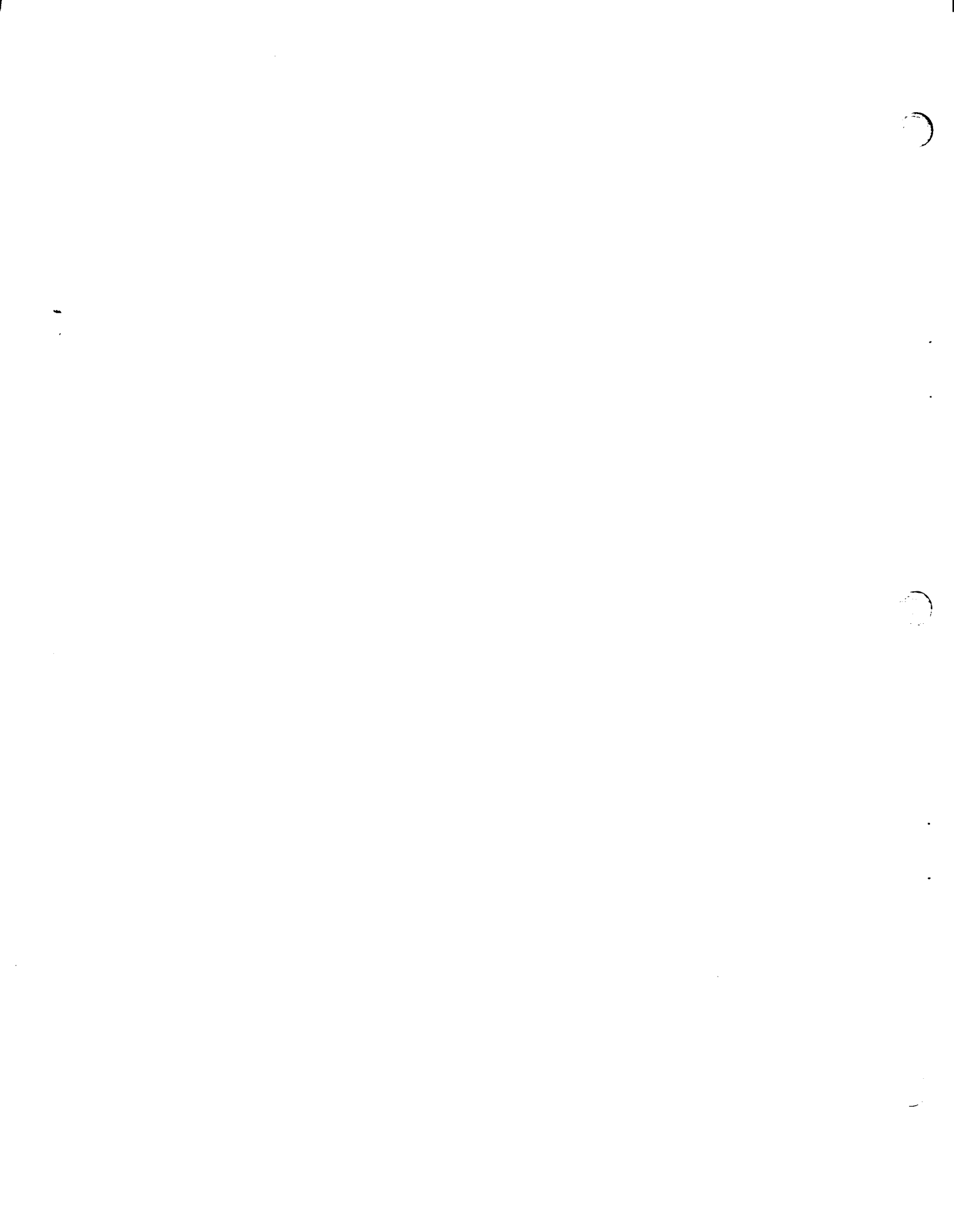

Chapter 2

INSTALLATION

POWER REQUIREMENTS

CAUTION

INSTRUMENT DAMAGE MAY RESULT IF AC POWER IS APPLIED TO THE INSTRUMENT WITHOUT PROPER INSTALLATION OF THE VOLTAGE SELECTOR CARD AND THE CORRECT FUSE.

The Model 5 Calculator will operate on a line voltage of either 120V ac or 240V ac. Input power tolerances (+8, -16%) permit operation within the ranges of 101V to 130V ac or 202V to 259V ac. The line frequency must be within the range of 48 to 66 Hz (inclusive).

NOTE

The voltage selector card, located inside the power module, is designed to enable the selection of two additional line voltages - 100V or 220V. Because of the input power tolerances, these two positions are not connected in the power module.

SETTING THE VOLTAGE SELECTOR CARD

The voltage selector card can be installed by performing the following procedure (refer to Figure 2-1):

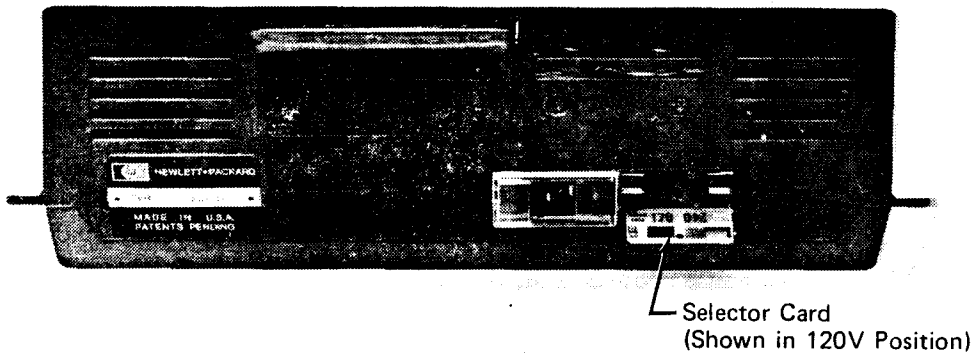

Figure 2-1. The Model 5 Power Module

1. Slide the clear plastic window on the power module to the left (over the power receptacle).
2. Pull the FUSE PULL lever out until it is against the power module and remove the fuse - if installed.
3. If the selector card is installed, it may be removed by using a sharp-pointed object (e.g., a ball-point pen) to pry the card out of the module.
4. Install the card into the module. The proper voltage selection is made when the number for the selected voltage is visible when the card is installed.
5. Return the FUSE PULL lever to its original position.
6. Install the appropriate fuse (see Table 2-1) into the fuse clip and slide the plastic window to the right.

Table 2-1. Line Voltage/Fuse Selection

LINE VOLTAGE	SETTING	FUSE	-hp- PART NUMBER
101V - 130V ac	120V	.5 amp NB	2110-0012
202V - 259V ac	240V	.25 amp NB	2110-0004

PRINTER PAPER
CAUTION

TO AVOID EXCESSIVE WEAR ON THE PRINTER'S PRINT DRUM, ALWAYS PRESS **PRT OFF** BEFORE REMOVING OR INSTALLING PAPER.

The following procedure should be used when replacing printer paper (see Figure 2-2):

1. Insert the metal shaft through the center of the roll of paper.*
2. Lift the printer cover up and place the metal shaft in the guides such that the paper will unwind from the bottom.
3. Pull about four inches of paper off the roll and fold the leading edge back about one inch.
4. Push the paper straight down into the slot just forward of the  arrow, while at the same time pressing the **PAPER** key. Ensure that the paper passes through the guide and behind the cutting edge.
5. Press **PAPER** a few times to verify that the paper is advancing properly, then press **PRT OFF** and perform the printer checkout procedure in Chapter 5.

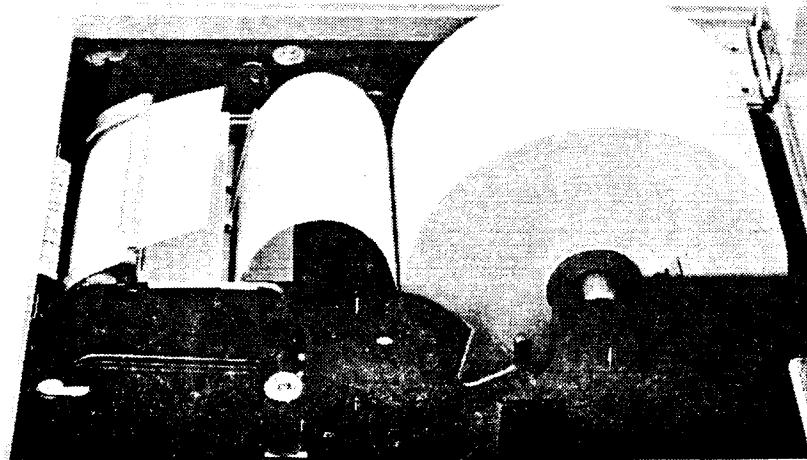

Figure 2-2. Installing Printer Paper

MODEL 5 OPTIONS
General Information

The Model 5 Calculator is intended to be a system which would be ordered by a customer to satisfy his specific requirements. For this reason, it is expected that a customer would usually have no reason to add to his system after the original purchase. However, since a few customers may wish to change their system, this presentation provides the information required for the field installation of Model 5 Options which are available at the time of this printing. Refer to the most recent IOSM for future options. Keyblocks cannot be ordered by the customer. Instead, he must order a complete accessory kit which contains all of the assemblies necessary to redefine his system. The accessory kits may contain a keyblock, a PROM, a peripheral and an interface, or any combination of those three assemblies.

*Any standard 2¼" wide adding machine paper may be used.

Table 2-2. Model 5 Options (For Service Use Only)

DESCRIPTION	ACCESSORY NO.	OPTION NO.
Plotter Interface	11357A	357
*100 Data Storage Registers	11365A	365
*30	11366A	366
Display	11367A	367
Statistics Keyblock	11331A	331
STAT PROM BLOCK	11376A	376

*Opt.365 and 366 are mutually exclusive.

Keyblocks

A Model 5 Keyblock is a block of keys which enable specific operations to be performed. Keyblocks contain their own Read Only Memory and plug into the basket in the lower left hand corner of the keyboard (see Figure 2-3).

Some keyblock keys may require the installation of other devices (e.g., PROMs or peripherals) to operate correctly.

The keyblocks (or cover plate) can be removed by using the access hole in the bottom of the calculator to push the keyblock out of the basket.

NOTE

Keyblocks may use keys which define a specific customer's routine; thus, the keyblock will have a unique set of keytops. The basic keyblock may be identified by the label on the bottom of the keyblock.

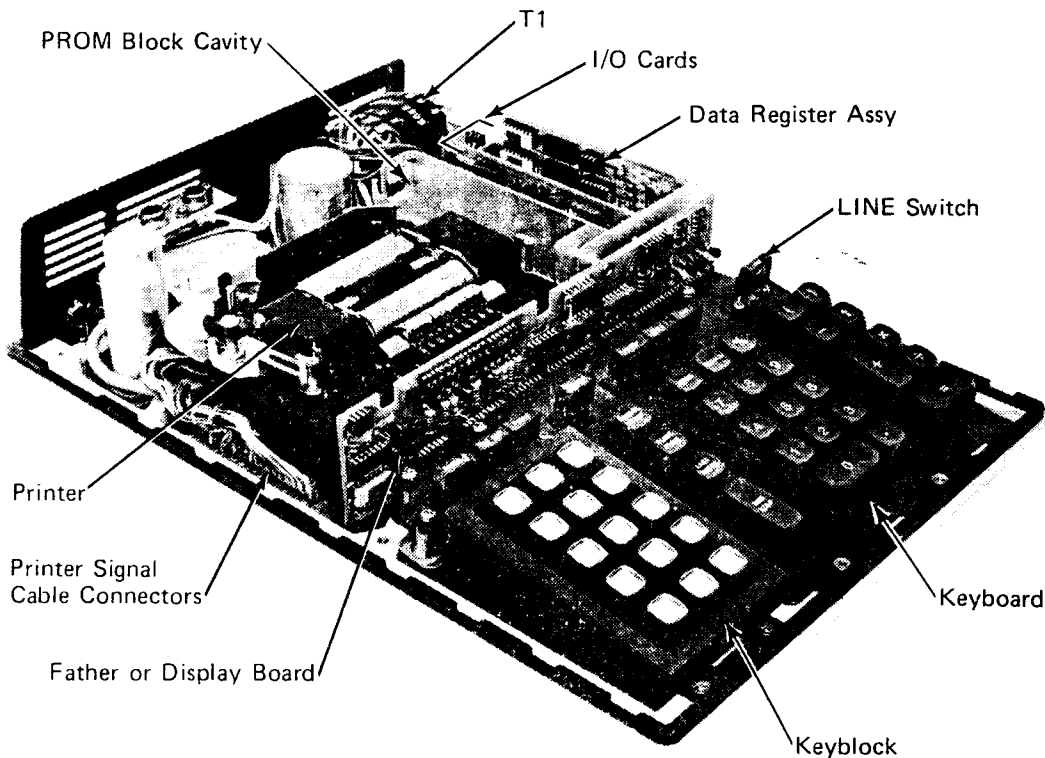



Figure 2-3. The Basic Model 5 Assemblies

MODEL 5 OPTIONS

(continued)

PROM Blocks

Programmable Read-Only Memories are devices which are unique to the Model 5. Basically, they function exactly the same as the traditional 9800-series ROM Blocks except that each PROM can be specially 'programmed' at the factory to accomplish specific, predetermined tasks (e.g., banking, finance, or car dealer routines).

Also, since the PROM may define the function of some of the keyblock keys, it may appear that the keyblock is unique to a specific system. This is not true, as the keyblock must be one of several available keyblocks. All PROMs require the use of a keyblock, but their operation may also be associated with the use of the  key.

A single slot is located beneath the printer cover for PROM Block installation (see Figure 2-3).

Interface Cards

Figure 2-3 shows a Model 5 with the top cover removed and indicates the interface card PC slots. Up to 3 cards can be installed at one time. We recommend that the cards be installed with the first card in the left-most slot, with the associated I/O connector in the bottom backpanel position. Future installations can be accomplished more easily with the card and connector installed in those locations.

CAUTION

CARE MUST BE TAKEN TO ENSURE THAT THE I/O CABLE IS NOT DAMAGED DURING ITS INSTALLATION.

Display (Option 367)

A display can be installed in the Model 5 by replacing the A40(09805-66540) Father board with an A41 Display assembly (09805-66541) (see Figure 2-3). Exchange credit for the A40 assembly will not be allowed.

Optional Data Registers (Options 365 or 366)

The installation of additional data registers may be required by either a data register option (Options 365 or 366) or an accessory kit option. If no data registers have been previously installed, either the 30(09805-11366) or the 100(09805-11365) data register assembly may be installed in the single slot to the right of the I/O cards (see Figure 2-3). If the unit contains the 30 data register assembly, the 100 data register (09805-11365) assembly (only) can be installed by removing the previously installed assembly and replacing it with the Option 365 assembly.

Chapter 3

INSTRUMENT MAINTENANCE

The calculator can be cleaned by using a soft, moist cloth. The use of abrasive or harsh detergents should be avoided, and moisture should not be allowed to penetrate into the calculator. Avoid scratching the display window.

GENERAL INFORMATION

The printer requires that some periodic maintenance be performed to avoid printer failures. The manufacturer recommends that these procedures be performed after 10 rolls of paper or every 3 months, whichever occurs first.

PRINTER MAINTENANCE

Table 3-1. Equipment Required for P.M.'s

DESCRIPTION
*stiff bristle brush
flexible bristle brush (-hp- P/N 8520-0015)
soft cloth

1. Advance the paper about 6". Tear off and save the 6" strip of printer paper.
2. Lift the printer cover up and remove the paper tear bar and print-drum cover (see Figure 3-1) by pulling each device up until it releases.

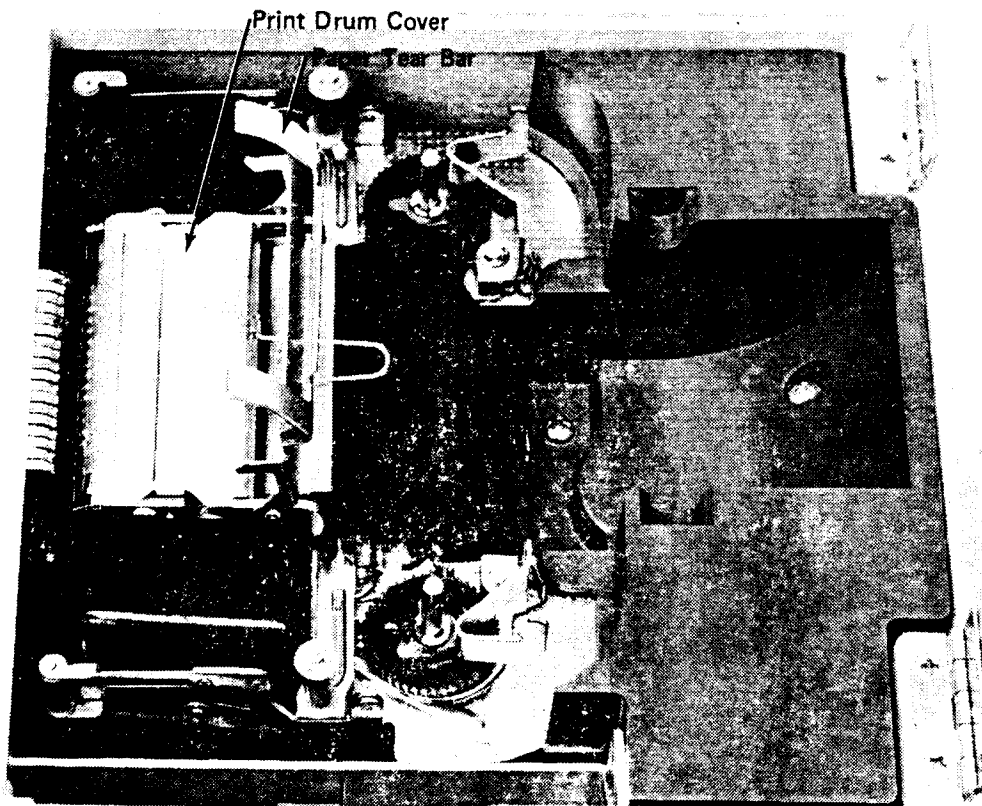

Figure 3-1. The Tear Bar and Print-Drum Cover

*One of the brushes in the service kit can be trimmed to a ¼" length for this purpose, or a standard typewriter brush can be used.

**PRINTER
MAINTENANCE**
(continued)

3. Remove the ribbon and inspect it for wear. If the ribbon has begun to fragment or fray, the ribbon should be replaced to prevent ribbon particles from jamming the printer mechanisms.
4. Remove the roll of printer paper.
5. Slide the 6" strip of printer paper (from step 1) around the print drum (see Figure 3-2).
6. Use a stiff brush to clean each character on the print drum.
7. When the drum is clean, fold the front end of the printer paper inward about 1" from the end and firmly crease the fold. Then, pull the paper out by the back end until it's clear of the drum. Care should be taken to ensure that a minimum of the paper's contents are spilled when the paper is removed.
8. Use a flexible brush to clean as much of the paper chips and ribbon particles from the printer as possible — especially in the area of the print drum.
9. Wipe the remainder of the printer surface areas clean with a soft cloth.

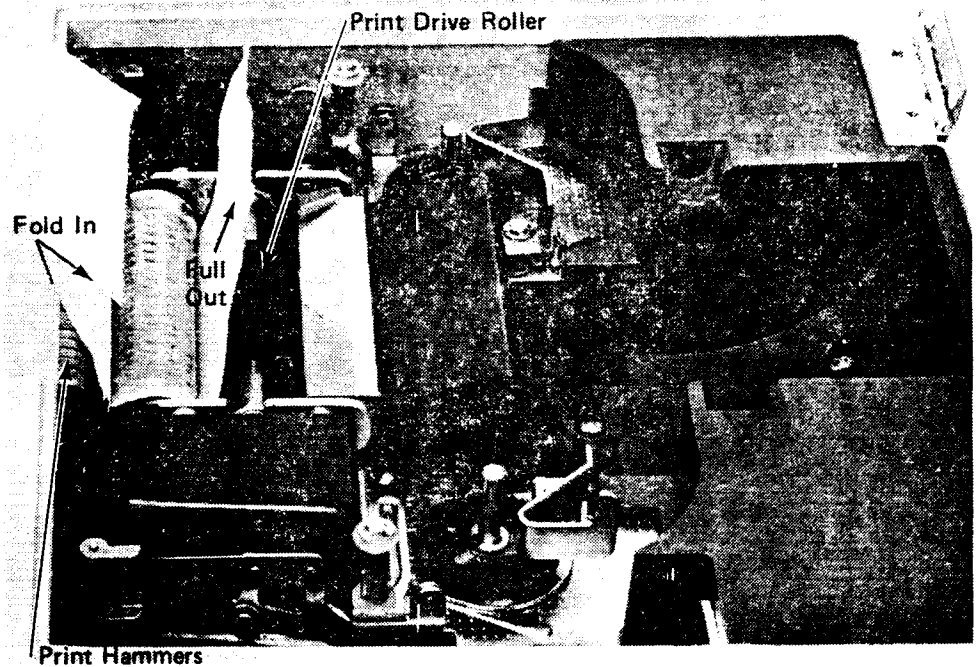

Figure 3-2. The 6" Strip of Paper Inserted During Cleaning

Chapter 4

ASSEMBLY REPLACEMENT

This presentation provides the information for accessing each of the Model 5 assemblies.

MODEL 5 ASSEMBLY ACCESS

CAUTION

ALL AC POWER TO THE CALCULATOR AND ALL CALCULATOR PERIPHERALS MUST BE DISCONNECTED BEFORE ANY ASSEMBLY IS INSTALLED OR REMOVED.

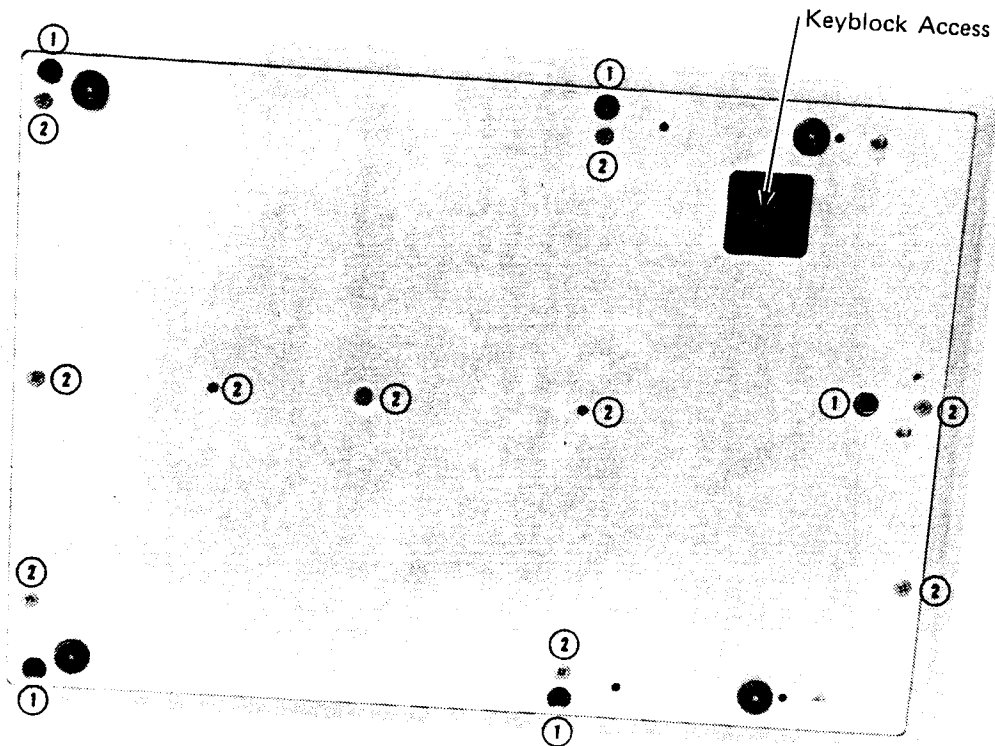

Remove ① for Top Cover Removal
Remove ② for Bottom Cover Removal

Figure 4-1. The Various Access Screws on the Bottom of the Calculator.

Keyblocks and PROMs

The keyblock can be removed by pressing up on the bottom of the keyblock through the access hole in the bottom of the calculator.

The PROM (see 'PROMs' in Chapter 2) can be removed by lifting the printer flap up and lifting the PROM out of the printer.

ASSEMBLY REPLACEMENT

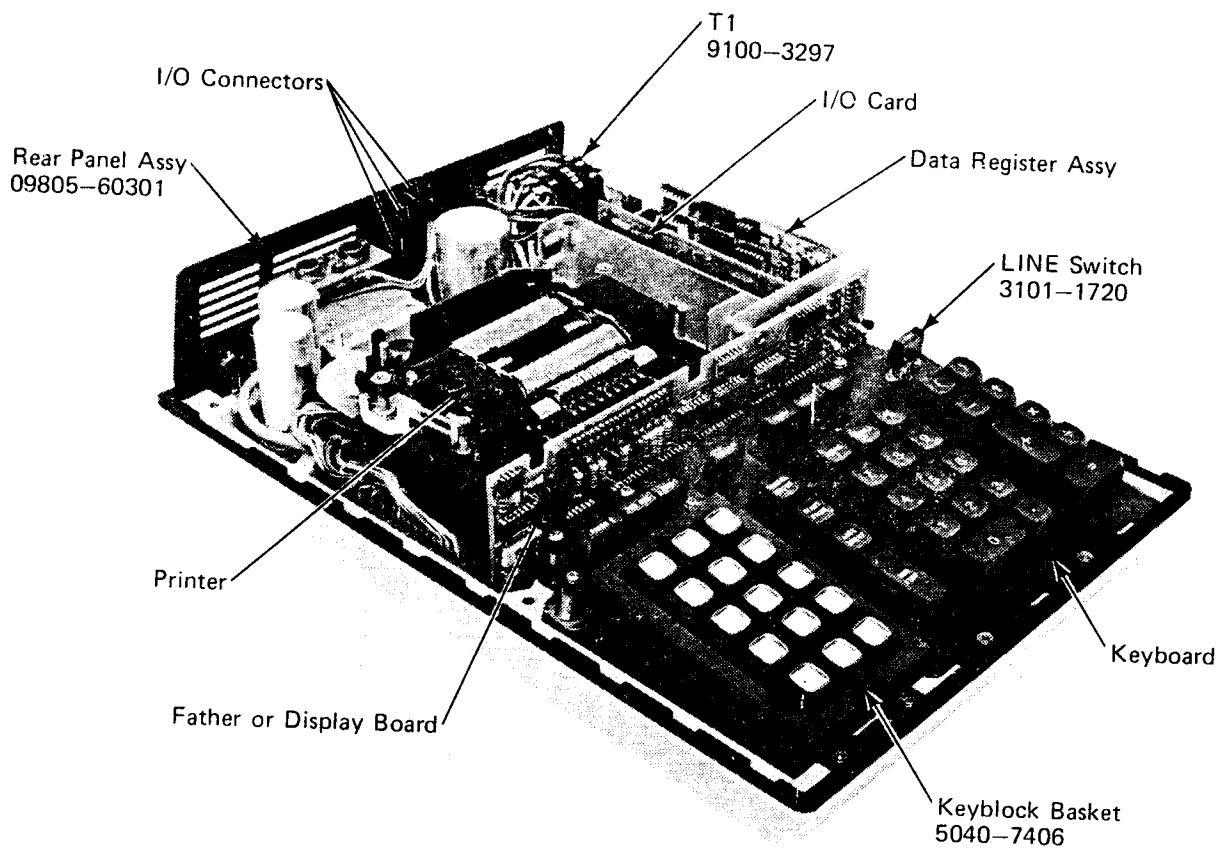

Figure 4-2. The Model 5 Assemblies

The Keyboard, Display, Data Registers, and Interface Assemblies

Each of these assemblies require that the printer paper and top cover be removed to enable their access. Figure 4-1 shows the five screws which secure the top cover to the chassis. Once the top cover has been removed, most of these assemblies can be removed without disconnecting any other assembly. The LINE ON/OFF switch must be removed from the keyboard to enable keyboard removal. The keyboard signal cable must be carefully removed from the left IC socket. When installed, the cable must be on the right side with the brown wire on the bottom.

CAUTION

THE KEYBOARD INTERCONNECTING CABLE CAN BE EASILY DAMAGED DURING KEYBOARD INSTALLATION OR REMOVAL.

Interface Cables

To remove an I/O cable, first remove the printer paper, top cover, and the associated interface card. Then, remove the two associated screws in the back panel and carefully lift the cable out of the calculator.

LINE ON/OFF Switch

If the LINE ON/OFF switch is defective, it should be removed from the keyboard and, together with the cable, replaced. A soldering iron is necessary to unsolder the cable from pins B, H, L and M of the power module (see the 'Primary Power Wiring Diagram' in the back of this manual).

Printer

The printer paper, top cover, bottom cover, paper well, and ribbon must all be removed before the printer can be removed. Then, disconnect the printer signal cable and remove the four slotted-type screws which secure the printer to the mother board (see Figure 4-2).

CAUTION

THE PRINTER MUST BE HANDLED AND PACKAGED CAREFULLY TO AVOID ANY UNNECESSARY DAMAGE TO ANY PRINTER PARTS.

Mother Board Replacement

The following assemblies must be removed (in order) from the calculator before the mother board can be removed:

- | | | |
|--------------------|----------------------------------|-----------------------|
| 1. Paper | 5. Top and bottom covers | 9. Keyblock basket |
| 2. PROM ass'y | 6. Display or Father board | 10. Paperwell |
| 3. Keyblock | 7. All installed interface cards | 11. Printer |
| 4. All peripherals | 8. Keyboard | 12. Interface chassis |

Once all of these assemblies have been removed (in order), the mother board can be disconnected by removing the screws which secure the mother board to the chassis and lifting the board off the mainframe.

CAUTION

THE MOTHER BOARD FITS INTO A SLOT WHICH IS MOLDED INTO THE FRONT OF THE CHASSIS. WHEN THE MOTHER BOARD IS BEING INSTALLED, CARE MUST BE TAKEN TO ENSURE THAT THE MOTHER BOARD IS PROPERLY POSITIONED (FRONT FIRST) OVER THE CENTER GUIDE AND UNDER THE TWO SIDE GUIDES IN THE FRONT OF THE CHASSIS. ONCE THE MOTHER BOARD IS SECURED IN PLACE, RETURN THE PREVIOUSLY REMOVED PARTS (IN THE REVERSED ORDER SHOWN ABOVE) TO THE CALCULATOR. BE SURE THAT THE KEYBLOCK BASKET IS PROPERLY POSITIONED OVER THE KEYBLOCK CONNECTOR ON THE MOTHER BOARD.

**INSTALLATION
OF MODEL 5
ASSEMBLIES**

Each of the assemblies should be returned to the calculator by reversing the procedure given for its removal.

Chapter 5

TROUBLESHOOTING

REPAIRING THE MODEL 5

Initial Checks

Before an attempt is made to repair the Model 5, a few quick checks should be made to ensure that a failure has actually occurred:

1. Verify the customer's complaint and ensure that the complaint is not due to some type of user error.
2. Check for an improperly installed system; especially verify that any installed PROM is being used with the correct type of keyblock.
3. If the calculator is completely inoperative, check and, if necessary, replace the line fuse. If the line fuse blows again, refer to Table 5-1 for repairing the instrument.
4. Disconnect any installed peripherals and verify that a peripheral is not the source of the trouble.
5. Use the special System Test PROM (-hp- P/N 9805-90031) to check calculator -- see 'Using the System Test PROM' on the following pages.

NOTE

The Power Supply Test Assembly (5060-9199) should be installed in one of the I/O slots (component side to the left) and each of the power supplies tested before performing any of the following procedures. Each power supply output should be within the tolerances given below.

Supply	Tolerance
+5Vdc	+4.75 to +5.25
+6Vdc	+5.6 to +6.6
-12Vdc	-11.2 to -13.2
+15Vdc	+14.1 to +16.3

Isolating the Problem

Once the initial checks have been made and are found to be satisfactory, Table 5-1 should assist you in finding the defective assembly.

USING THE SYSTEM TEST PROM

The Model 5 'System Test PROM' is programmed to test either the basic calculator, the data storage registers, the printer, or the plotter I/O card (which includes a cursory test of the 9862A Plotter). To use the PROM, perform the following procedure:

1. Switch the calculator OFF, and install the PROM. Then, remove any installed keyblock and peripheral (other than the plotter) and switch the system ON.

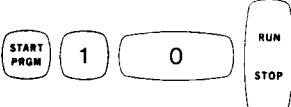
2. PRESS: 

Exerciser 10 is selected to test the basic machine. This key sequence can be used for other exercisers by replacing the 10 with the appropriate exerciser number (20, 30, or 40).

3. When 3.14 is printed and displayed, exerciser 10 is complete and the resulting printout should be the same as the exerciser 10 listing provided on the following page.
4. If any exerciser fails to run properly, see Table 5-2.
5. Exerciser 20 (Data Storage Register), 30 (Printer), or 40 (Plotter) may be run by performing the instructions given below, then using the key sequence from step 2 (with the appropriate exerciser number) to run the test.

USING THE
SYSTEM
TEST PROM
(continued)

NOTE
Exerciser 10 must be successfully completed before continuing to any other exerciser.

BASIC MACHINE PRINTOUT
Exerciser No. 10

```

                                CLEAR
                                CLEAR
1.023456789  00 #
.0000000000  00 #
1.0000000000  00 #
2.0000000000  00 #
3.0000000000  00 #
-4.0000000000  00 # ← Red
5.0000000000  00 #
6.0000000000  00 #
7.0000000000  00 #
COMMENT AT B+10%

                                CLEAR
                                4.00  #
                                100.00 #
                                101.00 #
                                101.00 #
                                102.00 #
                                102.00 #
                                103.00 #
                                103.00 #
                                104.00 #
                                104.00 #
                                105.00 #
                                105.00 #
                                106.00 #
                                106.00 #
                                107.00 #
                                107.00 #
                                108.00 #
                                108.00 #
                                109.00 #
                                110.00 #
                                210.00 #
                                310.00 #
                                1.00  #
                                .00  #
-                                1.00 # ← Red
                                2.00 #
                                3.14 #
```

Instructions for Exerciser 20

Run Exerciser 10, then PRESS:

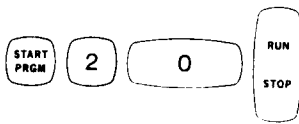

After 'DATACLEAR' is printed, input the number of registers which are installed in the calculator (30 or 100) and press RUN. Each of the nine checks begins with the printing of DATA and either 29 or 99 (the number of registers minus 1). Each of the 9 tests should result in a printout of the data in each register, separated into groups of 10 (i.e., either 3 or 10 groups of 10). Each individual check is complete when END is printed. The final (9th) printout is one decimal for each data register. The complete exerciser may take up to 15 minutes.

Instructions for Exerciser 30

Run Exerciser 10, then PRESS:

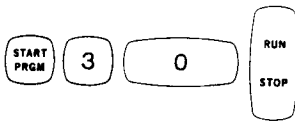

Exerciser 30 should result in the following printout.

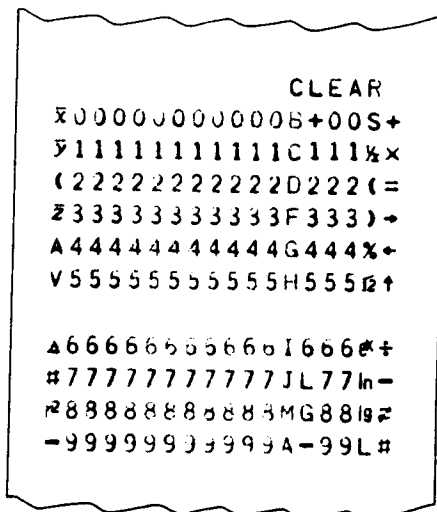

Instructions for Exerciser 40

Run Exerciser 10 before beginning Exerciser 40. The plotter exerciser completely checks the plotter I/O card, but is only a cursory check of the plotter. Before beginning the test, place a sheet of paper on the platen and set the two plotter limits 1 inch in from the edges of the

paper. Then, run the exerciser by pressing:

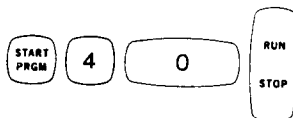

NOTE

If Exerciser 40 runs properly, but the customer's plotter routines fail, the 'Statistics Keyblock Checkout Procedure' should be performed.

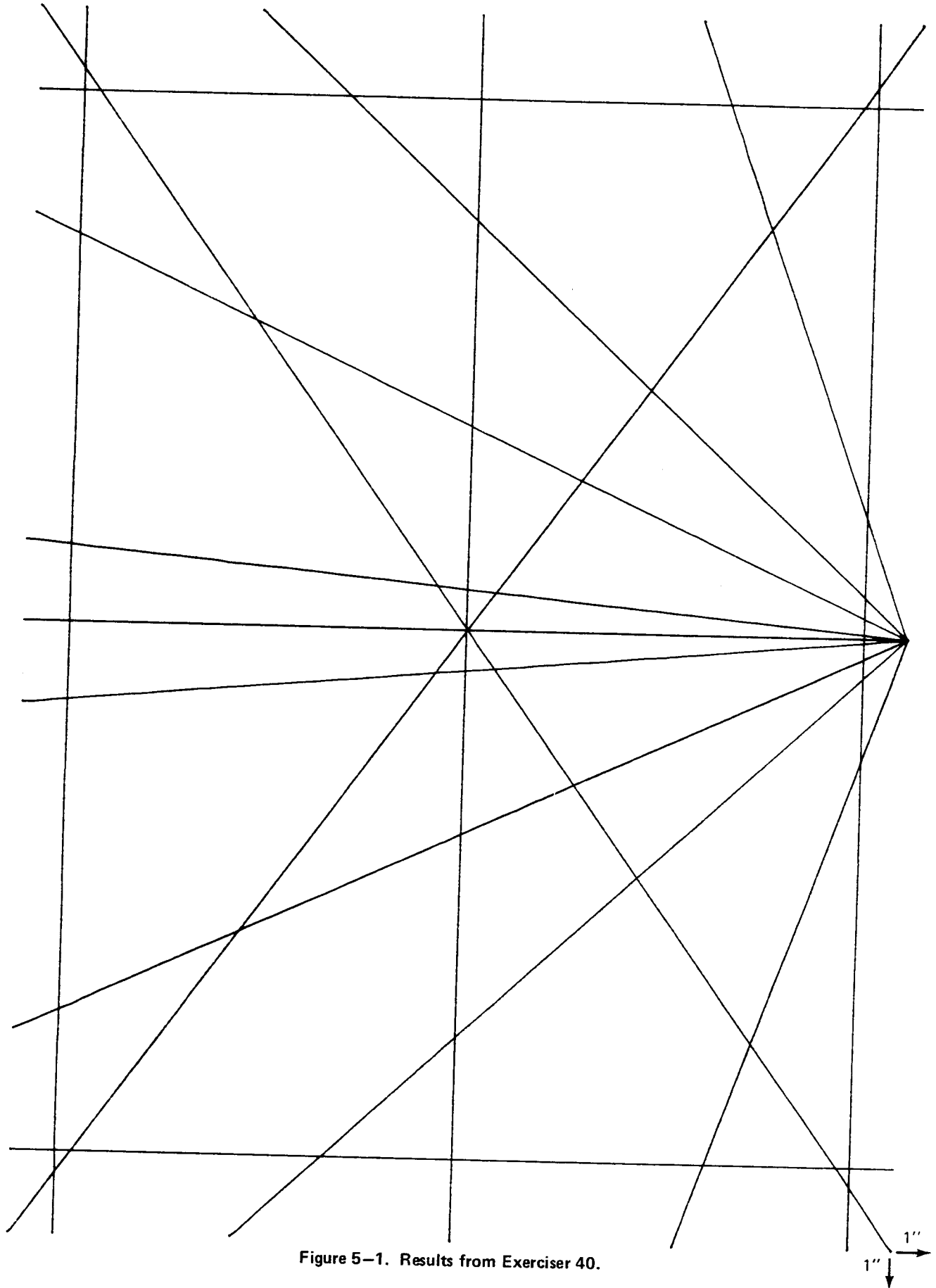

Figure 5-1. Results from Exerciser 40.

**STATISTICS KEYBLOCK
CHECKOUT
PROCEDURE**

NOTE
Exerciser 10 of the 'System Test PROM' must be successfully performed before this procedure is begun.

NOTE
This procedure should be used when you need to determine if a STAT keyblock is defective and a substitute keyblock is not available. If this procedure can successfully be performed and the customer's STAT Model 5 doesn't operate correctly, the PROM should be suspect. If this procedure cannot be performed correctly, the keyblock should be suspect. **DO NOT SKIP STEPS UNLESS INSTRUCTED TO DO SO.**

Setting Up the 9862A Plotter

Place a sheet of 8½" x 11" paper on the plotter platen and press the PAPER HOLD button down. Then, set the plotter graph limits approximately 1" in from each of the paper's edges (see arrows on Figure 5-2). Remove any installed PROM.

One Variable Checkout Procedure

NOTE
Part of the following procedures require plotter operations. If a plotter is not installed, perform only the specified steps. If any doubt exists as to correct plotter operation, perform Exerciser 40 of the 'System Test PROM'.

Remove any installed PROM, then ensure that the plotter (if installed) and calculator are properly connected and are switched ON. Then, press the following keys in the exact sequence given and compare the printout (and plot) with those shown. If an error is made during an entry, return to step 1.

STEP: PRESS: PRINTOUT: COMMENTS:

- 1. CLEAR
- 2. RND () 2
- 3. VAR # 1
- 4. OFFSET
WIDTH
- 5. 0 DATA
ENTRY
- 6. 1 DATA
ENTRY

(continue to step 14 of this procedure if a plotter is not installed.)

- 7. 0 STORE
- 8. 5 AXES 1

```

                CLEAR
V1            .....
                OF    =
                .00   #
                C E L=
                1.00   #
                .00   #
                RG1   =
                .00   #
                5.00   #
    
```

STEP:

PRESS:

PRINTOUT:

COMMENTS:

9.

(5) (AXES) (2)

```

RG2      =
  .00    #
 5.00    #
    
```

10.

(1) (STORE)

```

1.00    →
    
```

11.

(AXES) (3)

```

  T I    =
 1.00    #
 1.00    #
    
```

12.

(0) (STORE)

```

.00     →
    
```

13.

(AXES) (4)

```

  A I    =
  .00    #
  .00    #
    
```

} Plotter plots x and y axes before the Model 5 prints this.

14.

(1) (DATA ENTRY)

```

1.00    #
    
```

15.

(2) (DATA ENTRY) (2) (DATA ENTRY)

```

2.00    #
    
```

16.

(3) (DATA ENTRY) (3) (DATA ENTRY)

```

2.00    #
    
```

(3) (DATA ENTRY)

```

3.00    #
    
```

(3) (DATA ENTRY)

```

3.00    #
    
```

(4) (DATA ENTRY)

```

4.00    #
    
```

(4) (DATA ENTRY)

```

4.00    #
    
```

```

4.00    #
    
```

```

4.00    #
    
```

```

4.00    #
    
```

18.

(BASIC STAT)

```

  N      =
10.00   #
    
```

```

  x      =
  3.00   #
    
```

```

  Δ1     =
  1.05   #
    
```

**STATISTICS KEYBLOCK
CHECKOUT PROCEDURE**

(continued)

STEP:

PRESS:

PRINTOUT:

COMMENTS:

19.



After 'HISTOGRAM PRINTOUT' is complete, skip STEP 20 if a plotter is not installed.

20.



The plot should be identical to the 'FIRST PLOT' shown in Figure 5-2.

		HG	
1.00	#		
.00	#		
.00	#		
.00	#		
2.00	#		
1.00	#		
1.00	#		
10.00	#		
3.00	#		
2.00	#		
2.00	#		
20.00	#		
4.00	#		
3.00	#		
3.00	#		
30.00	#		
5.00	#		
4.00	#		
4.00	#		
40.00	#		
6.00	#		
5.00	#		
.00	#		
.00	#		
7.00	#		
6.00	#		
.00	#		
.00	#		
8.00	#		
7.00	#		
.00	#		
.00	#		
9.00	#		
8.00	#		
.00	#		
.00	#		
10.00	#		
9.00	#		
.00	#		
.00	#		

Two Variable Checkout Procedure

This procedure should be performed exactly the same as the single variable procedure. If a plotter is not installed, perform steps 1 and 2, then skip to step 11.

STEP: PRESS: PRINTOUT: COMMENTS:

- 1. [CLEAR]
- 2. [RND ()] (2)
- 3. [VAR #] (2)
- 4. (0) [STORE]
- 5. [6] [AXES] [1]
- 6. [6] [AXES] [2]
- 7. [1] [STORE]
- 8. [1] [AXES] [3]
- 9. (0) [STORE]
- 10. [AXES] [4]

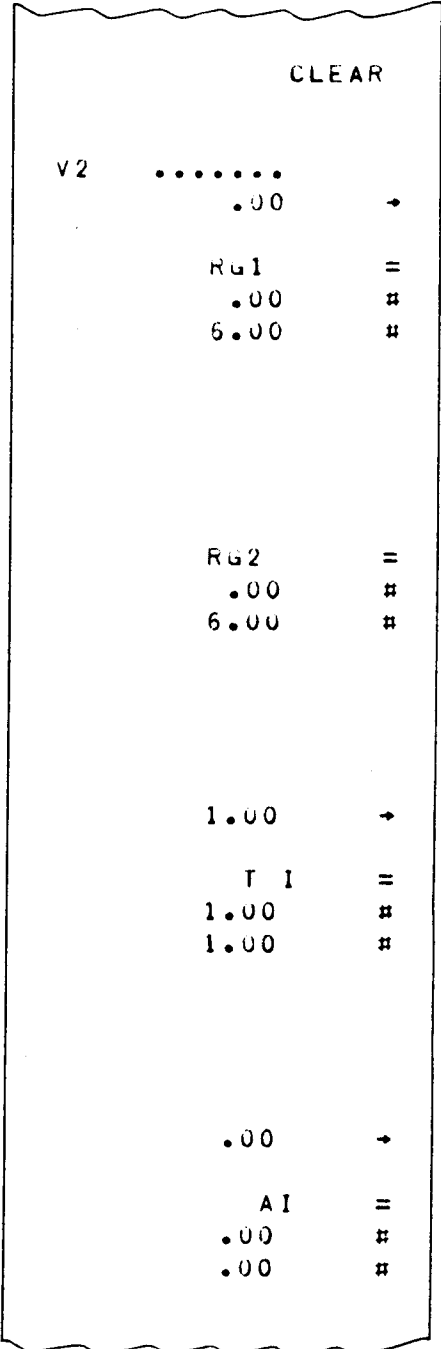

This portion of the procedure requires that a Plotter be installed.

Second x and y axes should be plotted over previous axes. New tic marks will be plotted.

**STATISTICS KEYBLOCK
CHECKOUT PROCEDURE**
(continued)

STEP:	PRESS:	PRINTOUT:	COMMENTS:
10.	CHAR # 2	CT 2	
	NOTE If a plotter is not installed, begin procedure here.	1.00 #	If plotter is not installed, begin procedure here.
		1.00 #	2nd 'DATA ENTRY' cause a \diamond character to be plotted at a specified point if a plotter is installed.
11.	1 DATA ENTRY	5.00 #	
12.	DATA ENTRY	2.00 #	
13.	5 DATA ENTRY	A =	LINEAR REGRESSION PRINTOUT
14.	DATA ENTRY	.75 #	
15.	DATA ENTRY	B =	
	LINEAR	.25 #	
		r ² =	
		1.00 #	
16.	3 . 5 EVAL	LE	For any given x(3.5) gives the value of y.
		3.50 #	
17.	PLOT	1.63 #	Pressing 'PLOT' causes the linear regression to be plotted as shown by 'SECOND PLOT' in Figure 5-2.
18.	CHAR # 3	CT 3	
19.	DELETE	D E L	
20.	5 DATA ENTRY	5.00 #	The character X plotted before this print-out occurs.
21.	5 DATA ENTRY	5.00 #	
22.	4 DATA ENTRY	4.00 #	The character \square plotted.
		2.00 #	
23.	2 DATA ENTRY	5.00 #	
24.	5 DATA ENTRY	1.00 #	
25.	1 DATA ENTRY	A =	PARABOLIC PRINTOUT
		3.67 #	
26.	PARA	B =	
		5.75 #	
		C =	
		1.08 #	
27.	PLOT	r ² =	Parabolic curve plotted as shown in THIRD PLOT in Figure 5-2.
		.57 #	

* Printout is red

Paired Statistics Checkout Procedure

A plotter is not required to perform any of this procedure

STEP: PRESS: PRINTOUT: COMMENTS:

CLEAR

1. VAR # 0
2. 1 DATA ENTRY
3. 2 DATA ENTRY
4. 3 DATA ENTRY
5. CHANGE SAMPLE
6. 5 DATA ENTRY
7. 4 DATA ENTRY
8. 3 DATA ENTRY
9. BASIC STAT

CLEAR		
2T		
	DATA 1	
	1.00	#
	2.00	#
	3.00	#
	DATA 2	
	5.00	#
	4.00	#
	3.00	#
N1		=
	3.00	#
x		=
	2.00	#
Δ1		=
	1.00	#
N2		=
	3.00	#
y		=
	4.00	#
Δ2		=
	1.00	#
	T	=
*	-	#
	2.45	#
	D	=
	4.00	#

BASIC STATISTICS printout.

Paired t printout

10. t

* Printout is red

**PRINTER
CHECKOUT
PROCEDURE**

NOTE

This procedure only checks the printer and not the printer drive circuits on the mother board. If a printer fails this test, the customer and kit printers should be exchanged to determine if the printer or the mother board is defective.

1. Perform the 'Printer Maintenance' procedure in Chapter 3.
2. Check printer operation by pressing the following keys—in order—and verifying that the resulting printout is identical to the one shown below:

(The **AUTO** and **PAT OFF** keys must be up.)

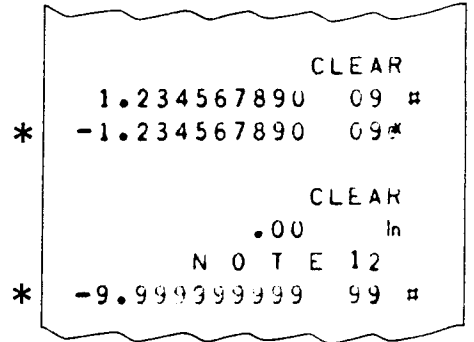
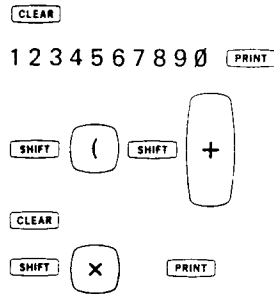

* Printout is red

3. If the resulting printout is identical to the above printout, the printer and printer drive circuits are operating correctly. Otherwise, exchange the printer with the kit printer to isolate the defective assembly (see the above NOTE).

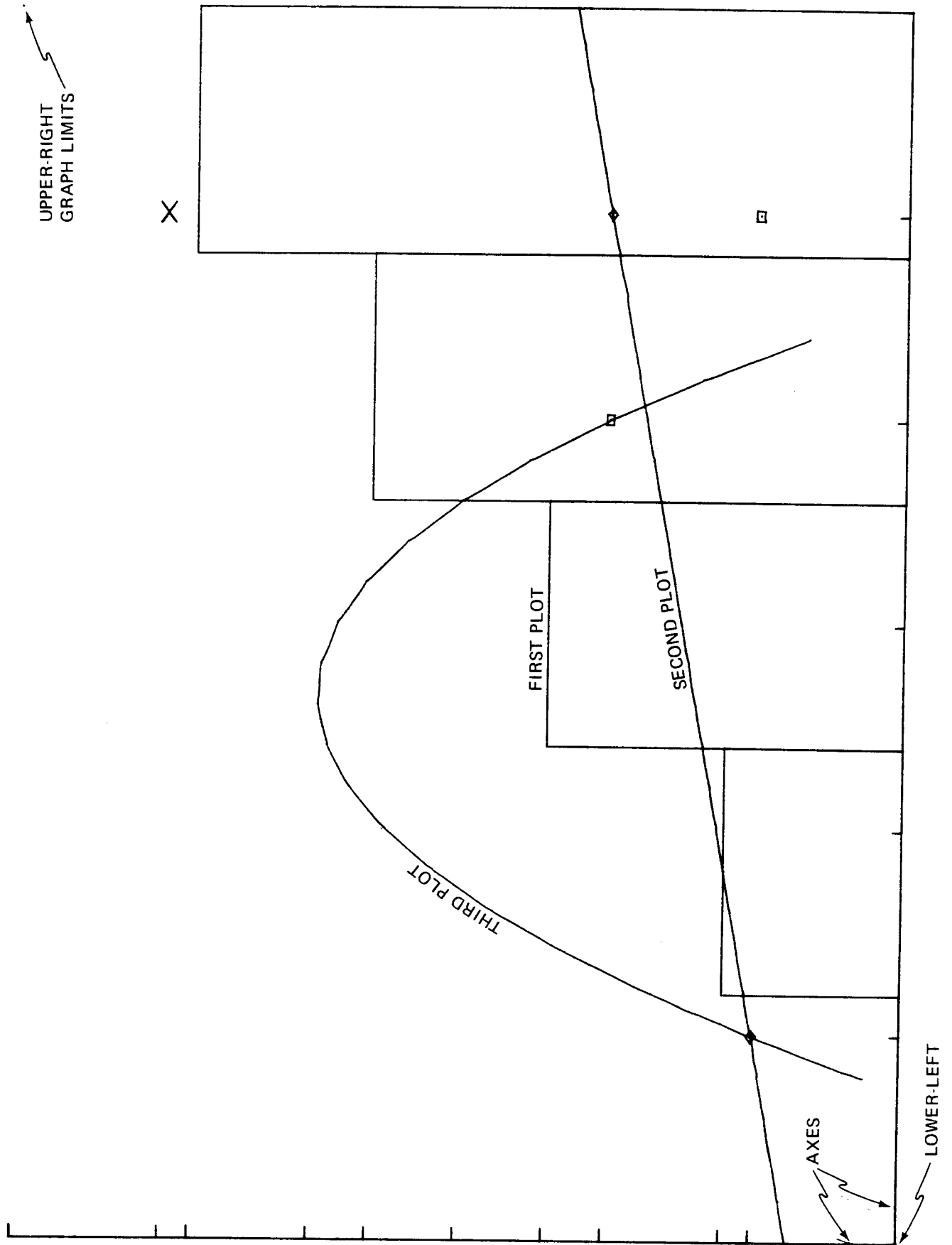

Figure 5-2. Results from STAT Keyblock Checkout Procedure.

Table 5-1. Model 5 Failure Symptoms

SYMPTOM	CHECK	PROBABLE CAUSE	ADDITIONAL INFORMATION
Blows fuses.	<ol style="list-style-type: none"> 1. Disconnect P1 & P2 Fuses still blow. 2. If fuses don't blow, remove all ass'y's except mother bd. Reconnect P1 & P2 - fuses blow? 3. Fuses don't blow. 	<p>Primary power short or T1 shorted. Exchange back panel ass'y.</p> <p>Primary dc power short on mother board - replace mother board.</p> <p>One of removed ass'y's has short. Reinstall one by one until defective ass'y blows fuse - replace.</p>	<p>P1 and P2 are shown in 'Primary Power Wiring Diagram'. If problem corrected, replace the defective component.</p> <p>Remove AC power while removing all assemblies.</p> <p>Be sure to switch unit OFF when installing any ass'y.</p>
Printer Okay - display defective.	<ol style="list-style-type: none"> 1. Raw +10V supply. 2. Exchange A41 ass'y. 	<p>Defective T1</p> <p>Defective display ass'y.</p>	<p>This supply is used for display only.</p>
Display Okay - printer inoperative.	<ol style="list-style-type: none"> 1. +15V supply. 2. Exchange printer. 3. Exchange the mother board. 	<p>Regulator Transistor on heat sink ass'y.</p> <p>Defective printer, printer cable, or connector.</p> <p>Defective printer control.</p>	<p>This supply is only used for printer.</p> <p>If CLEAR is the only printout, problem may be due to a defective PRINT OFF switch.</p>
Printer and/or display incorrect.	<ol style="list-style-type: none"> 1. Exchange the associated ass'y. 2. Exchange mother board. 	<p>Defective ass'y.</p> <p>Defective logic on mother board.</p>	<p>It's easier than replacing the mother board.</p>
Calculator okay except when using peripheral.	<ol style="list-style-type: none"> 1. Exchange the associated interface card then I/O cable. 2. Check PROM. 3. Exchange data register. 4. Exchange the A40 or A41 assemblies. 5. Exchange the mother board. 	<p>Defective I/O system.</p> <p>Defective PROM.</p> <p>Insufficient data registers.</p> <p>I/O data is processed on these assemblies.</p> <p>Defective output to the interface card.</p>	<p>Peripheral must be properly installed & operating correctly.</p>
Inoperative keyblock - key- board okay.	<ol style="list-style-type: none"> 1. Check keyblock connector on mother board. 2. Exchange keyblock. 	<p>Broken connector.</p> <p>Defective keyblock.</p>	<p>Repair by replacing mother board.</p>
Partially inoperative key- block, keyboard okay.	<ol style="list-style-type: none"> 1. Keyblock connector. 2. If not only PROM associated keys, exchange keyblock. 3. PROM keys only. 	<p>Broken connector.</p> <p>Defective keyblock.</p> <p>Defective PROM.</p>	<p>Repair by replacing mother board.</p>
Error note or keyboard control lost when key is pressed.	<ol style="list-style-type: none"> 1. Exchange keyboard. 2. Exchange A40 or A41 assembly. 3. Exchange mother board. 	<p>Defective keyboard.</p> <p>Defective mother board.</p>	
Inoperative or partially inoperative data storage.	<ol style="list-style-type: none"> 1. Exchange the optional data register ass'y. 2. Exchange A40 or A41 assembly. 3. Exchange the mother board. 	<p>Defective data storage ass'y.</p> <p>Incorrect input/output to data storage ass'y.</p>	
No keyboard control; 'BUSY' light on; printer ON but no printout.	<ol style="list-style-type: none"> 1. Exchange A40 or A41 ass'y, whichever is installed. 2. Exchange keyboard. 3. Exchange mother board. 	<p>Defective ass'y.</p> <p>Defective ass'y.</p> <p>Defective ass'y.</p>	<p>A defective component on one of these ass'ys may cause this symptom - order shown is for ease of replacement.</p>

Table 5-2. System PROM Tester Symptoms

SYMPTOM	CHECK	PROBABLE CAUSE	ADDITIONAL INFORMATION
Exerciser 10 fails:	<ol style="list-style-type: none"> 1. Remove all peripherals, I/O cards, and optional data storage. 2. If problem still exists exchange (A40) father or (A41) display board. 3. Exchange the printer. 4. Replace the mother board. 	<p>Not in basic machine.</p> <p>A40 or A41 failure.</p> <p>Printer failure.</p> <p>Mother board failure.</p>	<p>Problem may be caused by an optional assembly.</p> <p>Since the printer is used to output the results of the test, the printer may be the source of the problem.</p>
Exerciser 20 fails:	<ol style="list-style-type: none"> 1. Exchange any installed Data Storage Resisters. 	Failure on the optional data storage assemblies.	
Exerciser 30 fails:	<ol style="list-style-type: none"> 1. Exchange the Printer. 2. Exchange the (A40) or (A41) board. 3. Replace the mother board. 	<p>Printer failure.</p> <p>Mother board failure.</p>	Since Exerciser 10 runs properly, 2 and 3 are not probable failures.
Exerciser 40 fails:	<ol style="list-style-type: none"> 1. Exchange the plotter I/O card. 2. Check I/O cable and plotter. 	I/O card failure.	11390A Service Kit may be used with customer's I/O cable to check the I/O cable and plotter.

Table 6-1. Replaceable Parts

REFERENCE DESIGNATOR	hp- PART NO.	TQ	DESCRIPTION
	09805-90031	1	SYSTEM TEST PROM
	0515-0003	4	PRINTER SCREW
	5060-9199	1	POWER SUPPLY TEST BOARD
	09805-04101	1	COVER, BOTTOM
	09805-23751	1	SHAFT, PAPER
	0340-0416	1	INSULATOR, TRANSISTOR
	09805-00201	1	PANEL, REAR
	09805-21101	1	HEAT SINK
	09805-61603	1	LINE MODULE ASSY
C1	0150-0097	1	C, FXD; .0068 UF, 1000V
C2,C3	0160-3386	2	C, FXD; .001 UF, ±20%
A3	5060-9422	1	POWER MODULE
L1,L2	9100-0542	2	INDUCTOR, 60 UH
P1	1251-0524	1	CONNECTOR, SHELL
P2	1251-0525	1	CONNECTOR, SHELL
U1	1820-0430	1	IC, LINEAR
Q1	1854-0072	1	TRANSISTOR, 2N3054
CR1	1901-1001	1	DIODE PACKAGE
	2260-0001	6	NUT, HEX
	3101-1720	1	SWITCH, LINE
	8120-0593	1	POWER CABLE, SHIELDED
T1	9100-3299	1	TRANSFORMER, POWER
	09805-61220	1	BRACKET ASSEMBLY, STORAGE
	0403-0120	2	GUIDE PC BD RED
	0403-0119	1	GUIDE PC BD BRN
	0403-0121	2	GUIDE PC BD ORN
	0403-0152	2	GUIDE PC BD BLK
	09805-01222	1	PLATE, ROM
	09805-01223	1	PLATE, END
	09805-64401	1	CABINET ASSY, TOP
	5040-7402	1	WINDOW, DISPLAY
	7120-3220	1	NAMEPLATE, FRONT
*	0180-2565	2	C, FXD; 3000 UF, 30V
*	0180-2566	1	C, FXD; 12000 UF, 15V
	09805-90000	1	OPERATING GUIDE
	09805-90010	1	INSTRUCTION BOOKLET
	11357-61602	1	CABLE ASSY, PLOTTER I/O
F1	2110-0004	3	FUSE .25 AMP NB
F1	2110-0012	3	FUSE .5 AMP NB
	2360-0321	7	SCREW, MACHINE
	2360-0322	13	SCREW, MACHINE
	4040-0926	1	COVER, PRINTER
	4040-0971	1	CABINET, BOTTOM
	4040-0983	1	PAPER WELL
	5040-7026	3	PLUG, I/O COVER
	5040-7406	1	BASKET, KEYBLOCK
	5040-7407	1	GASKET, CABINET
	5040-7420	4	PAD, SUPPORT
	8120-1378	1	AC POWER CORD
	9211-1393	7	CARTON
	9211-1396	2	CARTON
	9211-1779	2	CARTON
	9220-1122	1	PAD, FOAM
	9281-0415	3	PRINTER PAPER
	9282-0511	1	PRINTER RIBBON
	1540-0138	2	PLASTIC BOX

*Component located on motherboard.

Chapter 6

REPLACEABLE PARTS

INTRODUCTION

This chapter contains information for ordering calculator replacement parts. The chapter consists of one table and two figures. Figure 6-1 shows the part numbers for keyboard keycaps. Figure 6-2 is a primary power wiring diagram. Part numbers for Figure 6-2 are referenced to Table 6-1, the replaceable parts list. Table 6-1 contains -hp- ordering information only; manufacturers' part numbers are not provided.

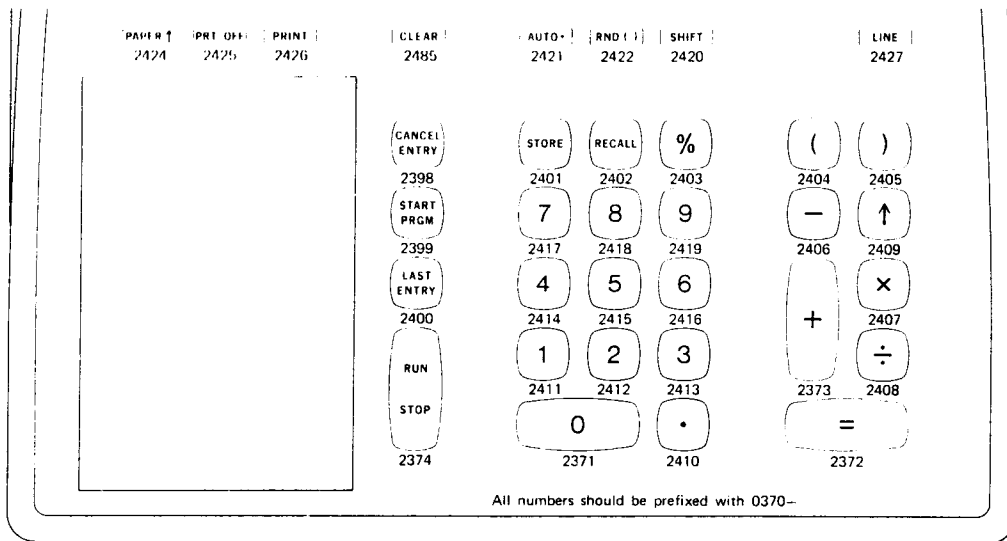

Figure 6-1. Keycap Part Numbers

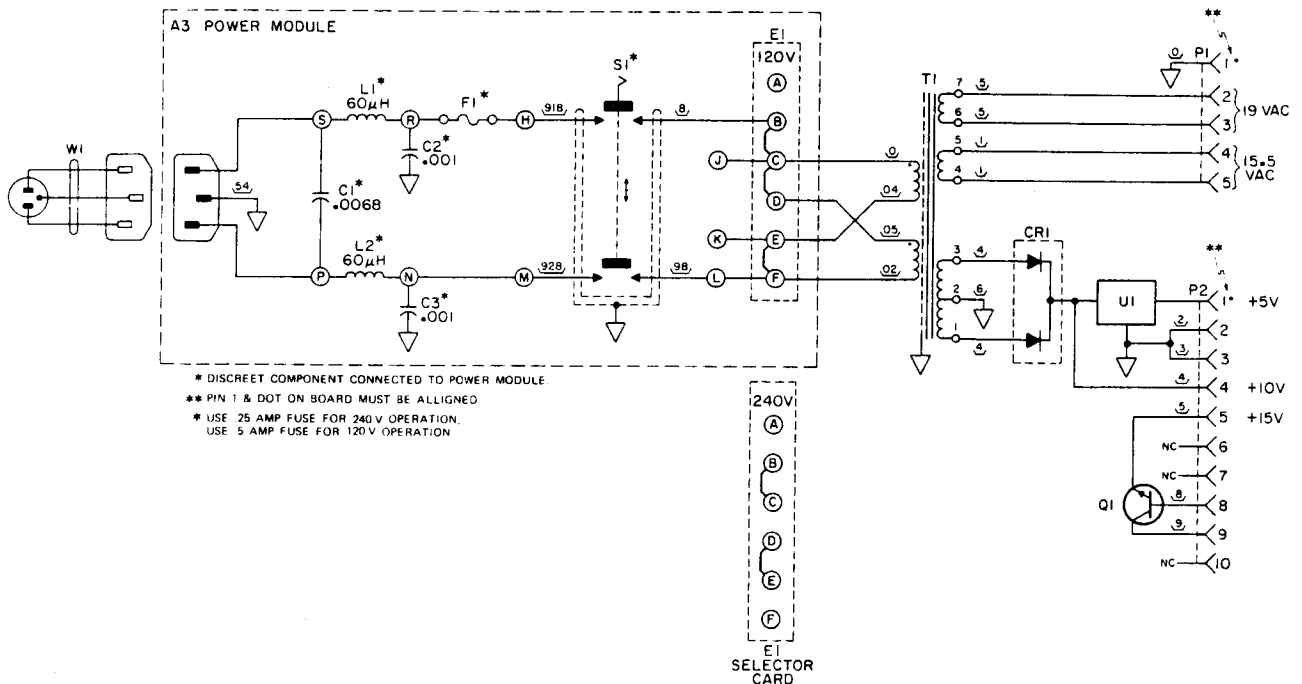

Figure 6-2. Primary Power Schematic

