

HEWLETT-PACKARD

# HP-41C

## THERMAL & TRANSPORT SCIENCE PAC

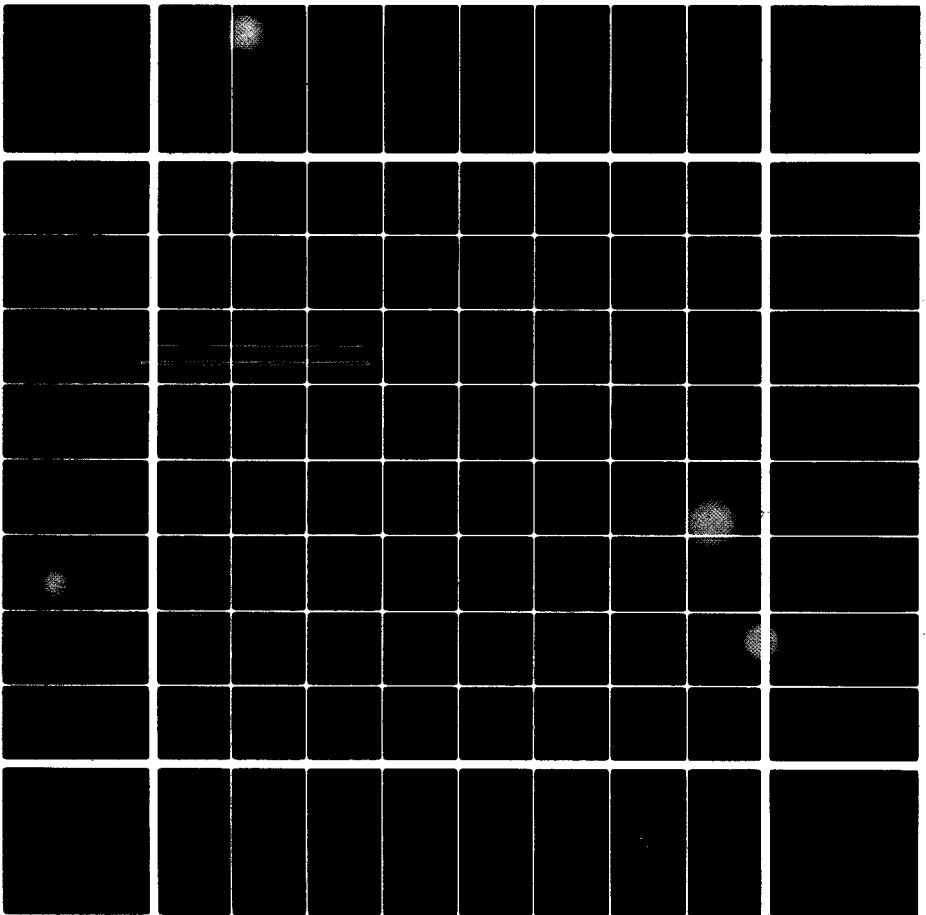

## NOTICE

The program material contained herein is supplied without representation or warranty of any kind. Hewlett-Packard Company therefore assumes no responsibility and shall have no liability, consequential or otherwise, of any kind arising from the use of this program material or any part thereof.

## HEWLETT-PACKARD LISTENS

To provide better calculator support for you, the Application Engineering group needs your help. Your timely inputs enable us to provide higher quality software and improve the existing application pacs for your calculator. Your reply will be extremely helpful in this effort.

1. Pac name \_\_\_\_\_
2. How important was the availability of this pac in making your decision to buy a Hewlett-Packard calculator?  
 Would not buy without it.     Important     Not important
3. What is the major application area for which you purchased the pac?  
 \_\_\_\_\_

4. In the list below, please rate the usefulness of the programs in this pac.

PROGRAM NUMBER	ESSENTIAL	IMPORTANT BUT NOT REQUIRED	INFREQUENTLY USED	NEVER USED
1				
2				
3				
4				
5				
6				
7				
8				

PROGRAM NUMBER	ESSENTIAL	IMPORTANT BUT NOT REQUIRED	INFREQUENTLY USED	NEVER USED
9				
10				
11				
12				
13				
14				
15				
16				

5. Did you purchase a printer?     YES     NO  
 If you did, is the printing format in this pac useful?     YES     NO
6. What programs would you add to this pac?  
 \_\_\_\_\_

7. What additional application pacs would you like to see developed?  
 \_\_\_\_\_

THANK YOU FOR YOUR TIME AND COOPERATION.

Name \_\_\_\_\_ Position \_\_\_\_\_

Company \_\_\_\_\_

Address \_\_\_\_\_

City \_\_\_\_\_ State \_\_\_\_\_

Zip \_\_\_\_\_ Phone \_\_\_\_\_

Please fold and staple for mailing.

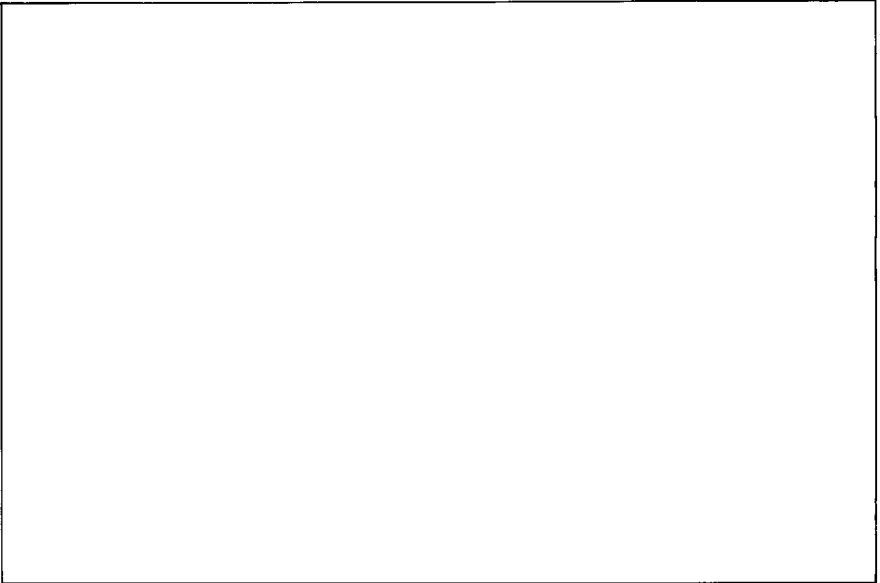

Additional Comments:



NO POSTAGE  
NECESSARY  
IF MAILED  
IN THE  
UNITED STATES

**BUSINESS REPLY MAIL**

FIRST CLASS PERMIT NO. 33 CORVALLIS, OREGON

*Postage will be paid by*

**Hewlett-Packard**  
1000 N.E. Circle Blvd.  
Corvallis, Oregon 97330

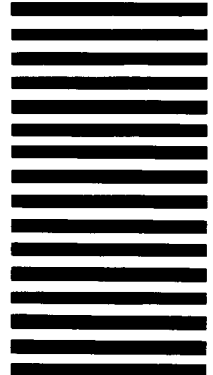

## INTRODUCTION

This HP-41C application pac is designed to solve a variety of problems involving fluid flow, gas behavior, and heat transfer. In order to make these solutions more useful a unique *Unit Management System* is incorporated. This system allows you to specify the units of your inputs and outputs, removing the burden of unit conversion from problem solution.

Each program in this pac is represented by one program in the Application Module and a section in this manual.

The manual provides a description of each program, a set of instructions for using each program, and one or more example problems, each of which includes a list of the keystrokes required for its solution.

Before plugging in your Application Module, **turn your calculator off**, and be sure you understand the section *Inserting and Removing Application Modules*. Before using a particular program, take a few minutes to read *Format of User Instructions* and *A Word About Program Usage*.

You should first familiarize yourself with a program by running it once or twice while following the complete User Instructions in the manual. Thereafter, the program's prompting should provide the necessary instructions, including which variables are to be input, which keys are to be pressed, and which values will be output.

We hope this pac will assist you in the solution of numerous problems in your discipline. We would appreciate knowing your reactions to the programs, and to this end we have provided a questionnaire inside the front cover of this manual. Would you please take a few minutes to give us your comments on these programs? It is from your comments that we learn how to increase the usefulness of our programs.

# CONTENTS

<b>Introduction</b> .....	<b>1</b>
<b>Contents</b> .....	<b>2</b>
<b>Inserting and Removing Application Modules</b> .....	<b>3</b>
<b>Format of User Instructions</b> .....	<b>5</b>
<b>A Word About Program Usage</b> .....	<b>6</b>
<b>Unit Management System</b> .....	<b>8</b>
<b>Equations of State</b> .....	<b>17</b>
Ideal gas relation plus Redlich-Kwong model of real gas behavior.	
<b>Polytropic Processes for an Ideal Gas</b> .....	<b>23</b>
Compression and expansion processes for ideal gases.	
<b>Isentropic Flow for Ideal Gases</b> .....	<b>25</b>
High velocity compressible flow of ideal gases.	
<b>Conduit Flow</b> .....	<b>28</b>
Flow of non-compressible fluids and low velocity flow of compressible fluids.	
<b>Energy Equation for Steady Flow</b> .....	<b>34</b>
Converts between head, velocity, elevation, and kinetic energy for fluid flow.	
<b>Heat Exchangers</b> .....	<b>39</b>
Performs analysis of counter-flow, parallel-flow, parallel-counter-flow and cross-flow (fluids unmixed) heat exchangers.	
<b>Black Body Thermal Radiation</b> .....	<b>48</b>
Calculates the emissive power of a black body as a function of temperature and wavelength.	
<b>Appendix A—Program Data</b> .....	<b>52</b>

## INSERTING AND REMOVING APPLICATION MODULES

Before you insert an Application Module for the first time, familiarize yourself with the following information.

Up to four Application Modules can be plugged into the ports on the HP-41C. While plugged in, the names of all programs contained in the Module can be displayed by pressing  CATALOG 2.

### CAUTION

Always turn the HP-41C off before inserting or removing any plug-in extension or accessories. Failure to turn the HP-41C off could damage both the calculator and the accessory.

### To insert Application Modules:

1. Turn the HP-41C off! Failure to turn the calculator off could damage both the Module and the calculator.

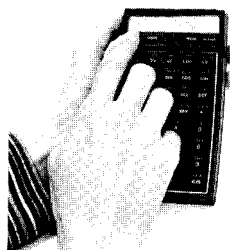

2. Remove the port covers. Remember to save the port covers; they should be inserted into the empty ports when no extensions are inserted.

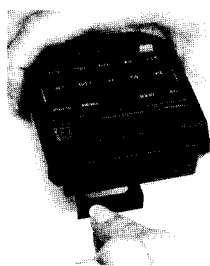

3. Insert the Application Module with the label facing downward as shown, into any port **after** the last Memory Module. For example, if you have a Memory Module inserted in port 1, you can insert an Application Module in any of ports 2, 3, or 4. (The port numbers are shown on the back of the calculator.) **Never insert an Application Module into a lower numbered port than a Memory Module.**

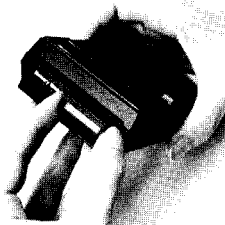

4. If you have additional Application Modules to insert, plug them into any port after the last Memory Module. Be sure to place port covers over unused ports.
5. Turn the calculator on and follow the instructions given in this book for the desired application functions.

**To remove Application Modules:**

1. Turn the HP-41C off! Failure to do so could damage both the calculator and the Module.
2. Grasp the desired Module handle and pull it out as shown.



3. Place a port cap into the empty ports.

**Mixing Memory Modules and Application Modules**

Any optional accessories (such as the HP 82104A Card Reader, or the HP 82143A Printer) should be treated in the same manner as Application Modules. That is, they can be plugged into any port after the last Memory Module. Also, the HP-41C should be turned off prior to insertion or removal of these extensions.

The HP-41C allows you to leave gaps in the port sequence when mixing Memory and Application Modules. For example, you can plug a Memory Module into port 1 and an Application Module into port 4, leaving ports 2 and 3 empty.



## FORMAT OF USER INSTRUCTIONS

The completed User Instruction Form—which accompanies each program—is your guide to operating the programs in this Pac.

The form is composed of five labeled columns. Reading from left to right, the first column, labeled STEP, gives the instruction step number.

The INSTRUCTIONS column gives instructions and comments concerning the operations to be performed.

The INPUT column specifies the input data, the units of data if applicable, or the appropriate alpha response to a prompted question. Data input keys consist of 0 to 9 and the decimal point (the numeric keys), **EEEX** (enter exponent), and **CHS** (change sign).

The FUNCTION column specifies the keys to be pressed after keying in the corresponding input data.

The DISPLAY column specifies prompts, intermediate and final answers, and their units, where applicable.

Above the DISPLAY column is a box which specifies the minimum number of data storage registers necessary to execute the program. Refer to the Owner's Handbook for information on how the SIZE function affects storage configuration.

## A WORD ABOUT PROGRAM USAGE

### Catalog

When an Application Module is plugged into a port of the HP-41C, the contents of the Module can be reviewed by pressing **▀** **CATALOG** 2 (the Extension Catalog). Executing the **CATALOG** function lists the name of each program or function in the Module, as well as functions of any other extensions which might be plugged in.

### ALPHA and USER Mode Notation

This manual uses a special notation to signify ALPHA mode. Whenever a statement on the User Instruction Form is printed in gold, the **ALPHA** key must be pressed before the statement can be keyed in. After the statement is input, press **ALPHA** again to return the calculator to its normal operating mode, or to begin program execution. For example, **XEQ** KWONG means press the following keys: **XEQ** **ALPHA** KWONG **ALPHA**.

When the calculator is in USER mode, this manual will use the symbols **A** - **J** and **▀** **A** - **▀** **E** to refer to the reassigned keys in the top two rows. These key designations will appear on the User Instruction Form and in the keystroke solutions to sample problems.

### Optional HP 82143A Printer

When the optional printer is plugged into the HP-41C along with this Application Module, all inputs and results will be printed automatically. The printer mode switch should be set to MANUAL mode.

### Downloading Module Programs

If you wish to trace execution, to modify, to record on magnetic cards, or to print a program in this Application Module, it must first be copied into the HP-41C's program memory. For information concerning the HP-41C's COPY function, see the Owner's Handbook. It is not necessary to copy a program in order to run it.

## **Program Interruption**

These programs have been designed to operate properly when run from beginning to end, without turning the calculator off (remember, the calculator may turn itself off). If the HP-41C is turned off, it may be necessary to set flag 21 (SF 21) to continue proper execution.

## **Use of Labels**

You should generally avoid writing programs into the calculator memory that use program labels identical to those in your Application Module. In case of a label conflict, the label within program memory has priority over the label within the Application Pac program.

## **Assigning Program Names**

Key assignments to keys **A** - **J** and **■A** - **■E** take priority over the automatic assignments of local labels in the Application Module. Be sure to clear previously assigned functions before executing a Module program.

## UNIT MANAGEMENT SYSTEM

In many applications the difficulty of computation is secondary to the difficulties of unit conversion and of dimensional homogeneity. The programs in this application pac were written to solve both the computational and dimensional aspects of your problems.

Upon initialization, some of the programs in this application pac will prompt as follows:

### UNT CNV? Y/N

If you wish to manage the units yourself key "N" and press **R/S**. This clears the *unit* mode. With *unit* mode clear all programs will work as long as your inputs have compatible units. If you key "Y" and press **R/S** unit mode will be set. The calculator will request both the number and the associated units for each input. For instance, the calculator might prompt for length:

L=?

You would respond with a number and press **R/S**. The calculator would then ask for the units associated with that number:

### UNITS L?

You would key in the abbreviation for the units. In this case "FT" (abbreviation for feet) would be an appropriate response. After keying in the units press **R/S**. The calculator should continue to the next input prompt or to the output routine.

Output is very similar to input. If the calculator were ready to output the area A it would display:

### UNITS A?

You might respond with "IN2" (the abbreviation for square inches).

If you key in a value or want an output in SI (*International System*) units, you may ignore the unit prompt and press **R/S**. This shortcut is particularly useful when an input of zero has just been made. With the exception of temperature, the units of zero are unimportant.

If the prompt comes right back after you press **R/S** an error was found in the unit string. Four common errors are:

1. The units specified were incompatible with the requested input or output (e.g., the prompt was for length and the response was seconds).
2. Unit control characters (\*, /, -, 1-9) were incorrectly used (e.g., FT/s/s).
3. More than 12 characters were used to specify the units.
4. The units keyed in are misspelled, used lower case letter, or are not included in the following list (e.g., "FEET" for "FT"):

## UNIT CONVERSIONS

HP-41C Abbreviation	Name	Multiplicative Conversion Constant	Homogeneous SI UNIT
ANG	angstrom	$1.0 \times 10^{-10}$	m
ATM	atmosphere	$1.01325 \times 10^5$	Pa
BAR	bar	$1.0 \times 10^5$	Pa
BBL	barrel of petroleum	$1.589873 \times 10^{-1}$	m <sup>3</sup>
BTU	British Thermal Unit (IST)	$1.055056 \times 10^3$	J
C	degree celsius	$1.0 \times 10^0$ ( $\pm 273.15$ )	K
CAL	calorie (IST)	$4.1868 \times 10^0$	J
CM	centimeter	$1 \times 10^{-2}$	m
DAY	day (mean solar)	$8.64 \times 10^4$	s
DYNE	dyne	$1.0 \times 10^{-5}$	N
ERG	erg	$1.0 \times 10^{-7}$	J
F	degree Fahrenheit	$5.55555555 \times 10^{-1}$ ( $\pm 459.67$ )	K
FT	foot	$3.048 \times 10^{-1}$	m
FTH2O	foot of water (39.2°F)	$2.98898 \times 10^3$	Pa
G	gram	$1.0 \times 10^{-3}$	kg
GAL	gallon (U.S.)	$3.785411784 \times 10^{-3}$	m <sup>3</sup>
HP	horsepower (550 ft. lbf/s)	$7.4569987 \times 10^2$	W
HR	hour (mean solar)	$3.6 \times 10^3$	s
IN	inch	$2.54 \times 10^{-2}$	m
INHG	inch of mercury (60°F)	$3.37685 \times 10^3$	Pa
INH2O	inches of water (60°F)	$2.4884 \times 10^2$	Pa
J	joule	$1.0 \times 10^0$	J
K	kelvin	$1.0 \times 10^0$	K
KCAL	kilocalorie (IST)	$4.1868 \times 10^3$	J
KG	kilogram	$1.0 \times 10^0$	kg
KGF	kilogram force	$9.80665 \times 10^0$	N
KIP	1000 pounds force	$4.448221615 \times 10^3$	N
KM	kilometers	$1.0 \times 10^3$	m
KPA	kilopascals	$1.0 \times 10^3$	Pa
KW	kilowatt	$1.0 \times 10^3$	W
LBF	pound force	$4.448221615 \times 10^0$	N
LBM	pound mass	$4.5359237 \times 10^{-1}$	kg
L	liter	$1.0 \times 10^{-3}$	m <sup>3</sup>
M	meter	$1.0 \times 10^0$	m
MI	mile	$1.609344 \times 10^3$	m
MIC	micron	$1.0 \times 10^{-6}$	m
MIL	1/1000 inch	$2.54 \times 10^{-5}$	m

## 10 Unit Management System

MIN	minute	$6.0 \times 10^1$	s
ML	1/1000 liter	$1.0 \times 10^{-6}$	m <sup>3</sup>
MM	1/1000 meter	$1.0 \times 10^{-3}$	m
MOLE	mole	$1.0 \times 10^0$	mole
N	newton	$1.0 \times 10^0$	N
PA	pascal	$1.0 \times 10^0$	Pa
PDL	poundal	$1.382549544 \times 10^{-1}$	N
PSF	pounds force per square foot	$4.788025833 \times 10^1$	Pa
PSI	pounds force per square inch	$6.8947572 \times 10^3$	Pa
POISE	poise	$1.0 \times 10^{-1}$	N · s/m <sup>2</sup>
R	degree rankine	$5.555555555 \times 10^{-1}$	K
S	second	$1.0 \times 10^0$	s
SLUG	slug	$1.45939029 \times 10^1$	kg
STOKE	stoke	$1.0 \times 10^{-4}$	m <sup>2</sup> /s
TON	ton (2000 lb)	$9.0718474 \times 10^2$	kg
TORR	torr (0 °C)	$1.33322 \times 10^2$	Pa
W	watt	$1.0 \times 10^0$	W
YD	yard	$9.144 \times 10^{-1}$	m
NULL STRING		$1.0 \times 10^0$	

You can combine units using the unit control characters. For instance, an acceleration of feet per second squared would be keyed in as:

***FT/S\*S***

or

***FT/S2***

Legal options for volumetric flow rate include, but are far from limited too:

***FT3/S***  
***M\*CM\*IN/S***  
***FT3\*HR/S2***  
etc.

Only one divide is allowed in the unit string. Thus all units to the right of the divide sign are included in the denominator.

The dash or minus character stands for "convert to". Thus,

***FT3 - M3***

is read "feet cubed, converted to meters cubed." Only one dash is allowed in a unit string.

Digits one through nine indicate the power to which a unit should be raised.

## Automatic Unit Conversion in Your Programs

The *Unit Management System* of this application pac is completely subroutineable. You may take advantage of its capabilities from your programs or from the keyboard.

Two functions form the basis of the capability. They are `-SI` and `SI-`.

The abbreviations stand for "to International System of Units" and "from International System of Units." In the simplest mode of operation, these functions take values in the X-register and transform them to or from SI units according to the unit string in the ALPHA-register. The base SI units used in this pac are:

Pac Abbreviation	Name	Type of Unit
K	kelvin	temperature
M	meter	length
KG	kilogram	mass
S	seconds	time
MOLE	mole	amount of material

Other SI units are formed from combinations of these base units.

Both `-SI` and `SI-` modify X, and LAST X. They do not alter any other registers. In the case of "DATA ERROR" nothing is altered except flag 25 which is cleared if it was set.

Example of `-SI` and `SI-`:

Convert 12 inches to meters.

Keystrokes	Display
<b>FIX</b> 2	
12	<b>12</b>
<b>ALPHA</b> IN	<b>IN</b>
<b>ALPHA</b>	<b>12.00</b>
<b>XEQ</b> <b>ALPHA</b> <code>-SI</code> <b>ALPHA</b>	<b>0.30</b>

Convert the result to feet.

<b>ALPHA</b> FT <b>ALPHA</b>	<b>0.30</b>
<b>XEQ</b> <b>ALPHA</b> <code>SI-</code> <b>ALPHA</b>	<b>1.00</b>

The functions `-SI` and `SI-` can also be used to do more complicated conversions by employing the dash or *to* operator.

Example of `-SI` and `SI-` using the *to* operator:

Convert 12 inches to feet using `-SI` and the *to* operator.

Keystrokes	Display
<b>FIX</b> 2	
12	<b>12</b>
<b>ALPHA</b> IN-FT <b>ALPHA</b>	<b>12.00</b>
<b>XEQ</b> <b>ALPHA</b> -SI <b>ALPHA</b>	<b>1.00</b>

Convert feet back to inches using the SI- function.

<b>XEQ</b> <b>ALPHA</b> SI- <b>ALPHA</b>	<b>12.00</b>
--	--------------

An important advantage of using the *to* operator is that dimensional homogeneity is checked. When using the *to* operator, attempts to convert between incompatible units such as feet and seconds will result in "DATA ERROR."

Four other routines in this application pac are of interest if you wish to write programs using the *Unit Management System*. Skip the following discussion if you do not wish to write your own programs.

1. **SZ?** does a paper advance and checks to see if size is adequate for program execution. The necessary size must be placed in X on input. The routine halts displaying:

**SIZE>=NNN**

If size is inadequate, otherwise it returns to the point of call.

```
17*LBL "SZ?"
CF 01 ADV "SIZE>="
ARCL X SF 25 1 -
RCL IND X FS?C 25 RTN
PROMPT
```

```
29*LBL 02
"RE-XEQ FNC" PROMPT
GTO 02
```

2. **UNIT?** Sets the two unit control flags (00,01), checks **SIZE** and stores null alpha strings in R01 and R02. Since **UNIT?** calls **SZ?**, the minimum allowable register size must be in X when **UNIT?** is called.

```
01*LBL "UNIT?"
CF 00 XEQ "SZ?" "Y"
ASTO Y "UNT CHV? Y/N"
AON PROMPT ASTO X
X=Y? SF 00 AOFF CLA
ASTO 01 ASTO 02 RTN
```



3. INPUT increments R00, prompts for an input, optionally prompts for the units of that input, converts the input to the units specified by R01 and R02, stores the input, and prints the input if a printer is being used. If flag 00 is set the unit conversion option is invoked. However, if flag 01 is set flag 00 is ignored. Flag 01 is cleared on exit. Flag 00 is not changed. Upon entry, the following register usage is required:

- a. R00 contains the address minus one of the register into which the data should be placed;
- b. The ALPHA register should contain the variable name (5 characters or less);
- c. Registers 01 and 02 should contain a 12 character alpha string specifying the units, to which the User's input must be converted for proper program execution. A null string in R01 and R02 will default conversion to SI units. No homogeneity checking is possible in this case.

Upon exit, the users input (including units) is printed. R01 and R02 are unchanged. R00 has been incremented by one. The converted input value is stored in the register *currently* pointed to by R00 and is also in the X-register.

```

33*LBL "INPUT"
CF 22 1 ST+ 00
RCL IND 00 ASTO Y
"F=?" CF 21 AVIEW
SF 21 CLA ARCL Y STOP
STO L ASTO Y CLA
ASTO Z ASTO T ARCL Y
FS?C 01 GTO 00 FC? 22
GTO 00 FS? 00 XEQ 01

```

```

58*LBL 00
STO IND 00 FC? 22 RTN
"F=" ARCL L "F "
ARCL Z ARCL T FS? 55
PRA RTN

```

4. OUTPUT takes a value in X, optionally prompts the user for the output units, converts the output to those units and prints or displays the result. Flags 00 and 01 are used in a manner analogous to their use in INPUT.

Upon entry, the following register usage is required:

- a. The ALPHA register contains the name of the variable (5 characters or less);
- b. The X register contains the calculated value;

- c. Registers 01 and 02 contain a 12 character string specifying the units of the calculated value. A null string implies that the calculated value is in SI units but no homogeneity checking is possible for null strings.

Upon exit, the alpha register contains the formatted answer which is either printed or displayed. Registers 01 and 02 are unchanged.

```

70+LBL "OUTPUT"
STO L FS?C 01 GTO 00
FC? 00 GTO 00 SF 01
BEEP

78+LBL 01
ASTO Y "UNITS " ARCL Y
"F?" AON CF 23 PROMPT
AOFF FC? 23 CLA
FC? 23 ARCL 01 FC? 23
ARCL 02 ASTO Z ASHF
ASTO T CLA ARCL Z
ARCL T "F-" ARCL 01
ARCL 02 SF 25 FS? 01
XEQ "SI-" FC? 01
XEQ "-SI" CLA ARCL Y
FC?C 25 GTO 01 FC?C 01
RTN "F=" ARCL X "F "
ARCL Z ARCL T AVIEW
RTN

120+LBL 00
"F=" ARCL X AVIEW RTN

```

Example program using *Unit Management System*:

Given a mass  $M$  and an acceleration  $A$  compute the force  $F$ .

FLOWCHART  $F = MA$

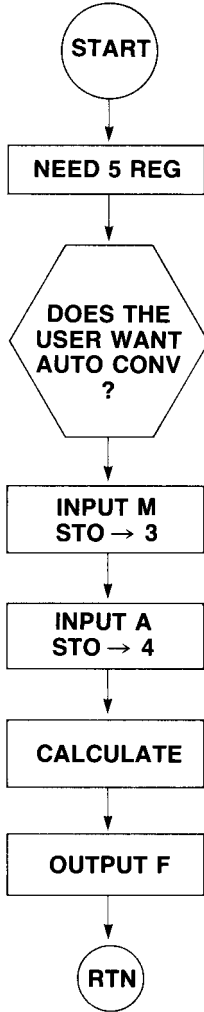

## PROGRAM F=MA

Program Line	Comments
LBL F=MA	
5	Uses 5 registers.
XEQ UNIT?	Initialize. At user's option select automatic unit conversion.
2	Start storing inputs at R03.
STO 00	
"KG" } †	First input is to be converted to kilograms.
ASTO 01 } †	
"M"	The name of the first input is M.
XEQ INPUT	Get input (and units).
"M/S <sup>2</sup> " } †	The second input is to be converted to meters per second per second.
ASTO 01 } †	
"A"	The name of the second input is A.
XEQ INPUT	Get input.
RCL 03	Calculate answer.
RCL 04	
*	
"N" } †	The calculated answer is in newtons.
ASTO 01 } †	
"F"	The name of the answer is F.
XEQ OUTPUT	
RTN	

† Optional, but deletion will eliminate homogeneity checking.

Example of program F=MA:

A car with a mass of 2500 pounds accelerates at 3 miles per hour per second. What force in pounds is being applied?

**Keystrokes (SIZE>=005)**

**Display**

(First key the program in and insert the application module).

■ **FIX** 2

**XEQ** **ALPHA** F=MA **ALPHA**

Y **R/S**

2500 **R/S**

LBM **R/S**

3 **R/S**

MI/HR\*S **R/S**

LBF **R/S**

**UNT CNV? Y/N**

**M=?**

**UNIT=M?**

**A=?**

**UNITS A=?**

**UNITS F=?**

**F=341.89 LBF**

## EQUATIONS OF STATE

This program solves for any one of the following four variables, given the other three:

1. pressure;
2. volume;
3. mass (or number of moles);
4. temperature.

The ideal gas rule is selected by executing IDEAL. The Redlich-Kwong model of real gas behavior is selected by executing KWONG. The Redlich-Kwong solution requires the critical temperature and pressure of the gas.

Solution may be on a mass or mole basis. When the program prompts for molecular weight key in 1.00 if you wish solution on a mole basis. If you wish solution on a mass basis specify the actual molecular weight. The program will subsequently prompt or label output using the character "N" for number of moles or "M" for mass.

The *Unit Management System* may be used with this program. If the *Unit Management System* is used the ideal gas constant R is automatically selected. If the system is not used you must supply R in units compatible with your other inputs.

### Values of the Universal Gas Constants

Value of R	Units of R	Units of P	Units of V	Units of T
8314.34	N · m/kg · mole · K	N/m <sup>2</sup>	m <sup>3</sup> /kg mole	K
83.1434	cm <sup>3</sup> · bar/g · mole · K	bar	cm <sup>3</sup> /g mole	K
82.05	cm <sup>3</sup> · atm/g · mole · K	atm	cm <sup>3</sup> /g mole	K
0.7302	atm · ft <sup>3</sup> /lb · mole · °R	atm	ft <sup>3</sup> /lb mole	°R
10.73	psi · ft <sup>3</sup> /lb · mole · °R	psi	ft <sup>3</sup> /lb mole	°R
1545	psf · ft <sup>3</sup> /lb · mole · °R	psf	ft <sup>3</sup> /lb mole	°R

## Critical Temperatures and Pressures

Substance	$T_c$ , K	$T_c$ , °R	$P_c$ , ATM
Ammonia	405.6	730.1	112.5
Argon	151	272	48.0
Carbon dioxide	304.2	547.6	72.9
Carbon monoxide	133	239	34.5
Chlorine	417	751	76.1
Helium	5.3	9.5	2.26
Hydrogen	33.3	59.9	12.8
Nitrogen	126.2	227.2	33.5
Oxygen	154.8	278.6	50.1
Water	647.3	1165.1	218.2
Dichlorodifluoromethane	384.7	692.5	39.6
Dichlorofluoromethane	451.7	813.1	51.0
Ethane	305.5	549.9	48.2
Ethanol	516.3	929.3	63
Methanol	513.2	923.8	78.5
n-Butane	425.2	765.4	37.5
n-Hexane	507.9	914.2	29.9
n-Pentane	469.5	845.1	33.3
n-Octane	568.6	1023.5	24.6
Trichlorofluoromethane	471.2	848.1	43.2

## Equations:

Ideal gas:

$$PV = nRT$$

Redlich-Kwong:

$$P = \frac{nRT}{(V - b)} - \frac{a}{T^{1/2} V(V + b)}$$

$$a = 4.934 b nRT_c^{1.5}$$

$$b = 0.0867 \frac{nRT_c}{P_c}$$

where:

P is the absolute pressure;

V is the volume;

n is the number of moles present;

R is the universal gas constant;

T is the absolute temperature;

 $T_c$  is the critical temperature; $P_c$  is the critical pressure.

**Remarks:**

At low temperatures or high pressures, the ideal gas law does not represent the behavior of real gases.

No equation of state is valid for all substances, nor over an infinite range of conditions. The Redlich-Kwong equation gives moderate to good accuracy for a variety of substances over a wide range of conditions. Results should be used with caution and tempered by experience.

SIZE: 014				
STEP	INSTRUCTIONS	INPUT	FUNCTION	DISPLAY
1	Initialize program.		<input type="checkbox"/> <b>IDEAL</b>	UNT CNV? Y/N
2	If you wish automatic unit conversion key "Y", if not key "N".	Y or N	<input type="checkbox"/> <b>R/S</b>	(R=?)
3	If you answered yes above you will not see the "R=?" prompt and you may skip to step 5.			
4	Key in ideal gas constant.	R	<input type="checkbox"/> <b>R/S</b>	M WT=?
5	Key in molecular weight if you wish to work on a mole basis.	molecular weight	<input type="checkbox"/> <b>R/S</b>	P=?
6	If you know pressure key it in, if not press <input type="checkbox"/> <b>R/S</b> .	P	<input type="checkbox"/> <b>R/S</b>	V=?
7	If you know the volume key it in.	V	<input type="checkbox"/> <b>R/S</b>	N=? or M=?
8	If you know number of moles or mass key it in.	N or M	<input type="checkbox"/> <b>R/S</b>	T=?
9	If you know temperature key it in.	T	<input type="checkbox"/> <b>R/S</b>	SELECT KEY: P V M/N T
10	By now you should have keyed in three of the four inputs in steps six through nine. Calculate remaining value. Press <input type="checkbox"/> <b>A</b> for pressure, <input type="checkbox"/> <b>B</b> for volume, <input type="checkbox"/> <b>C</b> for amount of material, or <input type="checkbox"/> <b>D</b> for temperature.		<input type="checkbox"/> <b>A</b> , <input type="checkbox"/> <b>B</b> , <input type="checkbox"/> <b>C</b> or <input type="checkbox"/> <b>D</b>	P=;V=;M=; N=; or T= P=?
11	For a new case involving the same gas go to step 6. For a totally new case go to step 1. It is not necessary to key in any values which do not change. Ignore the prompt and press <input type="checkbox"/> <b>R/S</b> .  *Press <input type="checkbox"/> <b>R/S</b> if you are not using a printer.		<input type="checkbox"/> <b>R/S</b> *	

## Example 1:

0.63 g moles of air are enclosed in a 25,000 cm<sup>3</sup> space at 1200 K. What is the pressure in bars? Assume an ideal gas. Do not use the *Unit Management* option.

## Keystrokes (SIZE ≥ 014)

## Display

■ **FIX** 2

**XEQ** **ALPHA** IDEAL **ALPHA**

**UNIT CNV? Y/N**

N **R/S**

**R=?**

Select R (cm<sup>3</sup> · bar/g · mole · K).

83.1434 **R/S**

**M WT=?**

For a mole basis key 1.00.

1 **R/S**

**P=?**

**R/S**

**V=?**

25000 **R/S**

**N=?**

.63 **R/S**

**T=?**

1200 **R/S**

**"SELECT KEY:"**

**P V M T**

**A**

**P=2.51**

(bar)

## Example 2:

What is the specific volume (ft<sup>3</sup>/lbm) of a gas at atmospheric pressure and at a temperature of 55°F? The molecular weight is 29. Assume an ideal gas. Use *Unit Management*.

## Keystrokes (SIZE ≥ 014)

## Display

■ **FIX** 2

**XEQ** **ALPHA** IDEAL **ALPHA**

**UNIT CNV? Y/N**

Y **R/S**

**M WT=?**

29 **R/S**

**P=?**

1 **R/S**

**UNITS P?**

ATM **R/S**

**V=?**

**R/S**

**M=?**

1 **R/S**

**UNITS M?**

LBM **R/S**

**T=?**

55 **R/S**

**UNITS T?**

F **R/S**

**"SELECT KEY:"**

**P V M T**

**B**

**UNITS V?**

FT3 **R/S**

**V=12.96 FT3**



If the pressure were increased to 19.40 psi what would V be?

**R/S** \*  
 19.4 **R/S**  
 PSI **R/S**  
**R/S**  
**R/S**  
**R/S**

**P=?**  
**UNITS P?**  
**V=?**  
**M=?**  
**T=?**  
**"SELECT KEY:"**  
**P V M T**  
**UNITS V?**  
**V=9.82 FT3**

**B**  
 FT3 **R/S**

### Example 3:

The specific volume of a gas in a container is  $800 \text{ cm}^3/\text{g} \cdot \text{mole}$ . The temperature will reach  $127^\circ\text{C}$ . What will the pressure (psi) be according to the Redlich-Kwong relation? Use *Unit Management*.

$$P_c = 48.2 \text{ atm}$$

$$T_c = 305.5 \text{ K}$$

### Keystrokes (SIZE $\geq$ 020)

**FIX** 2  
**XEQ** **ALPHA** KWONG **ALPHA**  
 Y **R/S**  
 305.5 **R/S**  
 K **R/S**  
 48.2 **R/S**  
 ATM **R/S**  
 1 **R/S**  
**R/S**  
 800 **R/S**  
 CM3 **R/S**  
 1 **R/S**  
 G\*MOLE **R/S**  
 127 **R/S**  
 C **R/S**  
**A**  
 PSI **R/S**

### Display

**UNT CNV? Y/N**  
**Tc=?**  
**UNITS Tc?**  
**Pc=?**  
**UNITS Pc?**  
**M WT=?**  
**P=?**  
**V=?**  
**UNITS V?**  
**N=?**  
**UNITS N?**  
**T=?**  
**UNITS T?**  
**"SELECT KEY:"**  
**P V N T**  
**UNITS P?**  
**P=533.27 PSI**

\* Press **R/S** if you are not using a printer.

**Example 4:**

264 grams of carbon dioxide gas (molecular weight 44) are held at a pressure of 50 atmospheres, and at a temperature of 441°F. What is the volume in liters? Use the Redlich-Kwong relation.

$$T_c = 304.2 \text{ K}$$

$$P_c = 72.9 \text{ atm}$$

**Keystrokes (SIZE  $\geq$  020)**

**XEQ** **ALPHA** KWONG **ALPHA**

Y **R/S**

304.2 **R/S**

K **R/S**

72.9 **R/S**

ATM **R/S**

44 **R/S**

50 **R/S**

ATM **R/S**

**R/S**

264 **R/S**

G **R/S**

441 **R/S**

F **R/S**

**B**

L **R/S**

How many grams could be contained at this temperature and pressure in 5 liters?

**R/S** \*

**R/S**

5 **R/S**

L **R/S**

**R/S**

**R/S**

**C**

G **R/S**

**Display**

**UNT CNV? Y/N**

**Tc=?**

**UNITS Tc?**

**Pc=?**

**UNITS Pc?**

**M WT=?**

**P=?**

**UNITS P?**

**V=?**

**M=?**

**UNITS M?**

**T=?**

**UNITS T?**

**"SELECT KEY:"**

**P V M T**

**UNITS V?**

**V=4.70 L**

**P=?**

**V=?**

**UNITS V?**

**M=?**

**T=?**

**"SELECT KEY:"**

**P V M T**

**UNITS M?**

**M=280.83 G**

\* Press **R/S** if you are not using a printer.

## POLYTROPIC PROCESSES FOR AN IDEAL GAS

This program solves interchangeably between pressure ratio, volume ratio, temperature ratio, and density ratio for polytropic processes involving ideal gases. These processes are defined by the relationship

$$PV^N = \text{constant}$$

which is shown graphically below.

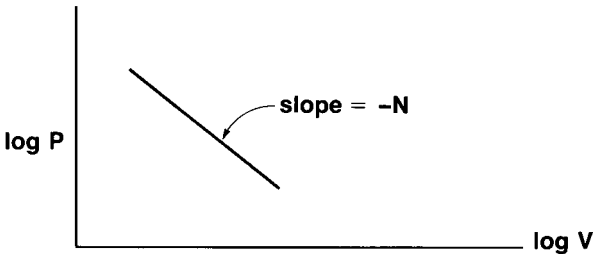

If the polytropic processes are reversible and adiabatic, they are called isentropic. Then the value used for  $N$  is  $k$ , the specific heat ratio for the gas.

### Equations:

$$\frac{P_2}{P_1} = \left(\frac{V_2}{V_1}\right)^{-N} = \left(\frac{T_2}{T_1}\right)^{\frac{N}{N-1}} = \left(\frac{D_2}{D_1}\right)^N$$

where:

$P_2/P_1$  is the final pressure divided by the initial pressure;

$V_2/V_1$  is the final volume divided by the initial volume;

$T_2/T_1$  is the final temperature divided by the initial temperature;

$D_2/D_1$  is the final density divided by the initial density;

$N$  is the polytropic constant.

				SIZE:003
STEP	INSTRUCTIONS	INPUT	FUNCTION	DISPLAY
1	Initialize program.		<b>XEQ</b> POLYTRP	N=?
2	Key in polytropic constant.	N	<b>R/S</b>	SELECT KEY: P V T D
3	Select the known input value: pressure ratio, volume ratio, temperature ratio, density ratio.		<b>A</b> <b>B</b> <b>C</b> <b>D</b>	P2/P1=? V2/V1=? T2/T1=? D2/D1=?
4	Input the known value and calculate all others.	VALUE	<b>R/S</b> <b>R/S</b> * <b>R/S</b> * <b>R/S</b> *	P2/P1= V2/V1= T2/T1= D2/D1=
5	For a new known value with the same N go to step 3. For a new value of N, go to step 1. *Press <b>R/S</b> if you are not using a printer.		<b>R/S</b> *	

Example:

An air compressor has a compression ratio ( $V_1/V_2$ ) of 8.5 to 1. The polytropic constant is 1.43. If the inlet air is at atmospheric pressure 14.7 psi, what is the outlet pressure? What is the final temperature if the inlet is 65°F?

Keystrokes (SIZE > 003)

Display

```

FIX 2
XEQ ALPHA POLYTRP ALPHA N=?
1.43 R/S SELECT KEY:
B P V T D
8.5 USER ** 1/X USER R/S V2/V1=?
R/S * P2/P1=21.33
R/S * V2/V1=0.12
R/S * T2/T1=2.51
14.7 ENTER 21.33 X D2/D1=8.50
313.55

```

The temperature ratio,  $T_2/T_1$  uses absolute temperatures:

```

65 ALPHA F ALPHA XEQ ALPHA
-SI ALPHA 291.49 (T1, K)
2.51 X 731.62 (T2, K)
XEQ ALPHA SI- ALPHA 857.25 (T2, F)

```

\* Press **R/S** if you are not using a printer.

\*\* Since the top row of keys has been auto-assigned as **A**, **B**, **C**, and **D**, you must go out of USER mode to use **1/X**.

## ISENTROPIC FLOW FOR IDEAL GASES

This program replaces isentropic flow tables for a specified heat ratio  $k$ .

The following values are correlated:

$M$  is the Mach number;

$T/T_0$  is the ratio of flow temperature  $T$  to stagnation or zero velocity temperature  $T_0$ ;

$P/P_0$  is the ratio of flow pressure  $P$  to stagnation pressure  $P_0$ ;

$D/D_0$  is the ratio of flow density  $D$  to stagnation density  $D_0$ ;

$a/a^*$  and  $A/A^*$  are the ratios of flow area  $A$  to the throat area  $A^*$  in converging-diverging passages.  $a/a^*$  refers to subsonic flow while  $A/A^*$  refers to supersonic flow.

### Equations:

$$T/T_0 = \frac{2}{2 + (k - 1) M^2}$$

$$P/P_0 = (T/T_0)^{k/(k - 1)}$$

$$D/D_0 = (T/T_0)^{1/(k - 1)}$$

$$a/a^* \text{ and } A/A^* = \frac{1}{M} \left[ \left( \frac{2}{k + 1} \right) \left( 1 + \frac{k - 1}{2} M^2 \right) \right]^{\frac{k + 1}{2(k - 1)}}$$

				SIZE: 008
STEP	INSTRUCTIONS	INPUT	FUNCTION	DISPLAY
1	Initialize program.		<b>XEQ</b> ISNFLOW	K=?
2	Key in specific heat ratio.	k	<b>R/S</b>	"SELECT KEY:" M T P D A,a
3	Select input: to input Mach number; to input temperature ratio; to input pressure ratio; to input density ratio; to input supersonic area ratio; to input subsonic area ratio.		<b>A</b> <b>B</b> <b>C</b> <b>D</b> <b>E</b> <b>E</b>	M=? T/T0=? P/P0=? D/D0=? A/A*=? a/a*=?
4	Key in selected value and compute all values:	VALUE	<b>R/S</b> <b>R/S</b> * <b>R/S</b> * <b>R/S</b> * <b>R/S</b> * <b>R/S</b> *	M= T/T0= P/P0= D/D0= A/A*= or a/a*= M T P D A,a
5	For a new input go to step 3. For a new case, go to step 1.  *Press <b>R/S</b> if you are not using a printer.			

**Example 1:**

A pilot is flying at Mach 0.93 and reads an air temperature of 15 degrees Celsius (288 K) on a thermometer that reads stagnation temperature  $T_0$ . What is the true temperature assuming that  $k = 1.38$ ?

**Keystrokes (SIZE ≥ 008)**

**FIX** 4  
**XEQ** **ALPHA** ISNFLOW **ALPHA**  
 1.38 **R/S**  
**A**  
 .93 **R/S**  
**R/S** \*  
**R/S** \*  
**R/S** \*  
**R/S** \*  
**R/S** \*  
 .8589 **ENTER** 288 **X**  
 273 **-**

**Display**

K=?  
 "SELECT KEY:"  
 M T P D A,a  
 M=?  
 M=0.9300  
 T/T0=0.8589  
 P/P0=0.5755  
 D/D0=0.6701  
 a/a\*=1.0043  
 M T P D A,a  
 247.3632 (K)  
 -25.6368 (°C)

If the same pilot reads a stagnation pressure  $P$  of 700 millimeters of mercury, what is the true air pressure?

.5755 **ENTER** 700 **x** **402.8500** (mm Hg)

### Example 2:

A converging, diverging passage has supersonic flow in the diverging section. At an area ratio  $A/A^*$  of 1.60, what are the isentropic flow ratios for temperature, pressure and density? What is the Mach number?  $k = 1.74$ .

### Keystrokes

**■** **FIX** 4  
**XEQ** **ALPHA** ISNFLOW **ALPHA**  
 1.74 **R/S**  
**E**  
 1.6 **R/S**  
**R/S** \*  
**R/S** \*  
**R/S** \*  
**R/S** \*  
**R/S** \*

### Display

**K=?**  
**"SELECT KEY:"**  
**M T P D A,a**  
**A/A\*=?**  
**M=2.1054**  
**T/T0=0.3788**  
**P/P0=0.1020**  
**D/D0=0.2693**  
**A/A\*=1.6000**  
**M T P D A,a**

## CONDUIT FLOW

This program solves for the average velocity or the pressure drop, of viscous incompressible flow in conduits. For round conduits the volumetric flow rate is also computed.

The program includes the *Unit Management System* which is explained in the front of this manual.

A special program feature allows automatic storage of the properties of water at room temperature. This option is selected by executing H20 instead of FLOW.

### Equations:

$$v^2 = \frac{\Delta P/\rho}{2\left(f \frac{L}{D} + \frac{K_T}{4}\right)}$$

For laminar flow ( $Re < 2300$ )

$$f = 16/Re$$

For turbulent flow ( $Re > 2300$ )

$$\frac{1}{\sqrt{f}} = 1.737 \ln \frac{D}{\epsilon} + 2.28 - 1.737 \ln \left( 4.67 \frac{D}{\epsilon Re \sqrt{f}} + 1 \right)$$

is solved by Newton's method.

$$\frac{1}{\sqrt{f_0}} = 1.737 \ln \frac{D}{\epsilon} + 2.28$$

is used as an initial guess in the iteration.

$$Q = v A$$

where:

Re is the Reynolds number, defined as  $\rho Dv/\mu$ .

D is the pipe diameter;

$\epsilon$  is the dimension of irregularities in the conduit surface (see table 2);

f is the Fanning friction factor for conduit flow;

$\Delta P$  is the pressure drop along the conduit;



$\rho$  is the density of the fluid;

$\mu$  is the viscosity of the fluid;

$L$  is the conduit length;

$v$  is the average fluid velocity;

$\Sigma K$  is the total of the applicable fitting coefficients in table 1;

$Q$  is the volumetric flow rate.

**Table 1**  
**Fitting Coefficients**

Fitting	K
Globe valve, wide open	7.5—10
Angle valve, wide open	3.8
Gate valve, wide open	0.15—0.19
Gate valve, $\frac{3}{4}$ open	0.85
Gate valve, $\frac{1}{2}$ open	4.4
Gate valve, $\frac{1}{4}$ open	20
90° elbow	0.4—0.9
Standard 45° elbow	0.35—0.42
Tee, through side outlet	1.5
Tee, straight through	.4
180° bend	1.6
Entrance to circular pipe	0.25—0.50
Sudden expansion	$(1 - A_{up}/A_{dn})^{2*}$
Acceleration from $v = 0$ to $v = v_{entrance}$	1.0

\* $A_{up}$  is the upstream area and  $A_{dn}$  is the downstream area.

**Table 2**  
**Surface Irregularities**

Material	$\epsilon$ (feet)	$\epsilon$ (meters)
Drawn or Smooth Tubing	$5.0 \times 10^{-6}$	$1.5 \times 10^{-6}$
Commercial Steel or Wrought Iron	$1.5 \times 10^{-4}$	$4.6 \times 10^{-5}$
Asphalted Cast Iron	$4.0 \times 10^{-4}$	$1.2 \times 10^{-4}$
Galvanized Iron	$5.0 \times 10^{-4}$	$1.5 \times 10^{-4}$
Cast Iron	$8.3 \times 10^{-4}$	$2.5 \times 10^{-4}$
Wood Stave	$6.0 \times 10^{-4}$ to $3.0 \times 10^{-3}$	$1.8 \times 10^{-4}$ to $9.1 \times 10^{-4}$
Concrete	$1.0 \times 10^{-3}$ to $1.0 \times 10^{-2}$	$3.0 \times 10^{-4}$ to $3.0 \times 10^{-3}$
Riveted Steel	$3.0 \times 10^{-3}$ to $3.0 \times 10^{-2}$	$9.1 \times 10^{-4}$ to $9.1 \times 10^{-3}$

**Reference:**

Welty, Wicks, Wilson, *Fundamentals of Momentum, Heat and Mass Transfer*, John Wiley and Sons, Inc., 1969.

**Remarks:**

If the conduit is not circular, an equivalent diameter may be calculated using the formula below:

$$D_{eq} = 4 \frac{\text{cross sectional area}}{\text{wetted perimeter}}$$

Values of  $Q$  generated using an equivalent diameter will be inaccurate. In such cases use:

$$Q = vA$$

where  $A$  is the section area and  $v$  is the average fluid velocity.

If  $2300 < Re < 4000$  flow is neither laminar nor turbulent. In this region, the correlation may yield meaningless results. The calculator will halt displaying "TRANSITION". Pressing **R/S** will cause computation to continue but results may have little or no physical significance.

You may wish to write your own routines similar to **H20** which automatically store fluid properties. Such routines should do the following:

1. Start with the steps:

```
LBL XYZ
18
XEQ SZ?
CLA
ASTO 01
ASTO 02
SF 00
CF 01
```

2. Continue with code which stores the viscosity in  $N \cdot s/m^2$  in register 16 and the density in  $kg/m^3$  in register 17.
3. Complete your program with:

```
GTO FLOW2
```

				SIZE: 018
STEP	INSTRUCTIONS	INPUT	FUNCTION	DISPLAY
1	Initialize program: For water at room temperature. For other substances.		<input type="checkbox"/> H2O <input type="checkbox"/> FLOW	IRREG=? UNT CNV? Y/N
2	For water skip to step 6.			
3	If you wish automatic conversions key "Y" otherwise key "N".	Y or N	<input type="checkbox"/>	VIS=?
4	Key in viscosity of fluid.	viscosity	<input type="checkbox"/>	DEN=?
5	Key in density of fluid.	density	<input type="checkbox"/>	IRREG=?
6	Key in height of conduit surface irregularities.	$\epsilon$	<input type="checkbox"/>	L=?
7	Key in length of conduit.	length	<input type="checkbox"/>	D=?
8	Key in equivalent diameter of conduit.	diameter	<input type="checkbox"/>	$\Sigma K$ =?
9	Key in sum of fitting coefficients.	$\Sigma K$	<input type="checkbox"/>	"SELECT KEY:" P V Q
10	If you know P, press <input type="checkbox"/> . If you know V, press <input type="checkbox"/> . If you know Q, press <input type="checkbox"/> .		<input type="checkbox"/> <input type="checkbox"/> <input type="checkbox"/>	P=? V=? Q=?†
11	Key in P, V, or Q† and calculate the remaining two variables.	P, V or Q	<input type="checkbox"/> <input type="checkbox"/> * <input type="checkbox"/> *	P= or V= V= or Q= VIS=?
12	For a totally new case, go to step 1. To change only selected inputs, go to step 4. For values that do not change, ignore the prompt and press <input type="checkbox"/> .  *Press <input type="checkbox"/> if you are not using a printer. †Q has no meaning if the conduit is not circular and flowing full.			

Example 1:

A heat exchanger has 20, 3 meter tube passes (60 m of pipe) with 180 degree bends connecting each pair of tubes (from table 1,  $K_T = 10 \times 1.6$ ). The fluid viscosity is  $9.3 \times 10^{-4} \text{N}\cdot\text{s}/\text{m}^2$  and the density is  $1000 \text{Kg}/\text{m}^3$ . The surface roughness is  $3 \times 10^{-4} \text{m}$  and the diameter is  $2.54 \times 10^{-2} \text{m}$ . If the flow rate is  $1.545 \times 10^{-3} \text{m}^3/\text{s}$ , what is the pressure loss?

Keystrokes (SIZE  $\geq$  018)

Display

**ENG** 3  
**XEQ** **ALPHA** FLOW **ALPHA**  
 N **R/S**  
 9.3 **EEX** **CHS** 4 **R/S**  
 1000 **R/S**  
 3 **EEX** **CHS** 4 **R/S**  
 60 **R/S**  
 2.54 **EEX** **CHS** 2 **R/S**  
 16 **R/S**

UNT CNV? Y/N

VIS=?

DEN=?

IRREG=?

L=?

D=?

$\Sigma K$ =?

"SELECT KEY:"

P V Q

Q=?

P=521.6E3

(N/m<sup>2</sup>)

**C**

1.545 **EEX** **CHS** 3 **R/S**

Example 2:

For the system shown, what is the volumetric flow rate? Use the unit conversion option and the **H20** routine for the properties of water.

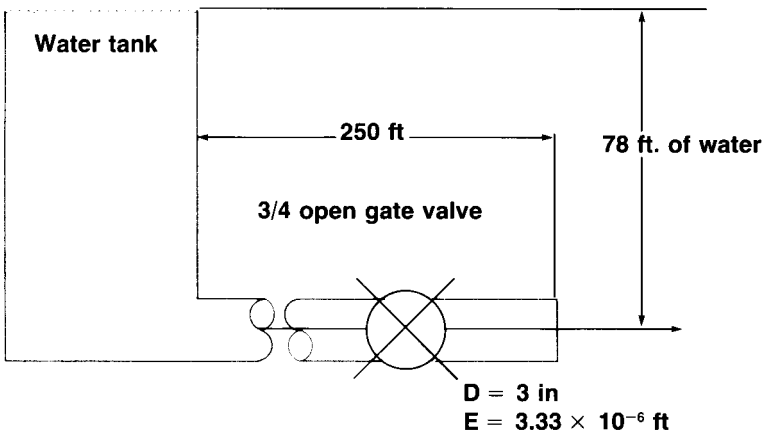

$$\begin{aligned}
 K_T &= K_0 + K_1 + K_2 \\
 &= 1 + .4 + 0.85 = 2.25
 \end{aligned}$$

Keystrokes (SIZE  $\geq$  018)

■ **FIX** 2

**XEQ** **ALPHA** H20 **ALPHA**

3.33 **EEX** **CHS** 6 **R/S**

FT **R/S**

250 **R/S**

FT **R/S**

3 **R/S**

IN **R/S**

2.25 **R/S**

**A**

78 **R/S**

FTH20 **R/S**

FT/S **R/S**

**R/S** \*

FT3/S **R/S**

## Display

*IRREG=?*

*UNITS IRREG?*

*L=?*

*UNITS L?*

*D=?*

*UNITS D?*

*$\Sigma K=?$*

*"SELECT KEY:"*

*P V Q*

*P=?*

*UNITS P?*

*UNITS V?*

*V=17.71 FT/S*

*UNITS Q?*

*Q=0.87 FT3/S*

\*Press **R/S** if you are not using a printer.

## ENERGY EQUATION FOR STEADY FLOW

This program uses a control volume approach to solve a wide variety of problems involving fluid flow. Differences in height, pressure, and velocity between the entrance and exit of the control volume are converted to flow energy. Power may also be supplied or extracted between the entrance and exit.

The *Unit Management System* is automatically invoked by this program. The *Unit Management System* is explained in the front of this manual.

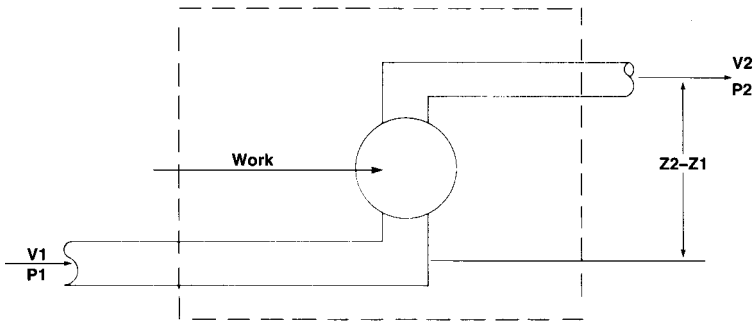

### Equations:

$$PWRIN = \dot{m} \left[ \left( \frac{V_2^2 - V_1^2}{2} \right) + g(Z_2 - Z_1) + \frac{(P_2 - P_1)}{\rho} \right]$$

where:

PWRIN is the power supplied within the control volume;

$\dot{m}$  is the mass flow rate;

Q is the volumetric flow rate;

$V_2$  and  $V_1$  are the exit and entrance fluid velocities;

g is the acceleration of gravity.

$Z_2$  and  $Z_1$  are the exit and entrance heights above a reference datum;

$P_2$  and  $P_1$  are the exit and entrance pressures;

$\rho$  is the fluid density.

				SIZE: 012
STEP	INSTRUCTIONS	INPUT	FUNCTION	DISPLAY
1	Initialize program.		<b>XEQ</b> ENERGY	DENS=?
2	Key in fluid density.	$\rho$	<b>R/S</b>	MDOT=?
3a	Key in mass flow rate.	$\dot{m}$	<b>R/S</b>	V1=?
3b	If you know volumetric flow rate, instead of mass flow rate press <b>R/S</b> to get the prompt, then key in volumetric flow rate.		<b>R/S</b>	Q=?
		Q	<b>R/S</b>	V1=?
4	Key in initial fluid velocity.	V1	<b>R/S</b>	V2=?
5	Key in the final fluid velocity.	V2	<b>R/S</b>	Z2-Z1=?
6	Key in height difference.	Z2-Z1	<b>R/S</b>	P2-P1=?
7	Key in pressure difference. (The next step is skipped automatically if $m=0$ .)	P2-P1	<b>R/S</b>	PWRIN=?
8	Key in input power.	PWRIN	<b>R/S</b>	SELECT KEY: V Z P PWR
9	Calculate the unknown value: velocity, change in height, change in pressure, or power input.		<b>A</b> <b>B</b> <b>C</b> <b>D</b>	V1= or V2= dZ= dP= PWRIN=
10	For a new case go to step 1. This clears V1, V2, Z2-Z1, P2-P1 and PWRIN but leaves $\rho$ and $m$ unchanged. To modify the existing case, go to step 4. You do not need to key in unchanged values. Ignore the prompt and press <b>R/S</b> .  *Press <b>R/S</b> if you are not using a printer.		<b>R/S</b> *	V1=?

Example 1:

A water tower is 100 feet high. If 10,000 pounds of water are pumped to the top of the tower every hour, at a velocity of 20 ft/s, with a frictional pressure drop of 2 psi, how much horsepower is needed at the pump? The density of water is 62.4 lbm/ft<sup>3</sup>.

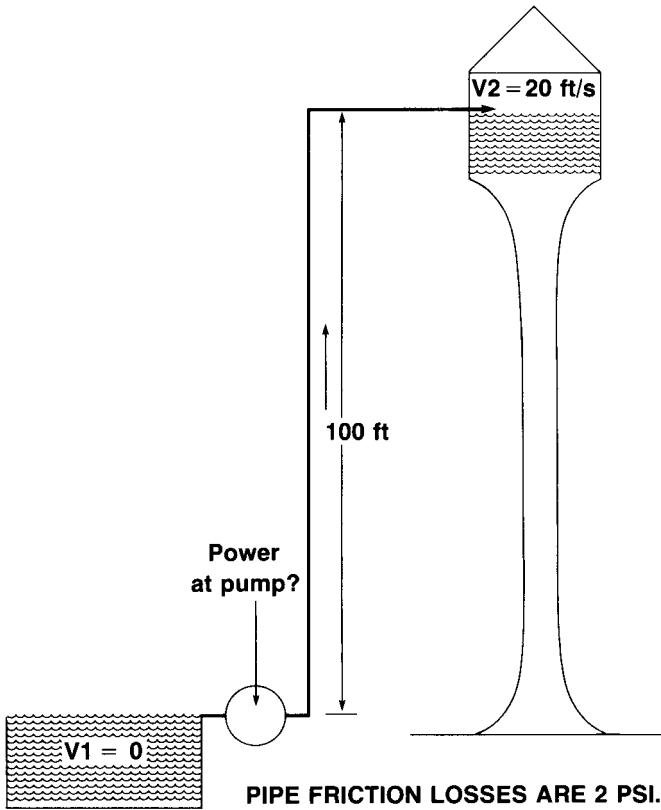

Keystrokes (SIZE ≥ 012)

FIX 2  
 XEQ  ALPHA ENERGY  ALPHA  
 62.4  R/S  
 LBM/FT3  R/S  
 10000  R/S  
 LBM/HR  R/S

Display

DENS=?  
 UNITS DENS?  
 MDOT=?  
 UNITS MDOT?  
 V1=?



Since  $V1 = 0$  and is automatically set to zero on initialization, skip the input.

**R/S**  
 20 **R/S**  
 FT/S **R/S**  
 100 **R/S**  
 FT **R/S**  
 2 **R/S**  
 PSI **R/S**

**V2=?**  
**UNITS V2?**  
**Z2-Z1=?**  
**UNITS Z2-Z1?**  
**P2-P1=?**  
**UNITS P2-P1?**  
**PWRIN=?**

Since this is the unknown, skip the input.

**R/S**  
  
**D**  
 HP **R/S**

**SELECT KEY:**  
**V Z P PWR**  
**UNITS PWRIN?**  
**PWRIN=0.56HP**

**Example 2:**

An incompressible fluid ( $\rho = 735 \text{ kg/m}^3$ ) flows through the converging passage shown below. At point 1 the velocity is 3 m/s and at point 2 the velocity is 15 m/s. The elevation difference between points 1 and 2 is 3.7 meters. Assuming frictionless flow, what is the static pressure difference between points 1 and 2? The flow rate is  $20 \text{ m}^3/\text{s}$ . Since all values are given in SI units you may ignore all unit prompts by simply pressing **[R/S]**.

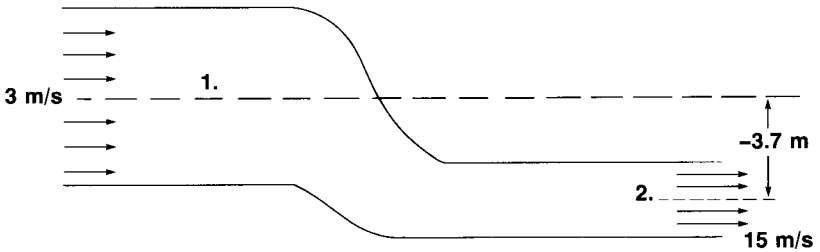

**Keystrokes (SIZE > 012)**

**[FIX]** 2  
**[XEQ]** **[ALPHA]** ENERGY **[ALPHA]**  
 735 **[R/S]**  
**[R/S]**  
**[R/S]**  
 20 **[R/S]**  
**[R/S]**  
 3 **[R/S]**  
**[R/S]**  
 15 **[R/S]**  
**[R/S]**  
 3.7 **[CHS]** **[R/S]**  
**[R/S]**  
**[R/S]**  
**[R/S]**  
**[C]**  
**[R/S]**

**Display**

**DENS=?**  
**UNITS DENS?**  
**MDOT=?**  
**Q=?**  
**UNITS Q?**  
**V1=?**  
**UNITS V1?**  
**V2=?**  
**UNITS V2?**  
**Z2-Z1=?**  
**UNITS Z2-Z1?**  
**P2-P1=?**  
**PWRIN=?**  
**SELECT KEY:**  
**V Z P PWR**  
**UNITS P2-P1?**  
**P2-P1=-52,710.82 PA**

## HEAT EXCHANGERS

This program allows analysis of counterflow, parallel flow, parallel-counterflow, and crossflow heat exchangers.

The *Unit Management System* may be used through this program. The *Unit Management System* is explained in the front of this manual.

Figure 1:

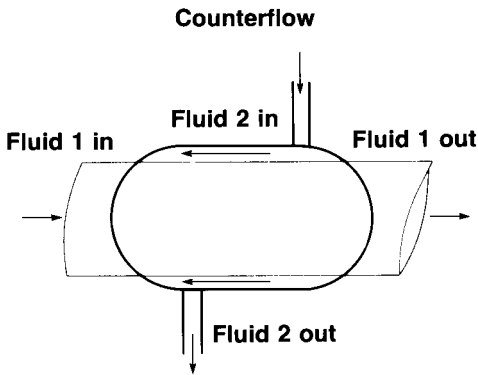

Figure 2:

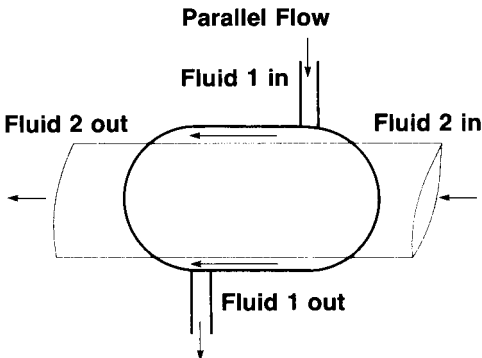
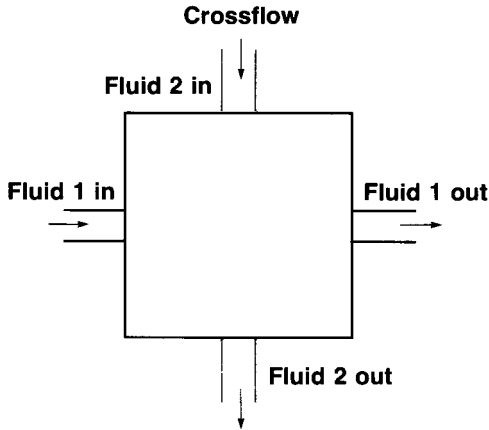
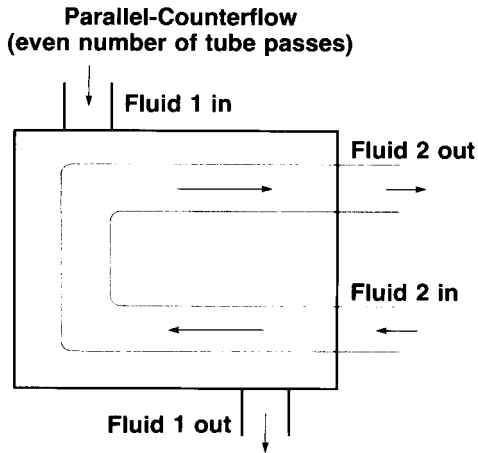

Figure 3:



**Equations:**

Heat exchanger effectiveness  $E$  is the ratio of actual heat transfer to maximum possible heat transfer.

$$E = \frac{Q}{C_{\min} (T_{\text{hin}} - T_{\text{cin}})} = \frac{C_h (T_{\text{hin}} - T_{\text{ho}})}{C_{\min} (T_{\text{hin}} - T_{\text{cin}})} = \frac{C_c (T_{\text{co}} - T_{\text{cin}})}{C_{\min} (T_{\text{hin}} - T_{\text{cin}})}$$

where:

$Q$  is the actual heat transfer;

$T_{\text{hin}}$  and  $T_{\text{cin}}$  are the inlet temperatures of the hot and cold fluids, respectively;

$T_{\text{ho}}$  and  $T_{\text{co}}$  are the outlet temperatures of the hot and cold fluids, respectively;

$C_h$  and  $C_c$  are the heat capacities of the hot and cold fluids, respectively, e.g.,  $C_h = m_h \times c_{ph}$ , where  $m_h$  is the flow rate and  $c_{ph}$  is the specific heat capacity of the hot fluid;

$C_{\min}$  and  $C_{\max}$  are the smaller and larger values of  $C_h$  and  $C_c$ .

Effectiveness can be related to the product of the surface area ( $A$ ) of the heat exchanger and the overall heat transfer coefficient ( $U$ ) for specific geometries. The product is designated  $AU$ . The geometries considered in this pac have the following correlations:

Counterflow (see figure 1)

$$E = \frac{1 - e^{-\frac{AU}{C_{\min}} \left(1 - \frac{C_{\min}}{C_{\max}}\right)}}{1 - (C_{\min}/C_{\max}) e^{-\frac{AU}{C_{\min}} \left(1 - \frac{C_{\min}}{C_{\max}}\right)}}$$

For  $C_{\min}/C_{\max} = 1$

$$E = \frac{AU/C_{\min}}{1 + AU/C_{\min}}$$

Parallel Flow (see figure 2)

$$E = \frac{1 - e^{-\frac{AU}{C_{\min}} (1 + C_{\min}/C_{\max})}}{1 + C_{\min}/C_{\max}}$$

For  $C_{\min}/C_{\max} = 0$ ,  $C_{\min}$  is set to 1.

Parallel-Counterflow (well mixed with an even number of tube passes; see

figure 3)

$$E = \frac{2}{\left(1 + \frac{C_{\min}}{C_{\max}}\right) + \sqrt{1 + \left(\frac{C_{\min}}{C_{\max}}\right)^2} \left[\frac{1 + e^{-x}}{1 - e^{-x}}\right]}$$

where:

$$x = \frac{AU}{C_{\min}} \sqrt{1 + \left(\frac{C_{\min}}{C_{\max}}\right)^2}$$

## 42 Heat Exchangers

Crossflow (both fluids unmixed; see figure 4)

No exact expression exists for this case, but the following is a very good approximation. Note that it cannot be stated explicitly in terms of AU and thus requires an iterative solution.

$$E = 1 - e \left( e^{\left( -\frac{AU}{C_{\min}} \frac{C_{\min}}{C_{\max}} y \right)} - 1 \right) \left( \frac{C_{\max}}{C_{\min}} \frac{1}{y} \right)$$

where:

$$y = \left[ \frac{C_{\min}}{AU} \right]^{0.22}$$

### References:

Kays, W.M. and A.L. London, *Compact Heat Exchangers*, National Press, 1955.

Eckert and Drake, *Heat and Mass Transfer*, McGraw-Hill.

### Remarks:

The solution for AU in the crossflow configuration takes significantly longer than other solutions because of the iterative technique required.

The program must be allowed to solve for all values (AU, Q,  $T_{co}$ , and E). It is quite possible for the heat balance equations to yield physically meaningless solutions for a particular configuration. However, the message "2ND LAW ERR" will be displayed if the 2<sup>nd</sup> law of thermodynamics has been violated during the calculation of AU or Q.

This program is organized into five routines. The first routine performs heat balance calculations and acts as a controller for the four configuration routines. Each configuration routine has two sections that calculate AU and E for that heat exchanger. The controller executes the section of the desired configuration routine based on the configuration you select. This technique allows you to create your own configuration routines that can be executed by the controller.

A sample routine for a configuration called BOIL must be in the following format:

```

          LBL ABOIL
          .
          .
          .
          (calculates AU for this configuration)
          .
          .
          .
          RTN
          LBL EBOIL
          .
          .
          .
          (calculates E for this configuration)
          .
          .
          .
          END
  
```

BOIL must be one to five ALPHA characters. It must be preceded by an A and used to label the AU calculation section, and preceded by an E and used to label the E calculation section. When the program asks you to spell the configuration, you would key in BOIL instead of the configuration names that are included in the pac program.

For cases where the inlet and outlet temperatures of one of the fluids are equal (change of phase), use zero for the heat capacity of that fluid.

				SIZE: 023
STEP	INSTRUCTIONS	INPUT	FUNCTION	DISPLAY
1	Initialize program.		<input type="checkbox"/> XEQ HEATEX	TC IN=?
2	Input inlet temperature of cold fluid.	$T_{cin}$	<input type="checkbox"/> R/S	TH IN=?
3	Input inlet temperature of hot fluid.	$T_{hin}$	<input type="checkbox"/> R/S	MC=?
4	Input mass flow rate of cold fluid.	$m_c$	<input type="checkbox"/> R/S	MH=?
5	Input mass flow rate of hot fluid.	$m_h$	<input type="checkbox"/> R/S	CPC=?
6	Input specific heat of cold fluid.	$C_{pc}$	<input type="checkbox"/> R/S	CPH=?

STEP	INSTRUCTIONS	INPUT	FUNCTION	DISPLAY
7	Input specific heat of hot fluid.	$C_{ph}$	<input type="button" value="R/S"/>	SPELL CNFG:
8	Spell desired configuration:  counterflow or parallel flow or parallel-counterflow or crossflow or a configuration you create.	CNT PAR PRC CRS	<input type="button" value="R/S"/> <input type="button" value="R/S"/> <input type="button" value="R/S"/> <input type="button" value="R/S"/>	PRC, CNT, PAR or CRS  SELECT KEY: E AU Q TC TH
9	Select the known value: heat exchanger effectiveness area-heat transfer coefficient product heat transfer outlet temperature of cold fluid outlet temperature of hot fluid		<input type="button" value="A"/>  <input type="button" value="B"/> <input type="button" value="C"/> <input type="button" value="D"/> <input type="button" value="E"/>	E=?  AU=? Q=? TCO=? THO=?
10	Input the known value.	E AU Q TCO THO	<input type="button" value="R/S"/> <input type="button" value="R/S"/> <input type="button" value="R/S"/> <input type="button" value="R/S"/> <input type="button" value="R/S"/>	
11	The four variables other than the one you input will be output. The output order will vary depending on which value was input. If the 2 <sup>nd</sup> law of thermodynamics is violated, the message "2ND LAW ERR" will be displayed.		<input type="button" value="R/S"/> * <input type="button" value="R/S"/> * <input type="button" value="R/S"/> * <input type="button" value="R/S"/> *	E= AU= Q= TCO= THO=
12	For a new configuration, go to step 8. For a new problem, go to step 1. It is not necessary to key in any values which do not change. Ignore the prompts and press <input type="button" value="R/S"/> .  *Press <input type="button" value="R/S"/> if you do not have a printer.			



## Example 1:

Water ( $c_p = 1 \text{ Btu/lbm } ^\circ\text{F}$ ) is used to cool an oil ( $c_p = .53 \text{ Btu/lbm } ^\circ\text{F}$ ) from  $200^\circ\text{F}$  to  $110^\circ\text{F}$ . The water flow rate is 20,000 pounds per hour while the oil flows at 37,000 pounds per hour. If the water inlet temperature is  $55^\circ\text{F}$  and  $U$  is  $25 \text{ Btu/hr} \cdot \text{ft}^2 \cdot ^\circ\text{F}$  for the heat exchangers being considered, what are the area requirements for counterflow, parallel flow, parallel-counterflow, and crossflow? Use the *Unit Management System*.

## Knowns:

$$T_{\text{cin}} = 55 \text{ F}$$

$$T_{\text{hin}} = 200 \text{ F}$$

$$m_c = 20,000 \text{ lbm/hr}$$

$$m_h = 37,000 \text{ lbm/hr}$$

$$c_{pc} = 1 \text{ Btu/lbm } ^\circ\text{F}$$

$$c_{ph} = 0.53 \text{ Btu/lbm } ^\circ\text{F}$$

$$T_{\text{ho}} = 110 \text{ F}$$

$$U = 25 \text{ Btu/hr} \cdot \text{ft}^2 \cdot ^\circ\text{F}$$

## Keystrokes (SIZE &gt; 023)

[ENG] 2  
 [XEQ] [ALPHA] HEATEX [ALPHA]  
 Y [R/S]  
 55 [R/S]  
 F [R/S]  
 200 [R/S]  
 F [R/S]  
 20000 [R/S]  
 LBM/HR [R/S]  
 37000 [R/S]  
 LBM/HR [R/S]  
 1 [R/S]  
 BTU/LBM\*F [R/S]  
 .53 [R/S]  
 BTU/LBM\*F [R/S]

Select counterflow configuration.

CNT [R/S]

[E]  
 110 [R/S]  
 F [R/S]  
 [R/S] \*

## Display

UNIT CNV? Y/N  
 TC IN=?  
 UNITS TC IN?  
 TH IN=?  
 UNITS TH IN?  
 MC=?  
 UNITS MC?  
 MH=?  
 UNITS MH?  
 CPC=?  
 UNITS CPC?  
 CPH=?  
 UNITS CPH?  
 SPELL CNFG:  
 CNT,PAR,PRC,CRS

SELECT KEY:  
 E AU Q TC TH  
 THO=?  
 UNITS THO?  
 E= 621.E-3  
 UNITS AU?

BTU/HR\*F **R/S****R/S** \*BTU/HR **R/S****R/S** \*F **R/S****R/S** \*

Select parallel flow configuration.

PAR **R/S****AU=31.6E3 BTU/HR\*F****UNITS Q?****Q=1.76E6 BTU/HR****UNITS TCO?****TCO=143.E0 F****CNT,PAR,PRC,CRS****SELECT KEY:****E AU Q TC TH**

Use the calculated effectiveness since it is the same for all configurations.

**A**.621 **R/S****R/S****E=?****2ND LAW ERR****CNT,PAR,PRC,CRS**

Select parallel-counterflow configuration.

PRC **R/S****SELECT KEY:****E AU Q TC TH****A**.621 **R/S****R/S****E=?****2ND LAW ERR****CNT,PAR,PRC,CRS**

Select crossflow configuration.

CRS **R/S****SELECT KEY:****E AU Q TC TH****A**.621 **R/S**BTU/HR\*F **R/S****R/S** \*BTU/HR **R/S****R/S** \*F **R/S****E=?****UNITS AU?****AU=39.4E3 BTU/HR\*F****UNITS Q?****Q=1.77E6 BTU/HR****UNITS TCO?****TCO=143.E0 F****R/S** \*F **R/S****R/S** \***UNITS THO?****THO=110.E0 F****CNT,PAR,PRC,CRS**

Go out of ALPHA mode to calculate areas.

**ALPHA** 31.6 **EEX** **ENTER** 25 **+****1.26 03**(CNT area, ft<sup>2</sup>)39.4 **EEX** 3 **ENTER** 25 **+****1.58 03**(CRS area, ft<sup>2</sup>)\*Press **R/S** if you do not have a printer.

**Example 2:**

If a counterflow exchanger with an area of 1000 ft<sup>2</sup> and an overall heat transfer coefficient of 27 Btu/hr · ft<sup>2</sup> · °F is available, how close will the outlet temperature of the oil be to 110 F? What will the total heat transfer and outlet water temperature be? All unspecified values remain the same as example 1.

**Keystrokes****Display**

Go back to ALPHA mode to continue.

**ALPHA**

**CTN,PAR,PRC,CRS**

CNT **R/S**

**SELECT KEY:**

**E AU Q TC TH**

**B**

**AU=?**

27 **ENTER\*** 1000 **X** **R/S**

**UNITS AU?**

BTU/HR\*F **R/S**

**UNITS Q?**

BTU/HR

**Q=1.66E6 BTU/HR**

**R/S** \*

**UNITS TCO?**

F **R/S**

**TCO=138.E0 F**

**R/S** \*

**UNITS THO?**

F **R/S**

**THO=116.E0 F**

**R/S** \*

**E=583.E-3**

\*Press **R/S** if you do not have a printer.

## BLACK BODY THERMAL RADIATION

Bodies with finite temperatures emit thermal radiation. The higher the absolute temperature, the more thermal radiation emitted. Bodies which emit the maximum possible amount of energy at every wavelength for a specified temperature are said to be black bodies. While black bodies do not actually exist in nature, many surfaces may be assumed to be black for engineering considerations.

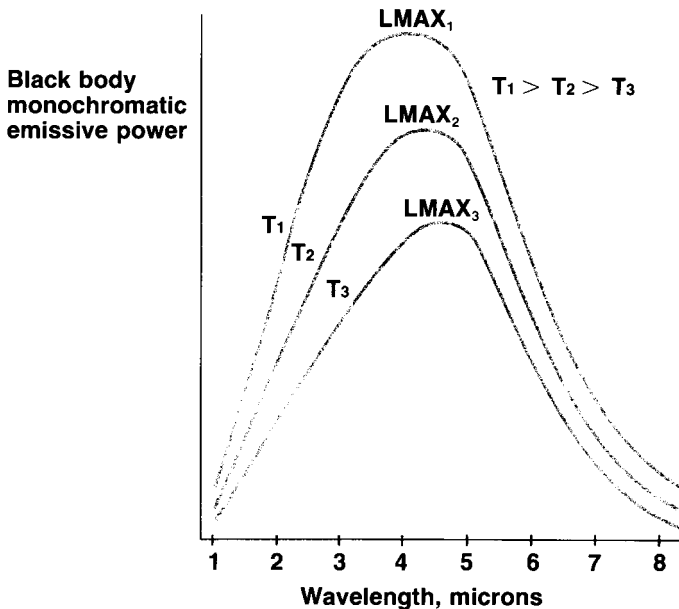

Figure 1.

**Equations:**

$$L_{MAX} = c_3/T$$

$$E_b = \sigma T^4$$

$$E_b L = \frac{2\pi c_1}{L^5(e^{c_2/LT} - 1)}$$

$$E_{b12} = \int_{L_1}^{L_2} \frac{2\pi c_1}{L^5(e^{c_2/LT} - 1)} dL$$

where:

LMAX is the wavelength of maximum emissivity;

T is the absolute temperature;

Eb is the total emissive power;

EbL is the emissive power at L;

L1 and L2 are the upper and lower wavelengths;

Eb12 is the total emissive power for all wavelengths between L1 and L2.

$$c_1 = 5.9544 \times 10^{-17} \quad \text{W} \cdot \text{m}^2$$

$$c_2 = 1.4388 \times 10^{-2} \quad \text{m} \cdot \text{K}$$

$$c_3 = 2.8978 \times 10^{-3} \quad \text{m} \cdot \text{K}$$

$$\sigma = 5.6693 \times 10^{-8} \quad \text{W}/(\text{m}^2 \cdot \text{K})$$

**Reference:**

Siegel, Robert and John R. Howell, *Thermal Radiation Heat Transfer*, Volume 1, National Aeronautics and Space Administration, 1968.

				SIZE: 020
STEP	INSTRUCTIONS	INPUT	FUNCTION	DISPLAY
1	Initialize program.		<input type="checkbox"/> XEQ	UNITS E?
2	Key in units of energy (not units of power).	UNITS E	<input type="checkbox"/> R/S	UNITS W V L?
3	Key in units of wavelength.	UNITS WVL	<input type="checkbox"/> R/S	UNITS AREA?
4	Key in units of area.	UNITS AREA	<input type="checkbox"/> R/S	UNITS TIME?
5	Key in units of time.	UNITS TIME	<input type="checkbox"/> R/S	T=?
6	Key in temperature.	T	<input type="checkbox"/> R/S	UNITS T?
7	Key in units of temperature and calculate total emissive power,	UNITS T	<input type="checkbox"/> R/S <input type="checkbox"/> R/S *	Eb= UNITS Eb
	and wavelength of maximum emissivity.		<input type="checkbox"/> R/S * <input type="checkbox"/> R/S *	LMAX= L1=?
8	Key in lower limit of integration and calculate the emissive power at that wavelength.	L1	<input type="checkbox"/> R/S <input type="checkbox"/> R/S * <input type="checkbox"/> R/S *	EbL= UNITS EbL L2=?

STEP	INSTRUCTIONS	INPUT	FUNCTION	DISPLAY
9	Key in upper limit of integration and calculate the emissive power at that wavelength,  and the total emissive power between L1 and L2.  *Press <b>R/S</b> if you are not using a printer.	L2	<b>R/S</b> <b>R/S</b> *  <b>R/S</b> * <b>R/S</b> * <b>R/S</b> *	EbL= UNITS EbL  Eb12= UNITS Eb12 T=?
10	For a new case with the same units go to step 6. For new units go to step 1. Any values which remain unchanged need not be keyed in. Ignore the prompt and press <b>R/S</b> .			

**Example:**

What percentage of the radiant output of a lamp is in the visible range (0.4 to 0.7 microns) if the filament of the lamp is assumed to be a black body at 2200°C? What is the percentage at 2300°C? What is the ratio of light for these two temperatures?

**Keystrokes (SIZE ≥ 020)**

**END** 3  
**XEQ** **ALPHA** BLKBODY **ALPHA**  
**J** **R/S**  
**MIC** **R/S**  
**CM2** **R/S**  
**S** **R/S**  
**2200** **R/S**  
**C** **R/S**  
**R/S** \*  
**R/S** \*  
**R/S** \*  
**.4** **R/S**  
**R/S** \*  
**R/S** \*  
**.7** **R/S**

**Display**

**UNITS E?**  
**UNITS WV L?**  
**UNITS AREA?**  
**UNITS TIME?**  
**T=?**  
**UNITS T?**  
**Eb=212.1E0**  
**J/S\*CM2**  
**LMAX=1.172E0 MIC**  
**L1=?**  
**EbL=1.763E0**  
**J/S\*CM2\*MIC**  
**L2=?**  
**EbL=54.73E0**

<b>R/S</b> *	<b><math>J/S \cdot CM^2 \cdot MIC</math></b>
<b>R/S</b> *	<b><math>E_{b12} = 6.661E0</math></b>
<b>R/S</b> *	<b><math>J/S \cdot CM^2</math></b>
<b>R/S</b> *	<b><math>T = ?</math></b>
2300 <b>R/S</b>	<b>UNITS T?</b>
<b>C</b> <b>R/S</b>	<b><math>E_b = 248.5E0</math></b>
<b>R/S</b> *	<b><math>J/S \cdot CM^2</math></b>
<b>R/S</b> *	<b><math>L_{MAX} = 1.126E0 MIC</math></b>
<b>R/S</b> *	<b><math>L_1 = ?</math></b>
<b>R/S</b>	<b><math>L_2 = ?</math></b>
<b>R/S</b> *	<b><math>E_{b12} = 9.702E0</math></b>
<b>R/S</b>	<b><math>J/S \cdot CM^2</math></b>

To find the percentage, divide the emissive power in the visible range by the total power.

at 2200°C:

6.662 **ENTER** 212.1 **+** 100 **x** **3.141 00** (%)

at 2300°C:

9.702 **ENTER** 248.5 **+** 100 **x** **3.904 00** (%)

To find the ratio of power at 2200°C to that at 2300°C divide the visible range powers.

6.662 **ENTER** 9.702 **+** **686.7 -03**

APPENDIX A  
PROGRAM DATA

Program	# Regs. to Copy	Data Registers	Flags	Display Format	Subprograms Called
Equations of State	61	00 STORAGE INDEX 01 UNIT CONVERSION 02 UNIT CONVERSION 03 $T_c$ 04 $P_c$ 05 R 06 M Wt 07 P 08 V 09 M or N 10 T 11 "M" or "N" 12 INDIRECT CONTROL 13 R/(MWt) 14 NR 15 a 16 b 17 a $T^{1/2}$ 18 (V+b) 19 (V-b)	00 Unit conversion 01 Ignore flag 00 02 Kwong 03 Input 04 Mass basis 05 Do a,b SUB. 21 Stop on output		UNIT? INPUT OUTPUT KEY
Polytropic Processes for an Ideal Gas	23	00 $P_2/P_1$ 01 N 02 $V_2/V_1$	21 Stop on output		SZ? KEY OUTPUT



Isentropic Flow for an Ideal Gas	40	00 M <sup>2</sup> 01 K 02 K-1 03 1/K-1 04 USED 05 A/A*, a/a* 06 USED	21 Stop on output	SZ? KEY INPUT OUTPUT
Conduit Flow	67	00 STORAGE INDEX 01 UNIT CONVERSION 02 UNIT CONVERSION 03 ROUGHNESS 04 LENGTH 05 DIAMETER 06 Σ FITTINGS 07 P 08 V 09 μ/ρ 10 D/ε 11 1.737 12 1/√f <sub>0</sub> 13 1/√f <sub>0</sub> 14 Re 15 V 16 Viscosity 17 Density	00 Unit conversion 01 Ignore 00 22 Data input 21 Stop on print	UNIT? INPUT OUTPUT KEY

Energy Equation for Steady Flow	41	00 STORAGE INDEX 01 UNIT CONVERSION 02 UNIT CONVERSION 03 g 04 DENSITY 05 MASS FLOW RATE 06 V1 07 V2 08 Z2- Z1 09 P2- P1 10 PWRIN 11 $\Sigma$ ENERGY	00 Unit conversion 21 Stop on input	UNIT? INPUT OUTPUT KEY
Heat Exchangers	108	00 STORAGE INDEX 01 UNIT CONVERSION 02 UNIT CONVERSION 03 TC IN 04 TH IN 05 C <sub>c</sub> 06 C <sub>H</sub> 07 C <sub>min</sub> 08 C <sub>max</sub> 09 C <sub>min</sub> /C <sub>max</sub> 10 E 11 AU 12 Q 13 TC OUT 14 TH OUT 15 MC	00 Unit conversion 01 Ignore 00 02 Stop after THO 03 Stop after E 04 Stop after AU 05 Stop after Q 06 Stop after TCO 21 Stop on output 23 Alpha input? 55 Printer connected	UNIT? INPUT OUTPUT KEY AO EO ACNT ECNT APAR EPAR APRC EPRC ACRS ECRS

- 16 MH
- 17 C<sub>pc</sub>
- 18 C<sub>ph</sub>
- 19 AU<sub>i-1</sub>
- 20 F (AU<sub>i</sub>)
- 21 F (AU<sub>i-1</sub>)

22 NAME CONFIGURATION

Black Body Thermal  
Radiation

00 Unit conversion  
21 Stop on output

SZ?  
INPUT  
OUTPUT  
Ebl

00 STORAGE INDEX

- 03 T
- 06 1/L
- 07 KC<sub>2</sub>/T
- 08 L<sub>1</sub>
- 09 L<sub>2</sub>
- 12 C<sub>1</sub>
- 13 C<sub>2</sub>
- 14 C<sub>3</sub>
- 15 σ
- 16 UNITS E
- 17 UNITS WV L
- 18 UNITS AREA
- 19 UNITS TIME



**1000 N.E. Circle Blvd., Corvallis, OR 97330**

**For additional sales and service information contact your  
local Hewlett-Packard Sales Office or call 800/648-4711.  
(In Nevada call 800/992-5710.)**