

HEWLETT-PACKARD

HP-41C

STRESS
ANALYSIS PAC

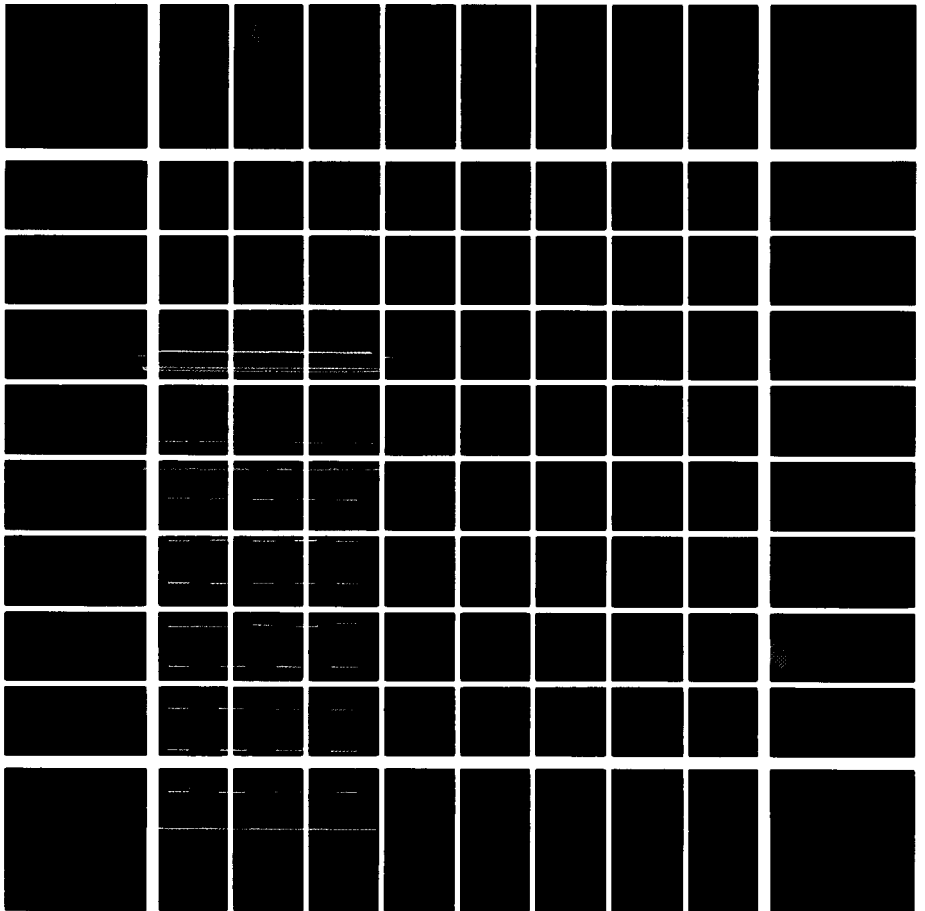

NOTICE

The program material contained herein is supplied without representation or warranty of any kind. Hewlett-Packard Company therefore assumes no responsibility and shall have no liability, consequential or otherwise, of any kind arising from the use of this program material or any part thereof.

INTRODUCTION

The HP-41C Stress Analysis Pac provides ready solutions for beam, cross section, column, fatigue, stress state and vector problems.

Each program in this pac is represented by one program in the Application Module and a section in this manual.

The manual provides a description of each program, a set of instructions for using each program, and one or more example problems, each of which includes a list of the keystrokes required for its solution.

Before plugging in your Application Module, **turn your calculator off**, and be sure you understand the section *Inserting and Removing Application Modules*. Before using a particular program, take a few minutes to read *Format of User Instructions* and *A Word About Program Usage*.

You should first familiarize yourself with a program by running it once or twice while following the complete User Instructions in the manual. Thereafter, the program's prompting or the mnemonics on the overlays should provide the necessary instructions, including which variables are to be input, which keys are to be pressed, and which values will be output.

We hope this pac will assist you in the solution of numerous problems in your discipline. We would appreciate knowing your reactions to the programs, and to this end we have provided a questionnaire inside the front cover of this manual. Would you please take a few minutes to give us your comments on these programs? It is from your comments that we learn how to increase the usefulness of our programs.

CONTENTS

Introduction	1
Contents	2
Inserting and Removing Application Modules	3
Format of User Instructions	5
A Word About Program Usage	6
Section Properties	8
Computes the moments of inertia for polygonal sections.	
Beams	18
Computes and/or plots deflection, slope, moment and shear for simple, cantilever, fixed, and propped cantilever beams.	
Simply Supported Continuous Beams	30
Computes internal bending moments at intermediate supports for continuous beams.	
Columns	40
Computes the axial compressive working load for columns.	
Mohr Circle Analysis	44
Given a stress configuration and orientation, computes principal stresses and/or the stress configuration for any orientation.	
Strain Gage Data Reduction	48
Reduced strains from rectangular and delta strain gages to principal strains and principal stresses.	
Soderberg's Equation for Fatigue	52
Calculates the sixth variable from the other five variable of Soderberg's equation.	
RPN Vector Calculator	55
Converts the HP-41C to a four high vector stack. Functions include plus, minus, cross product, dot product, X exchange Y roll down, roll up, last X, store, recall, and change sign.	
Appendix A—Program Data	59

INSERTING AND REMOVING APPLICATION MODULES

Before you insert an Application Module for the first time, familiarize yourself with the following information.

Up to four Application Modules can be plugged into the ports on the HP-41C. While plugged in, the names of all programs contained in the Module can be displayed by pressing  **CATALOG** 2.

CAUTION

Always turn the HP-41C off before inserting or removing any plug-in extension or accessories. Failure to turn the HP-41C off could damage both the calculator and the accessory.

To insert Application Modules:

1. Turn the HP-41C off! Failure to turn the calculator off could damage both the Module and the calculator.

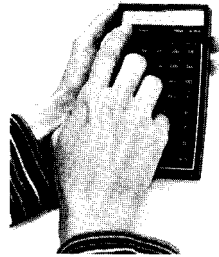

2. Remove the port covers. Remember to save the port covers; they should be inserted into the empty ports when no extensions are inserted.

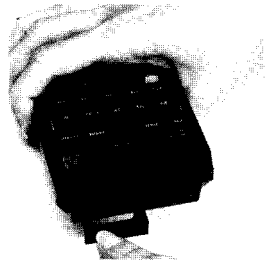

3. Insert the Application Module with the label facing downward as shown, into any port **after** the last Memory Module. For example, if you have a Memory Module inserted in port 1, you can insert an Application Module in any of ports 2, 3, or 4. (The port numbers are shown on the back of the calculator.) **Never insert an Application Module into a lower numbered port than a Memory Module.**

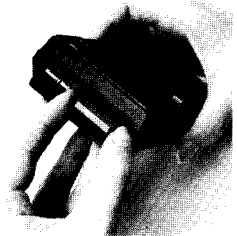

4. If you have additional Application Modules to insert, plug them into any port after the last Memory Module. Be sure to place port covers over unused ports.
5. Turn the calculator on and follow the instructions given in this book for the desired application functions.

To remove Application Modules:

1. Turn the HP-41C off! Failure to do so could damage both the calculator and the Module.
2. Grasp the desired Module handle and pull it out as shown.



3. Place a port cap into the empty ports.

Mixing Memory Modules and Application Modules

Any optional accessories (such as the HP-82104A Card Reader, or the HP-82143A Printer) should be treated in the same manner as Application Modules. That is, they can be plugged into any port after the last Memory Module. Also, the HP-41C should be turned off prior to insertion or removal of these extensions.

The HP-41C allows you to leave gaps in the port sequence when mixing Memory and Application Modules. For example, you can plug a Memory Module into port 1 and an Application Module into port 4, leaving ports 2 and 3 empty.

FORMAT OF USER INSTRUCTIONS

The completed User Instruction Form—which accompanies each program—is your guide to operating the programs in this Pac.

The form is composed of five labeled columns. Reading from left to right, the first column, labeled STEP, gives the instruction step number.

The INSTRUCTIONS column gives instructions and comments concerning the operations to be performed.

The INPUT column specifies the input data, the units of data if applicable, or the appropriate alpha response to a prompted question. Data input keys consist of 0 to 9 and the decimal point (the numeric keys), **EEX** (enter exponent), and **CHS** (change sign).

The FUNCTION column specifies the keys to be pressed after keying in the corresponding input data.

The DISPLAY column specifies prompts, intermediate and final answers, and their units, where applicable.

Above the DISPLAY column is a box which specifies the minimum number of data storage registers necessary to execute the program. Refer to the Owner's Handbook for information on how the SIZE function affects storage configuration.

A WORD ABOUT PROGRAM USAGE

Catalog



When an Application Module is plugged into a port of the HP-41C, the contents of the Module can be reviewed by pressing  **CATALOG** 2 (the Extension Catalog). Executing the **CATALOG** function lists the name of each program or function in the Module, as well as functions of any other extensions which might be plugged in.

Overlays

Overlays have been included for some of the programs in this Pac. To run the program, choose the appropriate overlay, and place it on the calculator. The mnemonics on the overlay are provided to help you run the program. The program's name is given vertically on the left side. When the calculator is in USER mode, a blue mnemonic identifies the key directly above it. Gold mnemonics are similar to blue mnemonics, except that they are above the appropriate key and the shift (gold) key must be pressed before the re-defined key. Once again, USER mode must be set.

ALPHA and USER Mode Notation

This manual uses a special notation to signify ALPHA mode. Whenever a statement on the User Instruction Form is printed in gold, the **ALPHA** key must be pressed before the statement can be keyed in. After the statement is input, press **ALPHA** again to return the calculator to its normal operating mode, or to begin program execution. For example, **XEQ** SECTION means press the following keys: **XEQ** **ALPHA** SECTION **ALPHA**.

When the calculator is in USER mode, this manual will use the symbols **A** - **J** and  **A** -  **E** to refer to the reassigned keys in the top two rows. These key designations will appear on the User Instruction Form and in the keystroke solutions to sample problems.

Optional Printer

When the optional printer is plugged into the HP-41C along with this Application Module, all results will be printed automatically. You may also want to keep a permanent record of the values input to a certain program. A convenient way to do this is to set the Print Mode switch to NORMAL before running the program. In this mode, all input values and the corresponding keystrokes will be listed on the printer, thus providing a record of the entire operation of the program.

Downloading Module Programs

If you wish to trace execution, to modify, to record on magnetic cards, or to print a program in this Application Module, it must first be copied into the HP-41C's program memory. For information concerning the HP-41C's COPY function, see the Owner's Handbook. It is not necessary to copy a program in order to run it.

Program Interruption

These programs have been designed to operate properly when run from beginning to end, without turning the calculator off (remember, the calculator may turn itself off). If the HP-41C is turned off, it may be necessary to set flag 21 (SF 21) to continue proper execution.

Use of Labels

You should generally avoid writing programs into the calculator memory that use program labels identical to those in your Application Module. In case of a label conflict, the label within program memory has priority over the label within the Application Pac program.

Label Conflicts With Other Application Pacs

Several labels used in the Stress Analysis module have the same name as those used in other modules. If you have this module and another module plugged into your HP-41C at the same time, you should make sure that the module whose programs you want to use is in the lowest-numbered port to avoid conflicting use of these labels.

Label	Pac
ATANY/X PROPPED *L1	Structural Analysis
BEAM SECTION *M	
CANT SIMPLE *M1	
FIXED SPAN *P	
FIXL VECTOR *P1	
FIXR *AI *W	
MOMENTS *B *W1	
NSPAN *L	
SIZE?	Structural Analysis, Games, Real Estate

Assigning Program Names

Key assignments to keys **[A]** - **[J]** and **[A]** - **[E]** take priority over the automatic assignments of local labels in the Application Module. Be sure to clear previously assigned functions before executing a Module program.

SECTION PROPERTIES

The properties of polygonal sections (see figure 1) may be calculated using this program. The (x, y) coordinates of the vertices of the polygon (which must be located entirely within the first quadrant) are input sequentially for a complete, clockwise path around the polygon. Holes in the cross section, which do not intersect the boundary, may be deleted by following a counter-clockwise path.

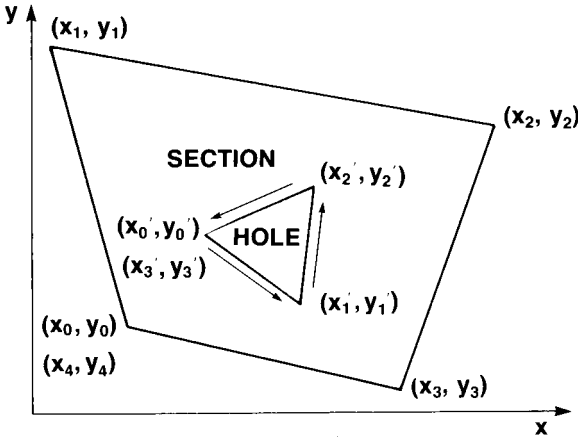

Figure 1

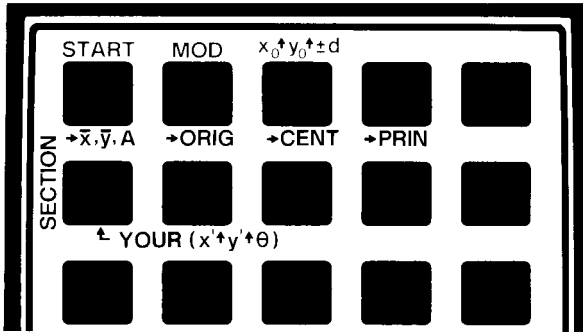

Figure 2

The keyboard overlay (see figure 2) defines the keys according to their function in SECTION. The shifted **A** key can be used to clear an existing section and restart a new input sequence. The shifted **B** key restarts the input sequence but does not clear the existing section. Its use allows deletion, addition, and correction of existing sections.

A special feature on the shifted **C** key allows addition or deletion of circular areas. After the point by point traverse of the section has been completed, circular deletions or additions are specified by the (x, y) coordinates of the circle centers and by the circle diameters. If the diameter is specified as a

positive number, the circular areas are added. A negative diameter causes circular areas to be deleted. Example 4 shows an application of this feature.

After all values have been input, the coordinates of the centroid (\bar{x}, \bar{y}) and the area A of the section may be output using key **[A]**. The moment of inertia about the original x axis I_x , about the original y axis I_y and the product of inertia I_{xy} are output using **[B]**. Similar moments, $I_{\bar{x}}$, $I_{\bar{y}}$, and $I_{\bar{x}\bar{y}}$, about an axis translated to the centroid of the section are calculated when **[C]** is pressed.

Pressing **[D]** calculates the moments of inertia, $I_{\bar{x}\Delta}$ and $I_{\bar{y}\Delta}$, about the principal axis. The rotation angle Δ between the principal axis and the axis which was translated to the centroid is also calculated. The moments of inertia I_x' , I_y' , the polar moment of inertia J and the product of inertia I_{xy}' may be calculated about any arbitrary axis by specifying its location and rotation with respect to the original axis and pressing **[F]**.

Equations:

$$A = - \sum_{i=0}^n (y_{i+1} - y_i)(x_{i+1} + x_i)/2$$

$$\bar{x} = \frac{-1}{A} \sum_{i=0}^n [(y_{i+1} - y_i)/8] [(x_{i+1} + x_i)^2 + (x_{i+1} - x_i)^2/3]$$

$$\bar{y} = \frac{1}{A} \sum_{i=0}^n [(x_{i+1} - x_i)/8] [(y_{i+1} + y_i)^2 + (y_{i+1} - y_i)^2/3]$$

$$I_x = \sum_{i=0}^n [(x_{i+1} - x_i)(y_{i+1} + y_i)/24] [(y_{i+1} + y_i)^2 + (y_{i+1} - y_i)^2]$$

$$I_y = - \sum_{i=0}^n [(y_{i+1} - y_i)(x_{i+1} + x_i)/24] [(x_{i+1} + x_i)^2 + (x_{i+1} - x_i)^2]$$

$$I_{xy} = \sum_{i=0}^n \frac{1}{(x_{i+1} - x_i)} \left[\frac{1}{8} (y_{i+1} - y_i)^2 (x_{i+1} + x_i)(x_{i+1}^2 + x_i^2) \right.$$

$$+ \frac{1}{3} (y_{i+1} - y_i)(x_{i+1}y_i - x_iy_{i+1})(x_{i+1}^2 + x_{i+1}x_i + x_i^2)$$

$$\left. + \frac{1}{4} (x_{i+1}y_i - x_iy_{i+1})^2(x_{i+1} + x_i) \right]$$

$$I_{\bar{x}} = I_x - A\bar{y}^2$$

$$I_{\bar{y}} = I_y - A\bar{x}^2$$

$$I_{\bar{x}\bar{y}} = I_{xy} - A\bar{x}\bar{y}$$

$$\Delta = \frac{1}{2} \tan^{-1} \left(\frac{-2I_{\bar{x}\bar{y}}}{I_{\bar{x}} - I_{\bar{y}}} \right)$$

$$I_x' = I_{\bar{x}} \cos^2 \theta + I_{\bar{y}} \sin^2 \theta - I_{\bar{x}\bar{y}} \sin 2\theta$$

$$I_y' = I_{\bar{y}} \cos^2 \theta + I_{\bar{x}} \sin^2 \theta + I_{\bar{x}\bar{y}} \sin 2\theta$$

$$J = I_x' + I_y'$$

$$I_{xy}' = \frac{(I_{\bar{x}} - I_{\bar{y}})}{2} \sin 2\theta + I_{\bar{x}\bar{y}} \cos 2\theta$$

$$A_{\text{circle}} = \frac{\pi d^2}{4}$$

$$I_{\text{circle}} = \frac{\pi d^4}{64}$$

where:

x_{i+1} is the x coordinate of the current vertex point;

y_{i+1} is the y coordinate of the current vertex point;

x_i is the x coordinate of the previous vertex point;

y_i is the y coordinate of the previous vertex point;

A is the area;

\bar{x} is the x coordinate of the centroid;

\bar{y} is the y coordinate of the centroid;

I_x is the moment of inertia about the x-axis;

I_y is the moment of inertia about the y-axis;

I_{xy} is the product of inertia;

$I_{\bar{x}}$ is the moment of inertia about the x-axis translated to the centroid;

$I_{\bar{y}}$ is the moment of inertia about the y-axis translated to the centroid;

$I_{\bar{x}\bar{y}}$ is the product of inertia about the translated axis;

Δ is the angle between the translated axis and the principal axis;

- $I_{\bar{x}\Delta}$ is the moment of inertia about the translated, rotated, principal x-axis;
- $I_{\bar{y}\Delta}$ is the moment of inertia of inertia about the translated, rotated, principal y-axis;
- θ is the angle between the original axis and an arbitrary axis;
- I_x' is the x moment of inertia about the arbitrary axis;
- I_y' is the y moment of inertia about the arbitrary axis;
- J is the polar moment of inertia about the arbitrary axis;
- I_{xy}' is the product of inertia about the arbitrary axis;
- d is the diameter of a circular area.

Reference:

Wojciechowski, Felix; *Properties of Plane Cross Sections; Machine Design*; p. 105, Jan. 22, 1976.

Remarks:

The polygon must be entirely contained in the first quadrant.

Rounding errors will accumulate if the centroid of the section is a large distance from the origin of the coordinate system.

Curved boundaries may be approximated by straight line segments.

				SIZE: 017
STEP	INSTRUCTIONS	INPUT	FUNCTION	DISPLAY
1	Initialize program.		XEQ SECTION	X0=?
2	Key in x value at initial vertex.	x	R/S	Y0=?
3	Key in y value at initial vertex.	y	R/S	X1=?
4	Key in (x, y) coordinates of next clockwise vertex.	x	R/S	YN=?
		y	R/S	XN=?
5	Repeat Step 4 for each point of the polygon including the initial point.			
6	To delete subsections within the section, press ■ ⏏ and go to Step 2, but traverse in a counter-clockwise direction.		■ B	X0=?
7	To add subsections to the section, press ■ ⏏ and go to Step 2.		■ B	X0=?
8	Add any circular areas	x	ENTER ▶	
		y	ENTER ▶	
		d	■ C	0.000 00
	or delete any circular areas.	x	ENTER ▶	
		y	ENTER ▶	
		d	CHS ■ C	0.000 00

STEP	INSTRUCTIONS	INPUT	FUNCTION	DISPLAY
9	<p>Calculate any or all of the following*:</p> <ul style="list-style-type: none"> Centroid and area; Properties about original axis; Properties about an axis translated to centroid Properties about principal axis and angular orientation of principal axis; <p>OR</p> <p>Specify an arbitrary axis and rotation angle and calculate properties about that axis.</p>		<p>A*</p> <p>B*</p> <p>C*</p> <p>D*</p>	<p>CENTROID</p> <p>ORIGINAL AXIS</p> <p>CENTROID AXIS</p> <p>PRINCIPAL AXIS</p>
		x' y' θ	<p>ENTER*</p> <p>ENTER*</p> <p>F*</p>	YOUR AXIS
10	<p>For a new problem, press ■ A and go to Step 2. To modify the current section, go to Step 6 or Step 7.</p> <p>* If your HP-41C does not have a printer, you must press R/S for output of each section property.</p>		<p>■ A</p>	<p>X0=?</p>

Example 1:

What is the moment of inertia about the x-axis (I_x) for the rectangular section shown? What is the amount of inertia about the neutral axis through the centroid of the section ($I_{x\Delta}$)?

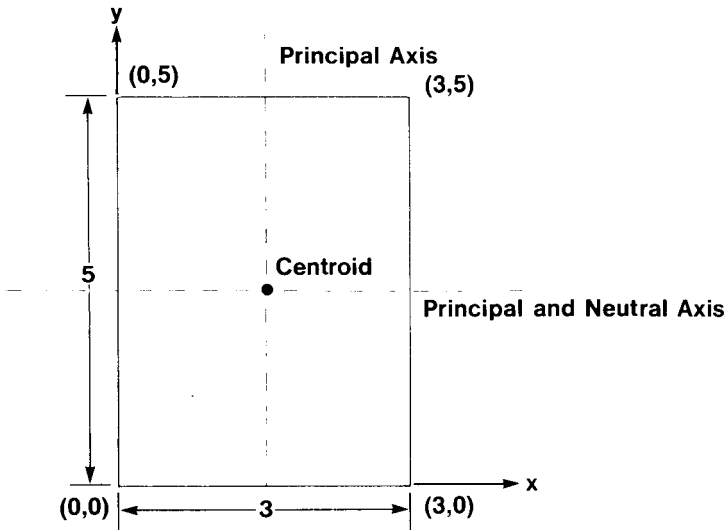

Keystrokes: (SIZE \geq 017)

[XEQ] [ALPHA] SECTION [ALPHA]

0 [R/S]

0 [R/S]

0 [R/S]

5 [R/S]

3 [R/S]

5 [R/S]

3 [R/S]

0 [R/S]

0 [R/S]

0 [R/S]

[B]

[R/S] *

[R/S] *

[R/S] *

[D]

[R/S] *

[R/S] *

[R/S] *

[R/S] *

Display:**X0=?****Y0=?****X1=?****Y1=?****X2=?****Y2=?****X3=?****Y3=?****X4=?****Y4=?****X5=?****ORIGINAL AXIS****IX=125.0E0****IY=45.00E0****IXY=56.25E0****PRINCIPAL AXIS****IX=31.25****IY=11.25E0****IXY=0.000E0** **Δ =0.000E0**

Since $\Delta = 0$ we would expect $I_{\bar{x}\Delta}$ to equal $I_{\bar{x}}$. Press [C] to calculate $I_{\bar{x}}$, $I_{\bar{y}}$, and $I_{\bar{x}\bar{y}}$ and you will see that this prediction is correct. Also, $I_{\bar{x}\bar{y}}$ is zero about the principal axis.

Keystrokes:

[C]

[R/S] *

[R/S] *

[R/S] *

Display:**CENTROID AXIS****IX=31.25E0****IY=11.25E0****IXY=0.000E0**

* Press [R/S] if you are not using a printer.

Example 2:

Calculate the section properties for the beam shown below.

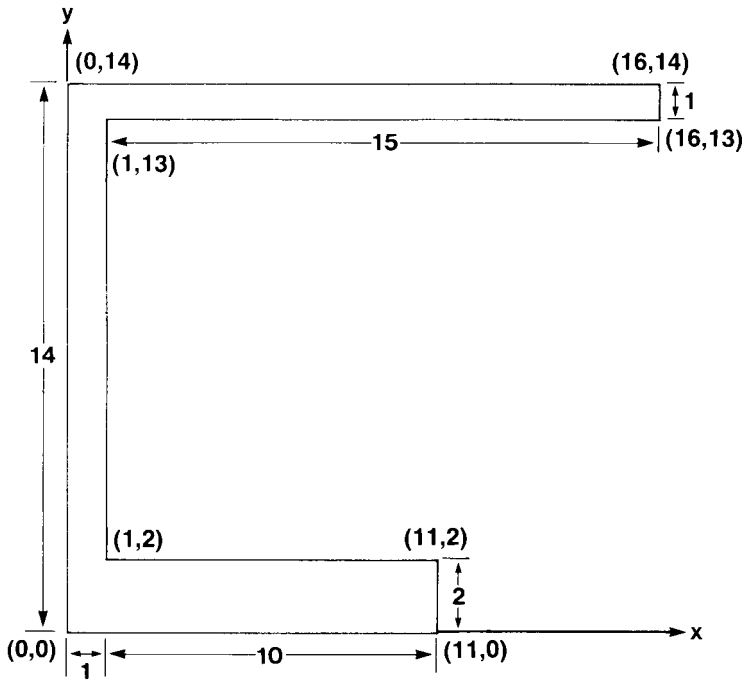

Keystrokes: (SIZE ≥ 017)

Display:

```

XEQ ALPHA SECTION ALPHA
0 R/S 0 R/S 0 R/S 14 R/S
16 R/S 14 R/S 16 R/S 13 R/S
1 R/S 13 R/S 1 R/S 2 R/S
11 R/S 2 R/S 11 R/S 0 R/S
0 R/S 0 R/S
    
```

X0=?

X9=?

```

A
R/S *
R/S *
R/S *
    
```

CENTROID
X=5.194E0
Y=6.541E0
AREA=49.00E0

```

B
R/S *
R/S *
R/S *
    
```

ORIGINAL AXIS
IX=3.676E3
IY=2.256E3
IXY=1.890E3

* Press R/S if you are not using a printer.

Keystrokes:**C****R/S** ***R/S** ***R/S** ***D****R/S** ***R/S** ***R/S** ***R/S** ***Display:**

CENTROID AXIS

IX=1.580E3

IY=934.5E0

IXY=225.6E0

PRINCIPAL AXIS

IX=1.651E3

IY=863.5E0

IXY=0.000E0

 $\Delta = -17.48E0$

Below is a figure showing the translated axis and the rotated, principal axis of example 2. Notice that the sign of the angle is negative, representing a clockwise rotation.

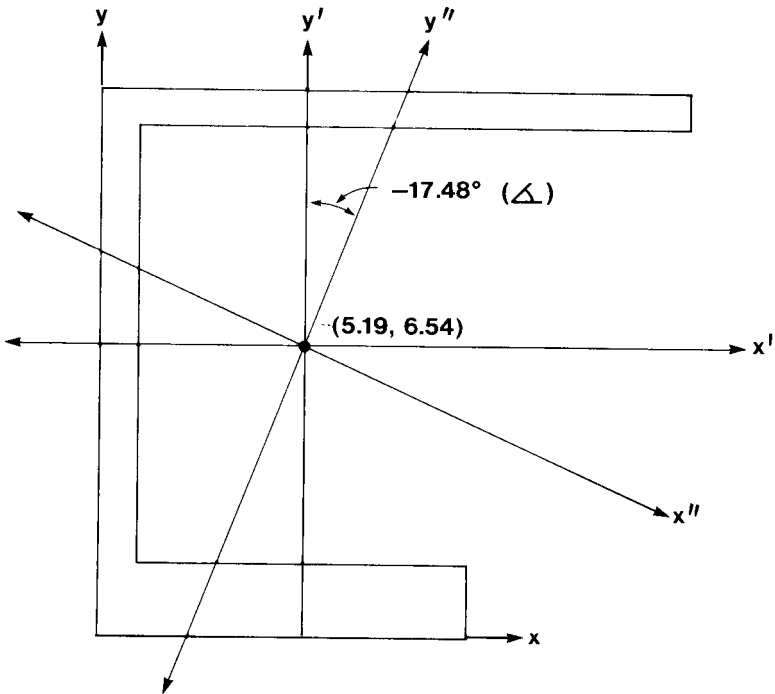

* Press **R/S** if you are not using a printer.

Example 3:

What is the centroid of the section below? The inner triangular boundary denotes an area to be deleted.

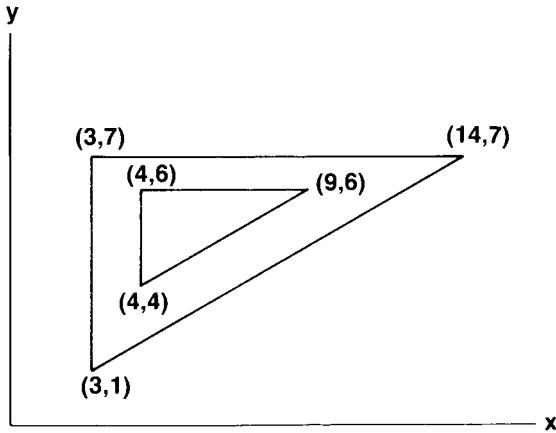

Keystrokes: (SIZE ≥ 017)

Display:

Input for the outer triangle:

XEQ **ALPHA** SECTION **ALPHA** **X0?**=

3 **R/S** 1 **R/S** 3 **R/S** 7 **R/S** **X4?**=

14 **R/S** 7 **R/S** 3 **R/S** 1 **R/S** **X4?**=

Delete inner triangle:

█ **B** **X0?**=

4 **R/S** 4 **R/S** 9 **R/S** 6 **R/S** **X4?**=

4 **R/S** 6 **R/S** 4 **R/S** 4 **R/S** **CENTROID**

A **X=6.845E0**

R/S * **Y=4.940E0**

R/S * **AREA=28.00E0**

* Press **R/S** if you are not using a printer.

Example 4:

For the part below, compute the polar moment of inertia about point A. Point A denotes the center of a hole about which the part rotates. The area of the hole must be deleted from the cross section.

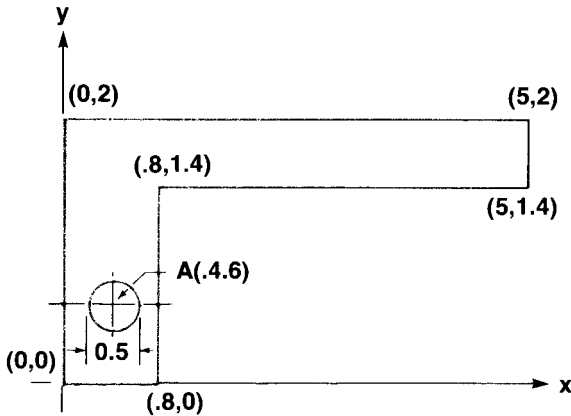

Keystrokes: (SIZE ≥ 017)

Display:

XEQ **ALPHA** SECTION **ALPHA**
 0 **R/S** 0 **R/S** 0 **R/S** 2 **R/S**
 5 **R/S** 2 **R/S** 5 **R/S** 1.4 **R/S**
 .8 **R/S** 1.4 **R/S** .8 **R/S** 0 **R/S**
 0 **R/S** 0 **R/S**

X0=?

X7=?

Delete hole:

.4 **ENTER+** .6 **ENTER+** .5 **CHS**

C

0.000 00

Compute J about (0.4, 0.6) with θ of zero.

.4 **ENTER+** .6 **ENTER+** 0 **F**

YOUR AXIS

R/S *

IX=3.911E0

R/S *

IY=19.54E0

R/S *

IXY=6.930E0

R/S *

J=23.45E0

* Press **R/S** if you are not using a printer.

BEAMS

This program calculates deflection, slope, moment and shear at any point for:

simple beams;



cantilever beams;

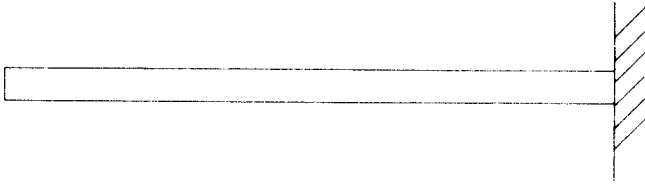

fixed beams;



and propped cantilever beams.

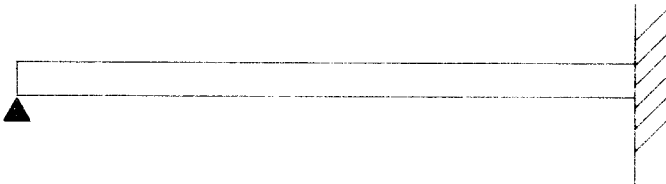

Beam loading may include combinations of point loads, distributed loads, applied moments and trapezoidally distributed loads. Any number or combination of loads may be used assuming sufficient data storage registers are available. Minimum size must be set according to the formula below:

$$\begin{aligned} \text{SIZE}_{\min} = & 20 + 2 * \text{Number of distributed loads} \\ & + 3 * \text{Number of point loads} \\ & + 3 * \text{Number of applied moments} \\ & + 5 * \text{Number of trapezoidal loads} \end{aligned}$$

A size setting of 40 is adequate for most loadings.

If the size is set larger than 23 but smaller than necessary for program execution the message:

SIZE >= NNN

will be displayed. This message tells you that your last input was ignored and you must increase register size to at least **NNN** to continue program execution.

If you have an optional printer this program will list and plot values of deflection, angle, moment or shear for evenly spaced points along the beam.

The program can be divided into four operating functions: input, editing, calculation, and printing/plotting. The input section is initialized by executing SIMPLE, CANT, FIXED, or PROPPED. This selects the type of beam to be analyzed and prompts for the length of the beam. Key in the length and press **[R/S]**. The display will prompt **RDY A-I**. This indicates that the keys are defined according to the overlay below:

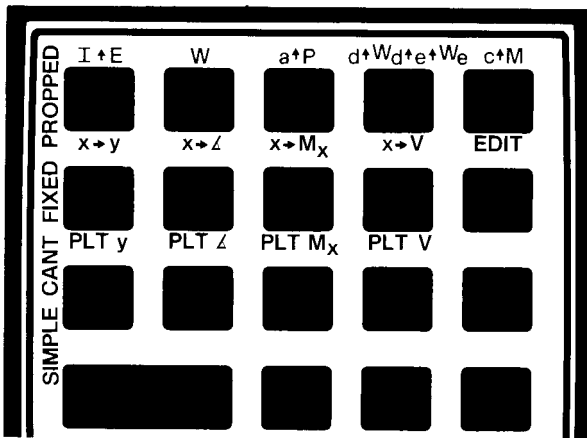

The shifted top row keys allow input of the beam variables. The unshifted top row keys **[A]** – **[D]** allow computation of deflection, slope, moment or shear for a given x . Key **[E]** provides an editing option. The editing option allows you to review all inputs and change input errors. The second row of keys provides printout of beam properties and plotting of beam deflection, slope, moment or shear with the optional printer.

Equations:

For equations, refer to cited reference.

Definitions:

I is the moment of inertia of the section;

E is the modulus of elasticity of the material;

L is the length of the beam;

a is the displacement of the concentrated load from the left end of the beam;

P is the amount of the concentrated load;

c is the displacement of the applied moment from the left end of the beam;

M is the amount of the applied moment;

W is the amount of a uniformly distributed load over the entire beam with dimensions force per unit length;

d is the distance to the beginning of a trapezoidal load;

W_d is the initial value of a trapezoidal load with units of force per unit length;

e is the distance to the end of a trapezoidal load;

W_e is the final value of a trapezoidal load;

x is the point of interest along the beam;

y is the deflection at x ;

Δ is the slope (change in y per change in x) at x ;





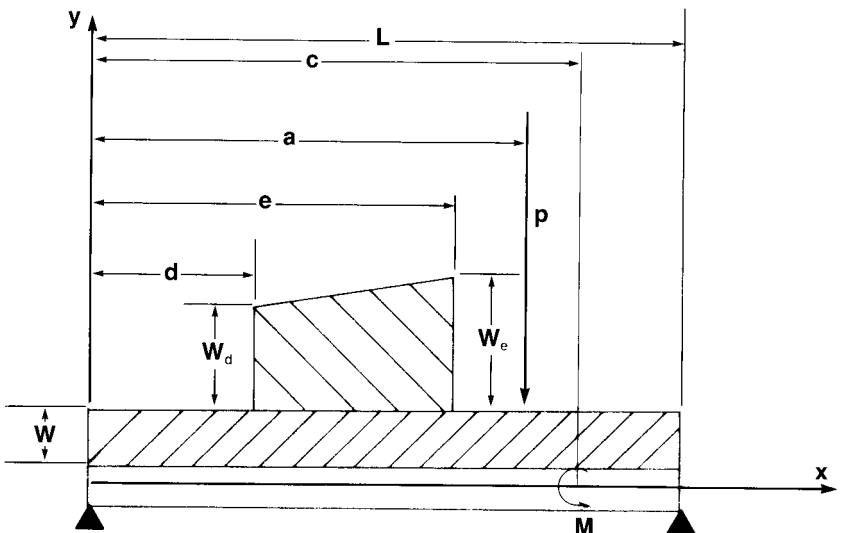

M_x is the internal bending moment at x ;

V is the shear at x .

A simply supported beam with one of each type of load is shown below:



SIGN CONVENTIONS FOR BEAMS

NAME	VARIABLE	SENSE	SIGN
DEFLECTION	y		+
SLOPE	Δ		+
INTERNAL MOMENT	M_x		+
SHEAR	V		+
EXTERNAL FORCE OR LOAD	P or W		+
EXTERNAL MOMENT	M		+

Remarks:

Deflections must not significantly alter the geometry of the problem.

Beams must be of constant cross section for deflection and slope equations to be valid.

Stresses must be in the elastic region.

Programs are not unit dependent. Any mutually consistent set of units will work.

Reference:

Roark, Raymond J., Young, Warren C., *Formulas for Stress and Strain*, McGraw-Hill Book Company, 1975.

				SIZE: 040
STEP	INSTRUCTIONS	INPUT	FUNCTION	DISPLAY
1	Select type of beam. Or Or Or		<input type="checkbox"/> XEQ SIMPLE <input type="checkbox"/> XEQ CANT <input type="checkbox"/> XEQ FIXED <input type="checkbox"/> XEQ PROPPED	L=? L=? L=? L=?
2	Key in length.	L	<input type="checkbox"/> R/S	RDY A-I
3	If you wish to calculate deflection or slope, key in moment of inertia and modulus of elasticity, otherwise go to Step 4.	I E	<input type="checkbox"/> ENTER <input type="checkbox"/> A	I E*I
4	Key in all loadings: Distributed load.	W	<input type="checkbox"/> B	0.000 00
	Point load location and load.	a P	<input type="checkbox"/> ENTER <input type="checkbox"/> C	a 0.000 00

22 Beams

STEP	INSTRUCTIONS	INPUT	FUNCTION	DISPLAY
	Trapezoidal load starting point, starting load, end point, and ending load.	d W_d e W_e	<input type="button" value="ENTER+"/> <input type="button" value="ENTER+"/> <input type="button" value="ENTER+"/> <input type="button" value="D"/>	d W_d e 0.000 00
	Applied moment location and applied moment.	c M	<input type="button" value="ENTER+"/> <input type="button" value="E"/>	c
5	OPTIONAL: Review and/or edit your inputs (e.g. if you wish to modify L, key in a new L and press <input type="button" value="R/S"/>), otherwise just press <input type="button" value="R/S"/> .	(L) (E*I)	<input type="button" value="E"/> <input type="button" value="R/S"/> <input type="button" value="R/S"/> <input type="button" value="R/S"/> : : <input type="button" value="R/S"/>	BEAM TYPE L= E*I= LOAD : : END
	An "END" signifies that all data has been displayed. Pressing <input type="button" value="R/S"/> again will start the edit routine over.			
6	If you have an optional HP-82143A printer and wish to plot, go to Step 9.			
7	Key in x to specify the point of interest and calculate deflection or slope or moment or shear.	x x x x	<input type="button" value="A"/> <input type="button" value="B"/> <input type="button" value="C"/> <input type="button" value="D"/>	y= Δ = MX= V=
8	For a new calculation with the same loading, go to Step 6. For new loads, go to Steps 4 or 5. For new section properties, go to Step 3 but skip Step 4 if no loads change.			
9	Plot deflection or slope or moment or shear.		<input type="button" value="F"/> <input type="button" value="G"/> <input type="button" value="H"/> <input type="button" value="I"/>	BEAM TYPE L= E*I= LOADS X INC=? LIST/PLOT
	Key in x increment.	XINC	<input type="button" value="R/S"/>	
10	Go to Step 8.			

Example 1

What is the total moment at the center of the beam below? (It is not necessary to know the values of E or I to solve this problem.)

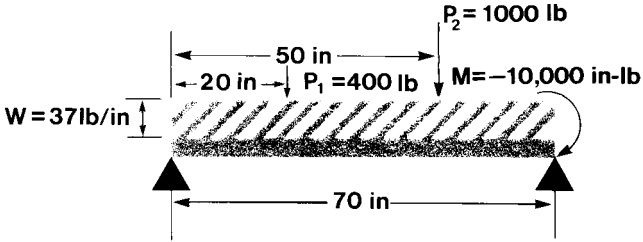

Keystrokes: (SIZE >= 31)

Display:

ENG 3	
XEQ ALPHA SIMPLE ALPHA	L=?
70 R/S	RDY A-I
20 ENTER+ 400 C	0.000 00
50 ENTER+ 1000 C	0.000 00
37 B	0.000 00
70 ENTER+ 10000 CHS E	0.000 00
35 C	MX=31.66E3

Example 2

For the beam below, what are the values of deflection, slope, moment, and shear at an x of 114 inches?

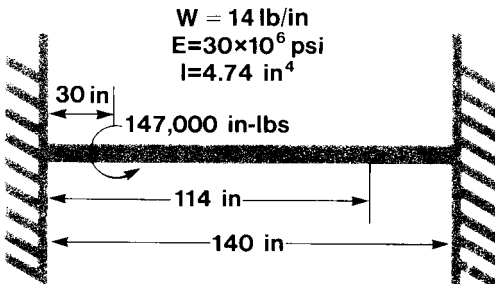

24 Beams

Keystrokes: (SIZE >= 25)

Display:

[ENG] 3
 [XEQ] [ALPHA] FIXED [ALPHA]
 140 [R/S]
 4.74 [ENTER+] 30 [EEX] 6 [A]
 14 [B] 30 [ENTER+]
 147000 [E]

L=?
 RDY A-I

114 [A]
 114 [B]
 114 [C]
 114 [D]

$y=43.72E-3$
 $\Delta=-3.155E-3$
 $MX=13.05E3$
 $V=444.7E0$

Using the edit feature, change the location of the applied moment to 50.

[E]
 [R/S]
 [R/S]
 [R/S]
 [R/S]
 50 [R/S]

FIXED
 $L=140.0E0$
 $E^*I=142.2E6$
 $W=14.00E0$
 $c=30.00E0$
 $M=147.0E3$

Now calculate the bending moment at $x = 70$.

70 [C]

$MX=-41.07E3$

Example 3:

Repeat Example 1, but plot bending moment in increments of 2.5 inches along the length of the beam. An optional HP-82143A thermal printer is required for this problem.

Keystrokes: (SIZE >= 31)

Display:

[ENG] 3
 [XEQ] [ALPHA] SIMPLE [ALPHA]
 70 [R/S]
 20 [ENTER+] 400 [C] 50 [ENTER+]
 1000 [C] 37 [B] 70 [ENTER+]
 10000 [CHS] [E]

L=?
 RDY A-I
 0.000 00

Keystrokes:**H**2.5 **R/S****Display:**

SIMPLE

 $L=70.00E0$
 $E*I=0.000E0 *$
 $a=20.00E0$
 $P=400.0E0$
 $a=50.00E0$
 $P=1.000E3$
 $W=37.00E0$
 $c=70.00E0$
 $M=-10.00E3$
 END
XINC?
 $X=0.000E0$
 $MX=0.000E0$
 $X=2.500E0$
 $MX=4.193E3$
 $X=5.000E0$
 $MX=8.155E3$
 $X=7.500E0$
 $MX=11.09E3$
 $X=10.00E0$
 $MX=15.39E3$

* May take any value in this problem.

Keystrokes:**Display:**

X=12.50E0
MX=18.65E3

X=15.00E0
MX=21.69E3

X=17.50E0
MX=24.50E3

X=20.00E0
MX=27.07E3

X=22.50E0
MX=28.41E3

X=25.00E0
MX=29.53E3

X=27.50E0
MX=30.41E3

X=30.00E0
MX=31.06E3

X=32.50E0
MX=31.48E3

X=35.00E0
MX=31.66E3

X=37.50E0
MX=31.62E3

X=40.00E0
MX=31.34E3

Keystrokes:**Display:**

X=42.50E0
MX=30.84E3

X=45.00E0
MX=30.10E3

X=47.50E0
MX=29.13E3

X=50.00E0
MX=27.93E3

X=52.50E0
MX=24.00E3

X=55.00E0
MX=19.83E3

X=57.50E0
MX=15.44E3

X=60.00E0
MX=10.81E3

X=62.50E0
MX=5.958E3

X=65.00E0
MX=869.6E0

X=67.50E0
MX=-4.450E3

X=70.00E0
MX=0.000E0

28 Beams

Keystrokes:

Display:

```
      PLOT OF BEAM
      X <UNITS= 1.> ↓
      Y <UNITS= E 4.> →
      -0.44          3.17
      0.00
      |-----|
      0.0  x
      2.5  | x
      5.0  |  x
      7.5  |   x
      10.0 |    x
      12.5 |     x
      15.0 |      x
      17.5 |       x
      20.0 |        x
      22.5 |         x
      25.0 |          x
      27.5 |           x
      30.0 |            x
      32.5 |             x
      35.0 |              x
      37.5 |               x
      40.0 |                x
      42.5 |                 x
      45.0 |                  x
      47.5 |                   x
      50.0 |                    x
      52.5 |                     x
      55.0 |                      x
      57.5 |                       x
      60.0 |                        x
      62.5 |                         x
      65.0 |                          x
      67.5 |                           x
      70.0 |                            x
```

Note that the value of moment at $X = 70.00$ does not equal the applied moment of $-10,000$. This is due to the fact that internal moment is undefined at the point of application of an applied moment. Similarly, shear is undefined directly under a point load.

Example 4:

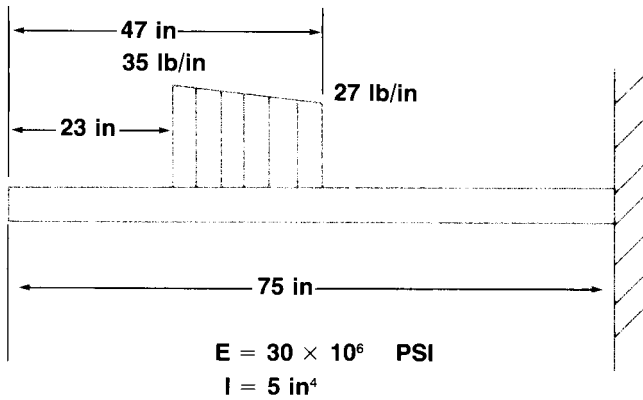

Calculate deflection, slope, moment and shear for the beam above at the point $x = 40$.

Keystrokes: (SIZE ≥ 25)

[ENG] 3
 [XEQ] [ALPHA] CANT [ALPHA]
 75 [R/S]
 23 [ENTER+] 35 [ENTER+] 47 [ENTER+] 27 [D]
 5 [ENTER+] 30 [EEX] 6 [A]
 40 [A]
 40 [B]
 40 [C]
 40 [D]

Display:

L=?
 RDY A-I
 0.000 00
 150.0 06
 $y = -87.66E-3$
 $\Delta = 4.006E-3$
 $MX = -4.785E3$
 $V = -546.8E0$

SIMPLY SUPPORTED CONTINUOUS BEAMS

This program, in combination with the beam program `SIMPLE`, solves for the intermediate couples present at the supports of a continuous beam.

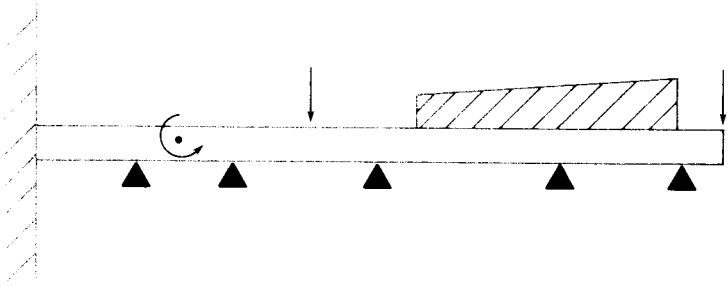

Each span of the beam may have a unique length, cross section, modulus of elasticity and/or loading. Beam ends may be rigidly fixed or simply supported.

The program `SIMPLE` is used to input the length, section moment of inertia, and loading for each span of the continuous beam. After the data for a particular span has been keyed in using `SIMPLE`, program `SPAN` is executed to transform the data. `MOMENTS`, which is called after all spans have been entered, computes the internal bending moments at each intermediate support.

If the left end of the continuous beam is rigidly fixed, execute `FIXL` instead of `SIMPLE`. After some computation time the prompt `L=?` will be displayed indicating that the calculator is ready for the first span.

If the right end of the continuous beam is rigidly fixed, key in the span properties as usual. After all spans (including the last span) have been completed, execute `FIXR`.

If you find that you have made an error during input of a span or wish to modify a span after initial computation, the `NSPAN` program may be used. Simply key in your data, key in the span number (1 = leftmost span) and execute `NSPAN`.

The number of spans is limited only by the number of data storage registers.

A rule of thumb for the required size is:

$$\begin{aligned} \text{SIZE} &= 35 + 4 * (\text{Number of spans}) \\ &\quad + 4 * (\text{Number of fixed ends}) \end{aligned}$$

A moderately complex problem with 3 spans takes less than 50 registers. With three optional plug in RAM modules, over 50 spans could be combined.

If you set the size larger than 23* but smaller than necessary for problem solution, the prompt

SIZE >= NNN

will be displayed during data input. This indicates that the size should be increased to at least **NNN**.

Algorithm:

The program starts by assuming that all internal moments are zero. Based on this assumption it calculates the moment across the first intermediate supports using:

$$M_1 = \frac{(\Delta_1 - \Delta_2) - \frac{M_0 L_1}{6E_1 I_1} - \frac{M_2 L_2}{6E_2 I_2}}{\left(\frac{L_1}{3E_1 I_1} + \frac{L_2}{3E_2 I_2} \right)}$$

The following definitions apply:

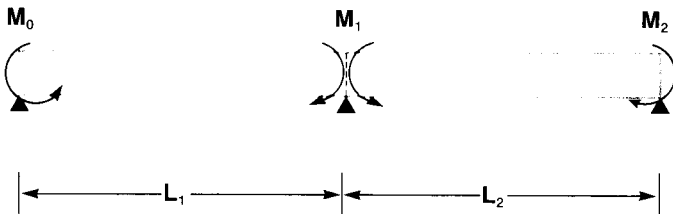

Δ_1 is the slope of the right end of beam one assuming $M_1 = 0$.

Δ_2 is the slope at the left end of beam two assuming $M_1 = 0$.

After calculation M_1 is used in an analogous equation for the next support. This is repeated until the end of the beam is reached. The program repeats this procedure until all calculated moments remain unchanged within the ENG 3 display setting for one complete cycle of moment calculations.

Reference:

Roark, Raymond J., Young, Warren C.; *Formulas for Stress and Strain*, McGraw-Hill, 1975.

* Size of 30 is required to start with the left end fixed.

Remarks:

If a span has no loads, use a point load of zero located anywhere in the span.

If a fixed end is specified, the wall reactions are computed and output as if the fixed end constituted another intermediate support.

				SIZE: >30	
STEP	INSTRUCTIONS	INPUT	FUNCTION	DISPLAY	
1	Select a simply supported beam or a beam with a fixed left end.		[XEQ] SIMPLE [XEQ] FIX	L=? L=?	
2	Key in length of span.	L	[R/S]	RDY A-I	
3	If you know the moment of inertia, key it in (otherwise use 1.00).	I(1)	[ENTER+]	I	
4	If you know the modulus or elasticity key it in (otherwise use 1.00).	E(1)	[A]	E*I	
5	Key in all loadings: Distributed load.	W	[B]	0.000 00	
	Point load location and load.	a P	[ENTER+] [C]	a 0.000 00	
	Trapezoidal load starting point, starting load, end point, and ending load.	d W _d e W _e	[ENTER+] [ENTER+] [ENTER+] [D]	d W _d e 0.000 00	
	Applied moment location and applied moment.	c M	[ENTER+] [E]	c 0.000 00	
	6	OPTIONAL: Review and/or edit your inputs (e.g. if you wish to modify L, key in a new L and press [R/S]. Otherwise just press [R/S].)	(L) (E*I)	[E] [R/S] [R/S] [R/S]	SIMPLE L= E*I= LOAD
		An "END" signifies that all data has been displayed. Pressing [R/S] again will start the edit routine over.		[R/S]	END
7	OPTIONAL: Document your inputs on your optional HP-82143A printer.		[F]		
8	Add this span to the beam OR Replace a previous span with new data.	SPAN#	[XEQ] SPAN [XEQ] NSPAN	L=? L=?	
	9	Go to Step 2 for next span. Skip steps 3 and 4 if the section properties do not change.			

STEP	INSTRUCTIONS	INPUT	FUNCTION	DISPLAY
10	If the right end is fixed rather than simply supported.		XEQ FIXR	L=?
11	Calculate internal moments (L and R refer to the left and right sides of each support).		XEQ MOMENTS R/S * R/S * R/S * R/S * : : R/S	INT MOMENTS M1L= M1R= M2L= M2R= : : L=?
12	For a new case, go to step 2. * Use R/S if you do not have a printer.			

Example 1:

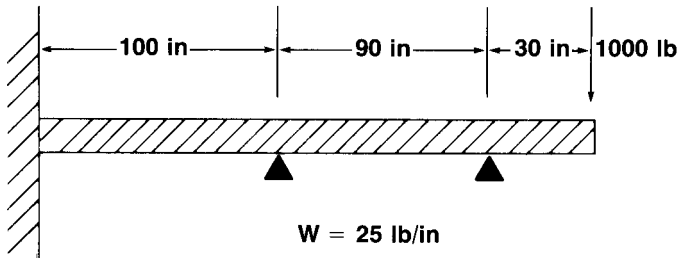

Compute the couples at the wall and the intermediate support for the beam above. Prove that these moments are correct by matching the slope at the left side of the support with the slope at the right side of the support. If we assume that the section properties are constant along the beam, they cancel out of the equation and we may use:

$$E = I = 1$$

Keystrokes: (SIZE \geq 34)

Display:

ENG 3

Fixed left end:

XEQ **ALPHA** FIXL **ALPHA**

L=?

Span 1:

100 **R/S**

RDY A-I

1 **ENTER** 1 **A**

1.000 00

25 **B**

0.000 00

XEQ **ALPHA** SPAN **ALPHA**

L=?

34 Simply Supported Continuous Beams

Span 2:

90 **R/S** 25 **B** 0.000 00

Include cantilevered end as an applied moment at $c = 90$ in span 2.

$$M = -(30 * 1000) - (30 * (30/2) * 25)$$

90 ENTER+ 1000 CHS ENTER+	
30 X	
LASTX ENTER+ X 2 +	
25 X -	-41.25 03
B E	0.000 00
XEQ ALPHA SPAN ALPHA	L=?
XEQ ALPHA MOMENTS ALPHA	INT MOMENTS
R/S *	M1L=-25.24E3
R/S *	M1R=25.24E3
R/S *	M2L=-12.03E3
R/S *	M2R=12.03E3

Check results:

First compute slope at right end of first section.

XEQ ALPHA SIMPLE ALPHA	L=?
100 R/S 0 ENTER+	
25.24 EEX 3 B E	0.000 00
25 B 100 ENTER+	
12.03 CHS EEX 3 B E	0.000 00
100 B	$\Delta = 220.0E3$

Compute slope at left end of second section.

XEQ ALPHA SIMPLE ALPHA	L=?
90 R/S 0 ENTER+	
12.03 EEX 3 B E	0.000 00
25 B 90 ENTER+	
1000 CHS ENTER+ 30 X LASTX	
ENTER+ X	
2 + 25 X - B E	0.000 00
0 B	$\Delta = 220.3E3$

Since the slopes agree, the moments have been correctly balanced.**

* Press **R/S** if you are not using a printer.

** The term slope is used loosely here since we do not know E or I and thus have assumed the rather arbitrary value of 1.00. The slight difference in the computed slopes arises because the moments were keyed in as four digit approximations of 10 digit numbers.

Example 2:

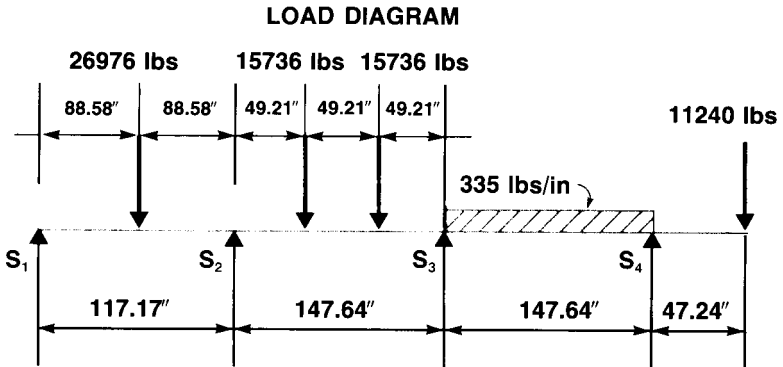

Find the moments at points S_2 and S_3 for the configuration above. Assume the product of EI is the same for all sections and thus cancels out of the solutions (use 1 for E and I).

Keystrokes: (SIZE \geq 39)

```

XEQ ALPHA SIMPLE ALPHA
177.17 R/S
1 ENTER+ 1 A
88.58 ENTER+ 26976 C
XEQ ALPHA SPAN ALPHA
147.64 R/S
49.21 ENTER+ 15736 C
49.21 ENTER+ + 15736 C
XEQ ALPHA SPAN ALPHA
147.64 R/S 335 B
147.64 ENTER+ 47.24 ENTER+
11240 CHS x E
XEQ ALPHA SPAN ALPHA
XEQ ALPHA MOMENTS ALPHA
R/S *
R/S *
R/S *
R/S *

```

Display:

```

L=?
RDY A-I
1.000 00
0.000 00
L=?
0.000 00
0.000 00
L=?
0.000 00
0.000 00
L=?
INT MOMENTS
M1L=-720.2E3
M1R=720.2E3
M2L=-530.8E3
M2R=530.8E3

```

* Press **R/S** if you are not using a printer.

36 Simply Supported Continuous Beams

If the concentrated load on span one (26976) were replaced with a load of 30000, what would the moments be?

```

R/S *                               L=?
177.17 R/S
88.58 ENTER+ 30000 C
1 XEQ ALPHA NSPAN ALPHA          L=?
XEQ ALPHA MOMENTS ALPHA         INT MOMENTS
R/S                               M1L=-778.3E3
R/S                               M1R=778.3E3
R/S                               M2L=-516.3E3
R/S                               M2R=516.3E3

```

If you do have the optional HP-82143A thermal printer, plot the moment distribution for span 1. Use an increment of 10.

```

XEQ ALPHA SIMPLE ALPHA          L=?
177.17 R/S 88.58 ENTER+
30000 C                          0.000 00
177.17 ENTER+
778.3 CHS EEX 3 E                0.000 00
H                                SIMPLE

                                L=177.2E0
                                E*I=0.000E0*

                                a=88.58E0
                                P=30.00E3

                                c=177.2E0
                                M=-778.3E3
                                END
                                XINC?
                                X=0.000E0
                                MX=0.000E0

                                X=10.00E0
                                MX=106.1E3

```

10 R/S

*May take any value in this problem.

Keystrokes:**Display:** $X=20.00E0$
 $MX=212.2E3$ $X=30.00E0$
 $MX=318.2E3$ $X=40.00E0$
 $MX=424.3E3$ $X=50.00E0$
 $MX=530.4E3$ $X=60.00E0$
 $MX=636.5E3$ $X=70.00E0$
 $MX=742.6E3$ $X=80.00E0$
 $MX=848.6E3$ $X=90.00E0$
 $MX=912.1E3$ $X=100.00E0$
 $MX=718.2E3$ $X=110.00E0$
 $MX=524.3E3$ $X=120.00E0$
 $MX=330.3E3$ $X=130.00E0$
 $MX=136.4E3$ $X=140.00E0$
 $MX=-57.50E3$ $X=150.00E0$
 $MX=-251.4E3$

38 Simply Supported Continuous Beams

Keystrokes:

Display:

X=160.0E0
MX=-445.3E3

X=170.0E0
MX=-639.3E3

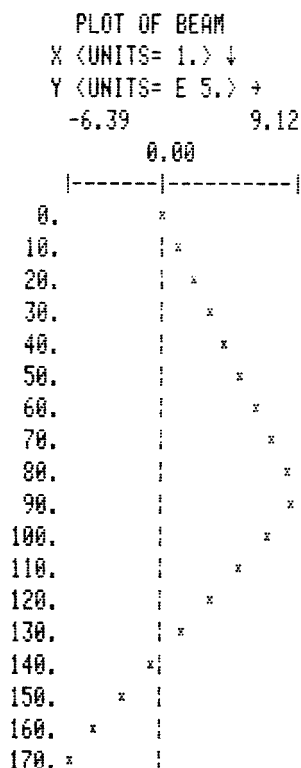

NOTES

COLUMNS

This program computes the axial compressive working load for columns.

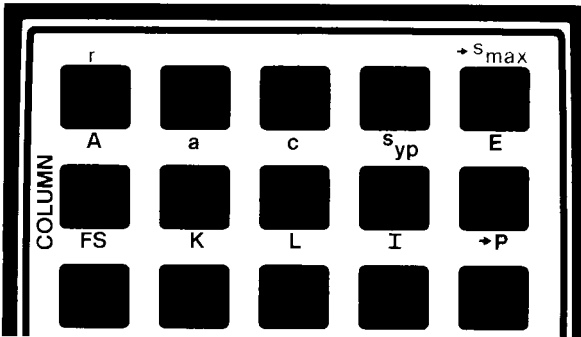

Keys **A** through **I** are used to input the properties of the column. Key **J** initiates calculation of the working load. The shifted **E** key initiates calculation of the maximum stress in the column.

Keying in the radius of a circular column and pressing **A** is equivalent to keying in the area A , moment of inertia I , and distance from the neutral axis to the edge of the column c .

The effective length factor K is used to account for various column end conditions. If both ends are free to rotate but not translate, the value of K is one. Since this is the most common case, K is automatically set to one when the program is initialized. As the ends become more constrained against rotation and motion the value of K goes down approaching a theoretical minimum of 0.5. As the ends become less constrained, K values may rise above two. The table below may be used to estimate K values.

EFFECTIVE LENGTH FACTORS, K

End Conditions	Recommended K values (Theoretical conditions approximated)	Theoretical K values
FIXED-FIXED	0.65	0.5
PINNED-FIXED	0.80	0.7
ROTATION FIXED-FIXED	1.2	1.0
PINNED-PINNED	1.0	1.0
FREE-FIXED	2.1	2.0
ROTATION FIXED-PINNED	2.0	2.0

The initial crookedness a , is initialized equal to zero by the program. The factor of safety FS , is initialized to one by the program.

Equations:

$$P^2 - \left[s_{yp}A + \left(1 + \frac{acA}{I} \right) P_e \right] \frac{P}{FS} + \frac{s_{yp}AP_e}{(FS)^2} = 0$$

$$s_{max} = \frac{P}{A} \left[1 + \frac{acA P_e}{I(P_e - P)} \right]$$

$$P_e = \frac{\pi^2 EI}{(KL)^2}$$

For circular columns:

$$A = \pi r^2$$

$$I = \frac{\pi r^4}{4}$$

$$c = r$$

where:

A is the section area;

a is the initial crookedness of the column;

c is the distance from the minimum neutral axis to the edge of the cross section;

s_{yp} is the yield point stress of the material;

E is the modulus of elasticity of the material;

FS is the factor of safety for the column;

K is the effective length factor for the column;

L is the length of the column;

I is the minimum moment of inertia of the column;

P is the column working load;

s_{max} is the maximum stress in the column;

P_e is the Euler load for the column;

r is the radius of a circular column.

Reference:

Spotts, M. F.; *Design of Machine Elements*, Prentice-Hall, 1971.

Johnson, Bruce G.; Lin, Fung-Jen; *Basic Steel Design*, Prentice-Hall, 1974.

Remarks:

Columns must be nominally straight (a must be small), homogeneous, and of uniform cross section.

The program does not check for local buckling within the section.

				SIZE: 012
STEP	INSTRUCTIONS	INPUT	FUNCTION	DISPLAY
1	Initialize program. (At this point, FS=1, a=0, and K=1).		XEQ RDY A-J	RDY A-J
2	OPTIONAL: If your column is circular key in radius and skip input of A, c and I in Step 3.	r	■ A	A= c= I=
3	Key in, in any order: section area, initial crookedness, distance from neutral axis to edge, yield point stress, modulus of elasticity, factor of safety, effective length factor, length, moment of inertia.	A a c s _{yp} E FS K L I	A B C D E F G H I	A= a= c= SYP= E= FS= K= L= I=
4	Calculate working load and/or maximum stress.		J ■ E	P= SMAX=
5	OPTIONAL: Recall Euler load.		RCL 00	P _e
6	For a new case, go to Step 2 and change any or all inputs.			

Example 1:

A circular steel column 1 meter long, 0.0333 meters in diameter has hinged ends (K = 1). The initial crookedness is assumed to be 0.0016 meters. Find the columns capacity if the factor of safety is 4.

$$E = 2.07 \times 10^{11} \text{ N/m}^2$$

$$s_{yp} = 3.45 \times 10^8 \text{ N/m}^2$$

Keystrokes: (SIZE ≥ 012)

Display:

■ **FIX** 2

XEQ **ALPHA** COLUMN **ALPHA**

RDY A-J

0.0333 **■** **A**

A=3.48E-3

c=0.03

I=9.66E-7

Keystrokes:

.0016 **B**
 1 **H**
 4 **F**
 2.07 **EEX** 11 **E**
 3.45 **EEX** 8 **D**
J

Display:

a=1.60E-3
L=1.00
FS=4.00
E=2.07E11
SYP=345,000,000.0
P=222,539.12

Example 2:

An I-beam is used as a column with fixed ends ($K = 0.65$). Calculate the working load and maximum stress.

FS= 4
 E= 30×10^6 psi
 $s_{yp} = 33,000$ psi
 c= 2.625 in
 a= 0.50 in
 I= 6.16 in⁴
 A= 5.0 in²
 L= 140 in

Keystrokes: (SIZE \geq 012)

FIX 2
XEQ ALPHA COLUMN **ALPHA**
 .65 **G**
 4 **F**
 30 **EEX** 6 **E**
 33000 **D**
 2.625 **C**
 .5 **B**
 6.16 **I**
 5 **A**
 140 **H**
J
E

Display:

RDY= A-J
K=0.65
FS=4.00
E=30,000,000.00
SYP=33,000.00
c=2.63
a=0.50
I=6.16
A=5.00
L=140.00
P=16,389.66
SMAX=7,050.80

MOHR CIRCLE ANALYSIS

This program converts an arbitrary two-dimensional stress configuration to principal stresses, maximum shear stress and rotation angle. It is then possible to calculate the state of stress for an arbitrary orientation angle relative to the original stress state.

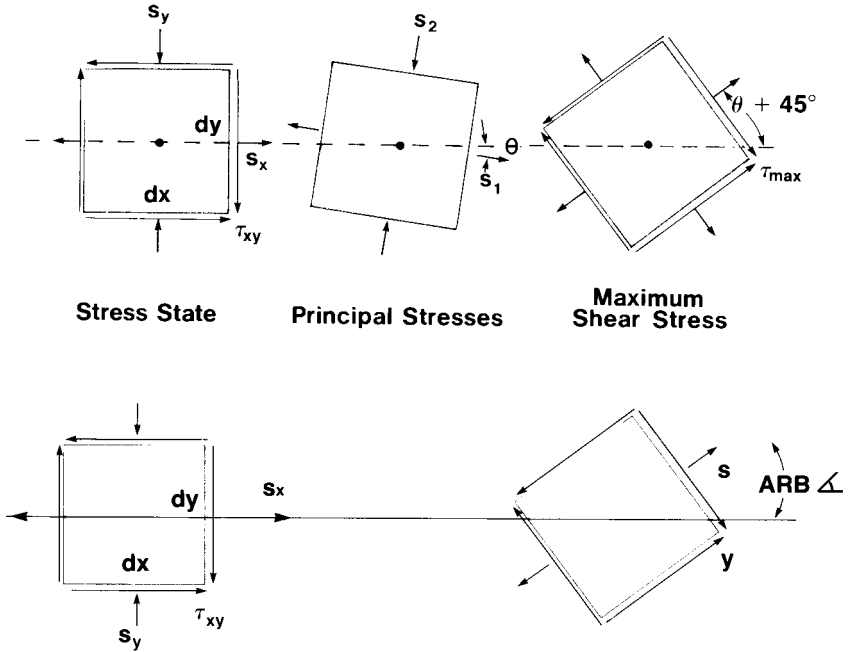

Equations:

$$\tau_{\max} = \sqrt{\left(\frac{s_x - s_y}{2}\right)^2 + \tau_{xy}^2}$$

$$s_1 = \frac{s_x + s_y}{2} + \tau_{\max}$$

$$s_2 = \frac{s_x + s_y}{2} - \tau_{\max}$$

$$\Delta = \frac{1}{2} \tan^{-1} \left(\frac{-2\tau_{xy}}{s_x - s_y} \right)$$

$$s = \frac{s_1 + s_2}{2} + \tau_{\max} \cos 2(\text{ARB } \Delta - \Delta)$$

$$\tau = \tau_{\max} \sin 2(\text{ARB } \Delta - \Delta)$$

where:

s is the normal stress, and τ is the shear stress;

s_x is the stress in the x direction for Mohr circle input;

s_y is the stress in the y direction for Mohr circle input;

τ_{xy} is the shear stress on the element for Mohr circle input;

s_1 and s_2 are the principal normal stresses;

τ_{\max} is the maximum shear stress;

Δ is the orientation angle of the principal axis;

ARB Δ is an arbitrary rotation angle (positive is counterclockwise).

Reference:

Spotts, M. F., *Design of Machine Elements*, Prentice-Hall, 1971.

Remarks:

Negative stresses and strains indicate compression. Positive and negative shear are represented below.

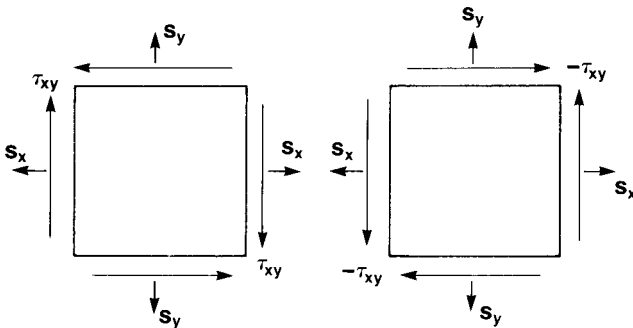

				SIZE: 010
STEP	INSTRUCTIONS	INPUT	FUNCTION	DISPLAY
1	Initialize program.		[XEQ] MOHR	SX=?
2	Key in stress in x direction.	s_x	[R/S]	SY=?
3	Key in stress in y direction.	s_y	[R/S]	SHEAR?
4	Key in x, y shear stress and calculate principal stresses.	τ_{xy}	[R/S] [R/S]* [R/S]* [R/S]*	S1= S2= TAUMAX= Δ =
5	For a new case, go to Step 1. For stress at an arbitrary orientation, key in an arbitrary angle.	ARB Δ	[R/S]* [R/S] [R/S]*	ARB Δ =? TAU= S=
6	For another arbitrary orientation, go to Step 5. For a new case, go to Step 1. * Press [R/S] if you do not have an optional printer.			

Example:

If $s_x = 25000$ psi, $s_y = -5000$ psi, and $\tau_{xy} = 4000$ psi, compute the principal stresses and the maximum shear stress. Compute the normal stresses, where shear stress is maximum ($\Delta + 45^\circ$).

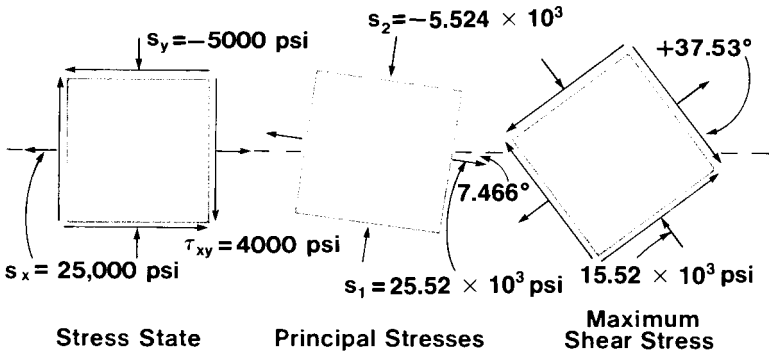

Keystrokes: (SIZE \geq 010)

[ENG] 3
 [XEQ] [ALPHA] MOHR [ALPHA]
 25000 [R/S]
 5000 [CHS] [R/S]
 4000 [R/S]
 [R/S] *
 [R/S] *
 [R/S] *
 [R/S] *
 7.466 [CHS] [ENTER+] 45 [+] [R/S]
 [R/S] *

Display:

SX=?
SY=?
SHEAR=?
S1=25.52E3
S2=-5.524E3
TAUMAX=15.52E3
 $\Delta = -7.466E0$
ARB $\Delta = ?$
TAU= 15.52E3
S= 10.00E3

* Press [R/S] if you do not have a printer.

STRAIN GAGE DATA REDUCTION

This program reduces data from rosette strain gage measurements. Given three strains it calculates the principal strains and the orientation of the principal axis. Given the modulus of elasticity of the material and Poisson's ratio the principal stresses can be generated. Using the principal stresses the stress configuration at an arbitrary angle can be found.

Initializing the program with **[XEQ] REC** causes the program to use correlations for a rectangular rosette. Initializing the program with **[XEQ] DELTA** causes the program to use correlations for a delta (equiangular) rosette.

Strain Gage Equations:

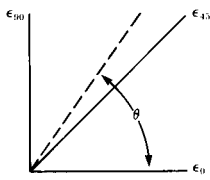
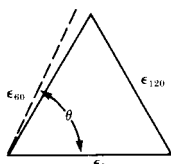
CONFIGURATION CODE	1	2
TYPE OF ROSETTE	RECTANGULAR	DELTA (EQUIANGULAR)
		
PRINCIPAL STRAINS: ϵ_1, ϵ_2	$\frac{1}{2} [\epsilon_0 + \epsilon_{90} \pm \sqrt{2(\epsilon_0 - \epsilon_{45})^2 + 2(\epsilon_{45} - \epsilon_{90})^2}]$	$\frac{1}{3} [\epsilon_0 + \epsilon_{120} + \epsilon_{60} \pm \sqrt{2(\epsilon_0 - \epsilon_{120})^2 + 2(\epsilon_{120} - \epsilon_{60})^2 + 2(\epsilon_{60} - \epsilon_0)^2}]$
CENTER OF MOHR CIRCLE $\frac{s_1 + s_2}{2}$	$\frac{E(\epsilon_0 + \epsilon_{90})}{2(1 - \nu)}$	$\frac{E(\epsilon_0 + \epsilon_{120} + \epsilon_{60})}{3(1 - \nu)}$
MAXIMUM SHEAR STRESS: τ_{max}	$\frac{E}{2(1 + \nu)} \sqrt{2(\epsilon_0 - \epsilon_{45})^2 + 2(\epsilon_{45} - \epsilon_{90})^2}$	$\frac{E}{3(1 + \nu)} \sqrt{2(\epsilon_0 - \epsilon_{120})^2 + 2(\epsilon_{120} - \epsilon_{60})^2 + 2(\epsilon_{60} - \epsilon_0)^2}$
ORIENTATION OF PRINCIPAL STRESSES λ	$\frac{1}{2} \tan^{-1} \left[\frac{2\epsilon_{45} - \epsilon_0 - \epsilon_{90}}{\epsilon_0 - \epsilon_{90}} \right]$	$\frac{1}{2} \tan^{-1} \left[\frac{\sqrt{3}(\epsilon_{60} - \epsilon_{120})}{2(\epsilon_0 - \epsilon_{120} - \epsilon_{60})} \right]$

where:

ϵ indicates a strain;

s_1 and s_2 are the principal normal stresses;

E is the modulus of elasticity;

ν is Poisson's ratio.

Reference:

Beckwith, T. G.; Buck, N.L.; *Mechanical Measurements*, Addison-Wesley, 1969.

				SIZE: 010
STEP	INSTRUCTIONS	INPUT	FUNCTION	DISPLAY
1	Initialize for rectangular or delta rosette.		[XEQ] REC [XEQ] DELTA	e0=? e0=?
2	Key in strain at zero degrees.	ϵ_0	[R/S]	e45=? or e60=?
3	Key in strain at 45 degrees for rectangular rosette, or strain at 60 degrees for delta rosette.	ϵ_{45} ϵ_{60}	[R/S] [R/S]	e90=? e120=?
4	Key in strain at 90 degrees for rectangular rosette or strain at 120 degrees for delta rosette and calculate principal strains and orientation of principal strains.	ϵ_{90} ϵ_{120}	[R/S] [R/S] [R/S]* [R/S]*	e1= e2= Δ =
5	For additional strain calculations, go to Step 1.			
6	For calculation of principal stresses, key in modulus of elasticity and Poisson's ratio.	E ν	[R/S]* [R/S] [R/S]* [R/S]* [R/S]*	E=? POISSON=? S1= S2= TAUMAX= Δ =
7	For stress configuration at an arbitrary orientation angle, key in angle.	ARB Δ	[R/S]* [R/S] [R/S]*	ARB Δ =? TAU= S=
8	Go to Step 7 for other arbitrary orientations. Go to Step 1 for a new case. * Press [R/S] if you do not have an optional thermal printer.			

Example 1:

A rectangular rosette measures the strains below. What are the principal strains and principal stresses?

$$\epsilon_0 = 90 \times 10^{-6} \qquad \epsilon_{45} = 137 \times 10^{-6} \qquad \epsilon_{90} = 305 \times 10^{-6}$$

$$\nu = 0.3 \qquad E = 30 \times 10^6 \text{ psi}$$

Keystrokes: (SIZE \geq 010)

Display:

[ENG] 3
 [XEQ] [ALPHA] REC [ALPHA]
 90 [EEX] [CHS] 6 [R/S]
 137 [EEX] [CHS] 6 [R/S]
 305 [EEX] [CHS] 6 [R/S]

e0=?
 e45=?
 e90=?
 e1=320.9E-6

Keystrokes:

R/S *
R/S *
R/S *
 30 **EEX** 6 **R/S**
 .3 **R/S**
R/S *
R/S *
R/S *

Display:

e2=74.14E-6
 $\Delta = 14.69E0$
E=?
POISSON=?
S1=11.31E3
S2=5.618E3
TAUMAX=2.847E3
 $\Delta = 14.69E0$

Example 2:

An equiangular rosette measures the strains below. What are the principal strains and stresses?

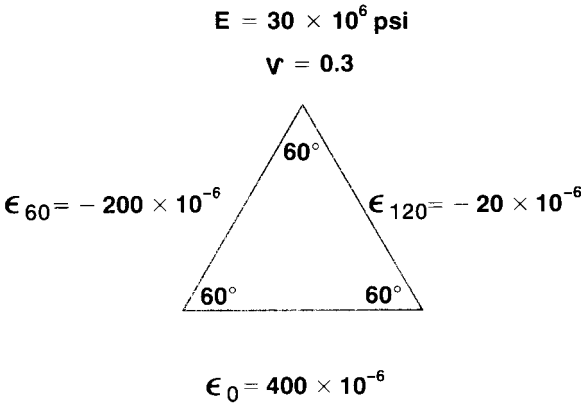

Keystrokes: (SIZE ≥ 010)

ENG 3
XEQ **ALPHA** DELTA **ALPHA**
 400 **EEX** **CHS** 6 **R/S**
 200 **CHS** **EEX** **CHS** 6 **R/S**
 20 **CHS** **EEX** **CHS** 6 **R/S**
R/S *
R/S *
R/S *
 30 **EEX** 6 **R/S**
 .3 **R/S**

Display:

e0=?
e60=?
e120=?
e1=415.5E-6
e2=-295.5E-6
 $\Delta = -8.498E0$
E=?
POISSON=?
S1=10.78E3

* Press **R/S** if you do not have an optional printer.

Keystrokes:**R/S** ***R/S** ***R/S** ***Display:****S2=-5.633E3****TAUMAX=8.204E3****Δ =-8.498E0**

SODERBERG'S EQUATION FOR FATIGUE

This program will calculate the sixth variable from the other five values in Soderberg's equation. It is useful in sizing parts for cyclic loading, calculating factors of safety, choosing materials based on size constraints and estimating the fatigue resistance of available parts. Soderberg's equation is graphically represented in figure 1.

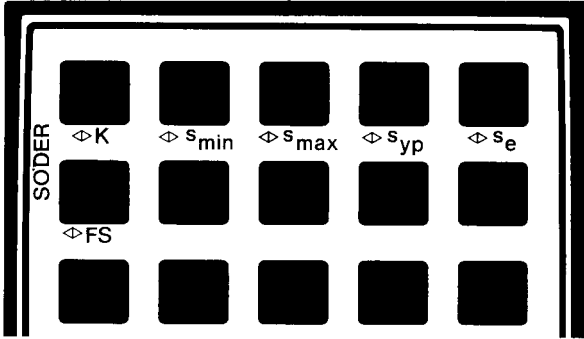

Equations:

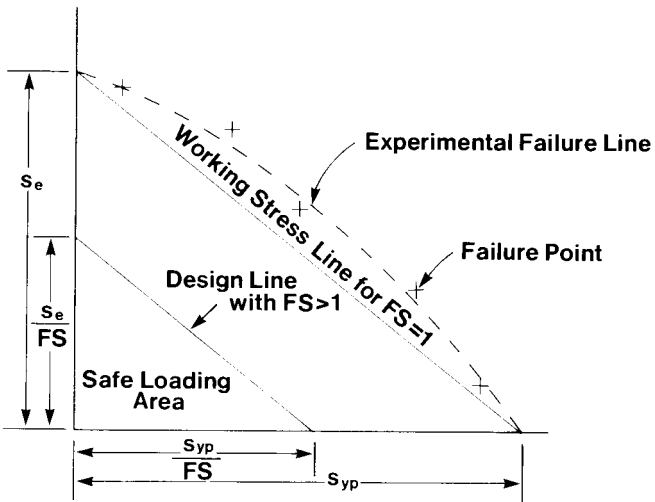

**Working Stress Diagram
Figure 1**

$$\frac{s_{yp}}{FS} = \frac{s_{max} + s_{min}}{2} + K \left(\frac{s_{yp}}{s_e} \right) \left(\frac{(s_{max} - s_{min})}{2} \right)$$

where:

s_{yp} is the yield point stress of the material;

s_e is the material endurance stress from reversed bending tests;

K is the stress concentration factor for the part;

FS is the factor of safety ($FS \geq 1.00$);

s_{max} is the maximum stress;

s_{min} is the minimum stress.

Reference:

Spotts, M. F.; *Design of Machine Elements*, Prentice-Hall, Inc., 1971.

Baumeister, T.; *Marks Standard Handbook for Mechanical Engineers*, McGraw-Hill Book Company, 1967.

Remarks:

This implementation of Soderberg's equation is for ductile materials only.

Values of stress concentration factors and material endurance limits may be found in the referenced sources.

In the presence of corrosive media, or for rough surfaces, fatigue effects may be much more significant than predicted by this program.

				SIZE: 007
STEP	INSTRUCTIONS	INPUT	FUNCTION	DISPLAY
1	Initialize program.		<input checked="" type="checkbox"/> XEO SODER	RDY A-F
2	Key in five of the following: stress concentration factor, minimum stress, maximum stress, material yield point, material endurance limit, factor of safety.	K s_{min} s_{max} s_{yp} s_e FS	<input type="checkbox"/> A <input type="checkbox"/> B <input type="checkbox"/> C <input type="checkbox"/> D <input type="checkbox"/> E <input type="checkbox"/> F	K= SMIN= SMAX= SYP= Se= FS=
3	Calculate unknown values: stress concentration factor, or minimum stress, or maximum stress, or material yield point, or material endurance limit, or factor of safety.		<input type="checkbox"/> A <input type="checkbox"/> B <input type="checkbox"/> C <input type="checkbox"/> D <input type="checkbox"/> E <input type="checkbox"/> F	K= SMIN= SMAX= SYP= Se= FS=
4	For a new case, go back to Step 2 and change any or all of the inputs.			

54 Soderberg's Equation for Fatigue

Example:

What is the maximum permissible cyclic stress for a part if the minimum stress is 4000 pounds per square inch?

$$s_{yp} = 70000 \text{ psi}$$

$$s_e = 25000 \text{ psi}$$

$$K = 1.25$$

$$FS = 2.0$$

Keystrokes: (SIZE \geq 007)

Display:

■ **FIX** 2

XEQ **ALPHA** SODER **ALPHA**

4000 **B**

70000 **D**

25000 **E**

1.25 **A**

2 **F**

C

RDY A-F

SMIN=4,000.00

SYP=70,000.00

Se=25,000.00

K=1.25

FS=2.00

SMAX=17,777.78

If s_{max} is changed to 20000 pounds per square inch, what will s_e have to be?

20000 **C** **E**

Se=30,434.78

If s_e is changed back to 25000 pounds per square inch, what will the factor of safety be?

25000 **E** **F**

FS=1.75

RPN VECTOR CALCULATOR

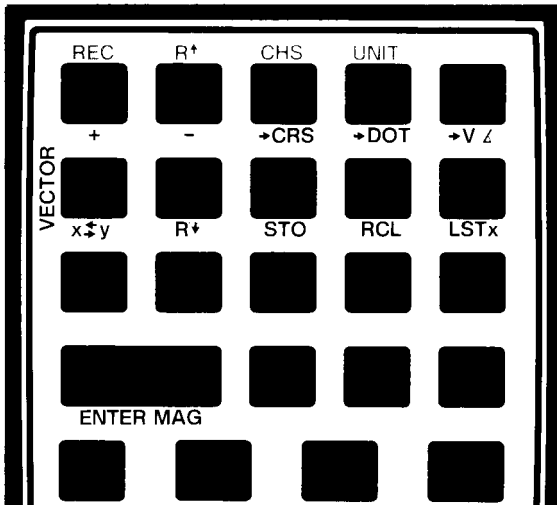

Execution of **VECTOR** transforms the HP-41C into a four-register-stack, RPN, vector calculator. Vectors are displayed in the magnitude/angle format. The character “ Δ ” is used to separate the magnitude and angle in the display. The top two rows of keys are redefined as vector add, subtract, cross product, dot product, angle subtraction, X exchange Y, roll down, store, recall, LAST X, rectangular display, roll up, change sign and unit vector. In addition, **ENTER** is used to separate between magnitude and angle in vector entry and **R/S** is used to terminate vector entry. These operations are analogous to their scalar counterparts in the HP-41C with the following exceptions:

1. Cross product, dot product, vector angle subtraction, and rectangular display do not change the content of the stack or LAST X. They modify the display only.
2. Store and recall apply to only one vector register.
3. When a vector is terminated using **R/S** only one copy is generated in the vector stack.

Vector Calculator Data Structure

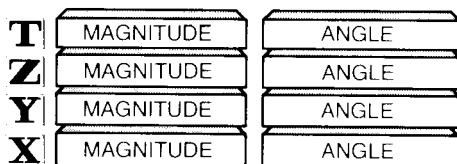

STEP	INSTRUCTIONS	INPUT	FUNCTION	SIZE: 016 DISPLAY
1	Initialize program.		XEQ VECTOR	0.00Δ0.00*
2	Key in magnitude.	MAG	ENTER	MAG
3	Key in angle.	ANGLE	R/S	MAGΔANGLE
4	Perform any of the following operations: terminate vector entry or add vectors or subtract vectors or take cross product or take dot product or find acute angle between vectors or exchange vectors or roll vector stack down or store vector or recall vector or recall LAST X vector or display vector in rectangular form or roll vector stack up or change sign of vector or change to unit vector.		R/S A B C D E F G H I J A B C D	MAGΔANGLE MAGΔANGLE MAGΔANGLE Y × X = DOT= VΔ= MAGΔANGLE MAGΔANGLE MAGΔANGLE MAGΔANGLE MAGΔANGLE MAGΔANGLE HORZ↑VERT MAGΔANGLE MAGΔANGLE MAGΔANGLE
5	To key in another vector, go to Step 2. To perform another operation, go to Step 4. * Assumes FIX 2 display setting.			

Example 1:

Resolve the following three loads along a 175 degree line.

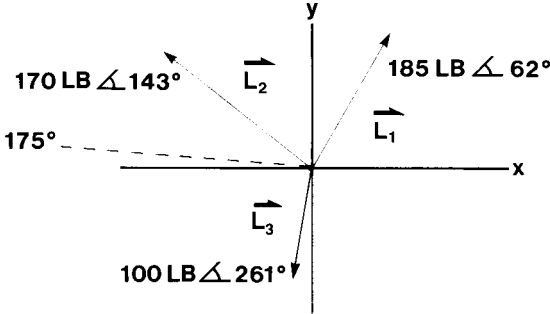

Keystrokes: (SIZE ≥ 016)

Display:

First add L₁ and L₂.

█	FIX	2		
XEQ	ALPHA	VECTOR	ALPHA	0.00Δ0.00
185	ENTER ↵	62	R/S	185.00Δ62.00
170	ENTER ↵	143	A	270.12Δ100.43

Add L₃.

100	ENTER ↵	261	A	178.94Δ111.15
-----	----------------	-----	----------	---------------

Resolve vector along 175 degree line by using dot product.

1	ENTER ↵	175	D	DOT=78.86
---	----------------	-----	----------	------------------

If L₃ is doubled, what is the resolution along the 175 degree line? Take advantage of vector store, vector recall and the fact that L₃ is in vector LAST X.

Store the 175 degree vector.

H	1.00Δ175.00
----------	-------------

Move the current sum back to the display register of the vector stack with vector roll down.

G	178.94Δ111.15
----------	---------------

Get L₃ from vector LAST X.

J	100.00Δ261.00
----------	---------------

Add.

A	105.22Δ139.66
----------	---------------

Recall 175 degree vector.

I	1.00Δ175.00
----------	-------------

Use dot product to resolve the new sum along the 175 degree vector.

D	DOT=85.83
----------	------------------

Example 2:

What is the moment at the shaft of the crank pictured below? What is the reaction force transmitted along the member?

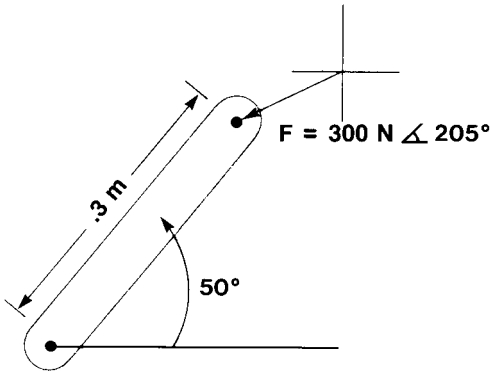

Keystrokes: (SIZE ≥ 016)

Display:

Moment by cross product ($V_1 \times F$).

FIX 2 **XEQ** **ALPHA** VECTOR

ALPHA

0.00 ∠ 0.00

.3 **ENTER** 50 **R/S**

0.30 ∠ 50.00

300 **ENTER** 205 **C**

Y*X=38.04

Resolution along the shaft by dot product.

F

0.30 ∠ 50.00

D

1.00 ∠ 50.00

D

DOT=-271.89

APPENDIX A
Program Data

PROGRAM	# REGS TO COPY	DATA REGISTERS	FLAGS	DISPLAY FORMAT	SUBPROGRAMS CALLED
Section	82	00 = ΣA 01 = ΣM_y 02 = ΣM_x 03 = ΣI_x 04 = ΣI_y 05 = ΣI_{xy} 06 = $(x_{i+1} - x_i)$ 07 = $(y_{i+1} - y_i)$ 08 = $(x_{i+1} + x_i)$ 09 = $(y_{i+1} + y_i)$ 10 = x_i 11 = y_i 12 = x_{i+1} 13 = y_{i+1} 14 = Scratch 15 = Scratch 16 = Counter	00-First Input 01-Used 21-Print 27-User Mode	ENG 3	SIZE? ATANY/X

Beams	93	00 = MIN 01 = MAX 02 = Plot 03 = E*1 04 = Σ of load affects 05 = Plot 06 = x 07 = Scratch/Plot 08 = Scratch/Plot 09 = L 10 = XINC 11 = Beam type (1-4) 12 = Counter copy 13 = Counter copy 2 14 = Scratch 15 = Scratch 16 = Scratch 17 = Scratch 18 = Scratch 19 = Counter 20 = nnn = Loads	00-Edit 01-Angle/Shear 02-Shear 27-User Mode	ANY	SIZE? PRPLOT *W *P *L *M
Continuous Beams	54	See Beams 20 – nnn = Loads and Spans	00-Edit 01-Set 02-Cleared 21-Print 27-User Mode	ENG 3	SIZE? *B *W *P *L *M

Columns	33	00 = P_e	22-Input/Output 27-User Mode	ANY	SIZE?
		01 = A			
		02 = a			
		03 = c			
		04 = S_{yp}			
		05 = E			
		06 = FS			
		07 = K			
		08 = L			
		09 = I			
		10 = Scratch			
		11 = Scratch			

Mohr Circle Analysis	27	00 = E	21-Print 27-User Mode	ANY	SIZE? ATANY/X
		01 = ν			
		02 = 2Δ			
		03 = s_x			
		04 = s_y			
		05 = Shear			
		06 = Center of Mohr Circle			
		07 = Scratch			
		08 = Scratch			
		09 = Scratch			

Strain Gage	35	00 = E	00-Delta	ANY	SIZE?
Data		01 = ν	21-Print		ATANY/X
Reduction		02 = 2Δ	27-User Mode		*MO
		03 = Scratch			
		04 = Scratch			
		05 = Shear			
		06 = Center of Mohr Circle			
		07 = ϵ_0			
		08 = $\epsilon_{.15}/\epsilon_{.60}$			
		09 = $\epsilon_{.90}/\epsilon_{.120}$			
Soderbergs	27	00 = Control	27-User	ANY	SIZE?
Equation for		01 = K			
Fatigue		02 = S_{min}			
		03 = S_{max}			
		04 = S_{yp}			
		05 = S_e			
		06 = FS			

RPN Vector Calculator	60	00 = Pointer to x_r 01 = Pointer to x_Δ 02 = Last x_r 03 = Last x_Δ 04 = Scratch 05 = Register _r 06 = Register _{Δ} 07 = Scratch 08 = Stack _r 09 = Stack _{Δ} 10 = Stack _r 11 = Stack _{Δ} 12 = Stack _r 13 = Stack _{Δ} 14 = Stack _r 15 = Stack _{Δ}	22-Input	ANY	SIZE?
--------------------------	----	--	----------	-----	-------



1000 N.E. Circle Blvd., Corvallis, OR 97330

For additional sales and service information contact
your local Hewlett-Packard Sales Office or call (800)
547-3400. (In Oregon, Alaska, or Hawaii, call (503)
758-1010.)