

**9865A CASSETTE MEMORY**

**HEWLETT-PACKARD CALCULATOR PRODUCTS DIVISION**  
P.O. Box 301, Loveland, Colorado 80537, Tel. (303) 667-5000  
Rue du Bois-du-Lan 7, CH-1217 Meyrin 2, Geneva, Tel. (022) 41 54 00

Copyright by Hewlett-Packard Company 1972

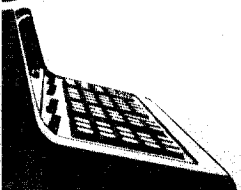

# TABLE OF CONTENTS

## CHAPTER 1. GENERAL INFORMATION

### INTRODUCTION

Supplied Equipment . . . . .	1-1
Specifications . . . . .	1-1
The Tape Cassette . . . . .	1-1
Instrument Identification . . . . .	1-2
Initial Inspection . . . . .	1-3
Service Contracts . . . . .	1-3

### INSTALLATION

Power Requirements . . . . .	1-3
Grounding Requirements . . . . .	1-3
Setting the Line Voltage . . . . .	1-4
Changing the Fuse . . . . .	1-4
Cassette Memory Installation . . . . .	1-6
The Cassette Control Block . . . . .	1-6
Cassette Memory Select Code . . . . .	1-6
Electrical Inspection . . . . .	1-8

## CHAPTER 2. CASSETTE MEMORY OPERATION

Front Panel Controls . . . . .	2-1
The LINE Switch . . . . .	2-1
The Tape Release Lever . . . . .	2-1
The REWIND Button . . . . .	2-1
Loading Tape . . . . .	2-2
The Protect Tabs . . . . .	2-2
Storing Tape Cassettes . . . . .	2-2

## CHAPTER 3. INSTRUMENT MAINTENANCE

Cleaning the Tape Head . . . . .	3-1
Changing the Front Panel Lamp . . . . .	3-2

## APPENDIX

Technical Specifications	
--------------------------	--

## PREFACE

This manual contains installation and general user-instructions for the Model 9865A Cassette Memory.

If you're using the cassette memory with a 9830 Calculator, all operating instructions are contained in the 9830 Operating and Programming Manual. However, if a 9810 or 9820 Calculator is used, a Cassette Memory Control Block (ROM Block) is required to enable your calculator to control the cassette memory: in that case, refer to the manual supplied with the ROM Block.

## INTRODUCTION

The -hp- Model 9865A Cassette Memory provides bulk storage of 9800-Series calculator program and data information. The cassette memory stores data or programs in individual files on a magnetic tape cassette. The quantity and the size of the files on each tape cassette are specified by the user. Stored data or program information may be recalled and utilized by the calculator; or data may be recalled, modified, and restored on the tape. Data files stored by the cassette memory are compatible with other 9800-Series calculator/cassette memory systems. For example, data files which are stored from a Model 10 Calculator can be loaded into a Model 20 Calculator.

See the operating manual supplied with your calculator's cassette control block for specific information on how to use the cassette memory.

The items listed below are supplied with the cassette memory.

**Table 1. Supplied Equipment**

DESCRIPTION	QUANTITY	-hp- PART NUMBER
Peripheral Manual	2	09865-90000
File Storage Forms	1 pad	09865-90001
Digital Tape Cassette	3	9162-0050
Select Code Labels	1 pkg.	7120-2940
Spare Fuses:		
.25A, 250V, Normal Blo	1	2110-0004
.5A, 250V, Normal Blo	1	2110-0012
Power Cords:		
AC Receptacle	1	8120-1378
Inter-Instrument	1	8120-1579
Interface Cable	1	09865-61603
Tape Head Cleaner	1	8500-1251
Cotton Applicators	100	8520-0023

**SUPPLIED  
EQUIPMENT**

Cassette memory specifications are listed in the APPENDIX at the back of this manual.

**SPECIFICATIONS**

The tape cassette recommended for use in the cassette memory is shown in Figure 1. This cassette is a precision unit and contains three-hundred feet of digital-quality, magnetic recording tape. These and other important characteristics make this tape cassette ideally suited for use in the cassette memory.

**THE TAPE  
CASSETTE**

**THE TAPE  
CASSETTE  
(continued)**

### INTRODUCTION

The -hp- tape cassette is available singly or in quantities at a reduced price. When ordering the tape cassette, specify -hp- part no. 9162-0050.

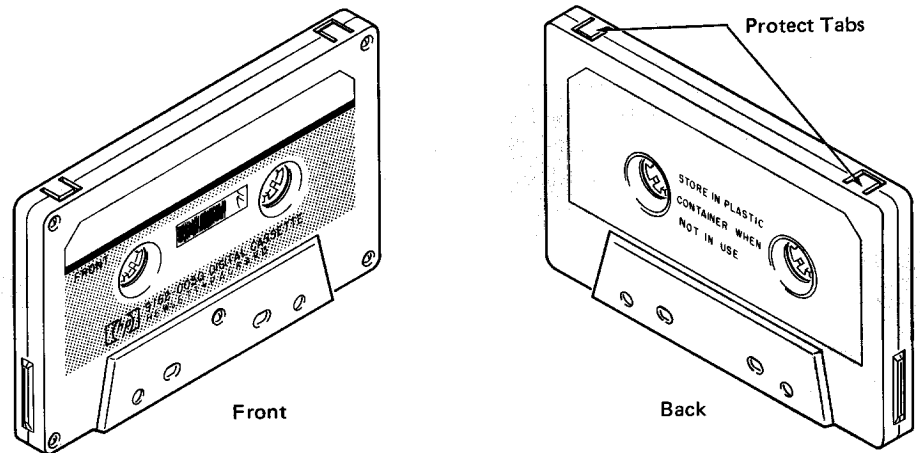

Figure 1. The Tape Cassette

Although many other available tape cassettes will initially work in the cassette memory, many of these products will not provide reliable cassette memory recordings. Also, since the use of some tape cassettes will actually damage the cassette memory, -hp- cannot ensure cassette memory operation if it is used with a tape cassette not supplied by -hp-.

For additional information on requirements for the tape cassette used in the cassette memory, contact your nearest -hp- Sales and Service Office; office locations are listed at the back of this manual.

#### CAUTION

THE CASSETTE MEMORY SERVICE WARRANTY DOES NOT COVER DAMAGE WHICH RESULTS FROM THE USE OF A TAPE CASSETTE NOT SUPPLIED BY HP.

## INTRODUCTION

The cassette memory was carefully inspected both mechanically and electrically before shipment. It should be free of marks or scratches and in perfect electrical order upon receipt. Carefully inspect the cassette memory for physical damage caused in transit; if there is any damage, file a claim with the carrier. If you wish to verify the electrical performance of the cassette memory, use the inspection procedure provided in the operating manual supplied with the cassette memory control block (ROM block) required for your calculator.

Service contracts are available for the cassette memory. For further information contact your nearest -hp- Sales and Service Office; locations are listed at the back of this manual.

## INSTALLATION

The cassette memory will operate within the voltage range of from 98 to 126 volts ac or 198 to 252 volts ac. The line frequency must be within 48 to 66 Hz. The cassette memory requires a maximum of 50 voltamps.

The voltage selector card (see Figure 2), located in the power module on the rear of the mainframe, selects a nominal operating voltage range of either 100V, 120V, 220V or 240V. A different fuse is required for operation in either the 100 – 120V or 220 – 240V range. Information on how to set the voltage selector and how to change fuses is presented in the following pages.

### CAUTION

DO NOT APPLY AC POWER TO THE CASSETTE MEMORY UNLESS THE LINE VOLTAGE SELECTOR IN THE POWER MODULE IS SET TO THE PROPER POSITION. DAMAGE TO THE CASSETTE MEMORY CAN RESULT FROM FAILURE TO OBSERVE THIS PRECAUTION.

To protect operating personnel, the NATIONAL ELECTRICAL MANUFACTURERS' ASSOCIATION (NEMA) recommends that the cassette memory cabinet be grounded. The cassette memory is equipped with a three-conductor power cable which, when connected to an appropriate receptacle, grounds the cabinet of the cassette memory. The center pin of the power cable connector is the ground connection.

INITIAL  
INSPECTION

SERVICE  
CONTRACTS

POWER  
REQUIREMENTS

GROUNDING  
REQUIREMENTS

**SETTING THE  
VOLTAGE  
SELECTOR****INSTALLATION**

Before connecting the power cord to the back of your calculator check the setting of the voltage selector card (see the following photos). The number visible indicates which voltage is set. If the card is set to the available power line voltage, you may skip the next instructions and go to Page 1-6.

To change the voltage setting, please refer to Figure 2 and the following 'NOTE'.

**CHANGING  
THE FUSE****NOTE**

For 120V operation use a .5 amp, Normal Blo fuse, -hp- Part No. 2110-0012.

For 240V operation use a .25 amp, Normal Blo fuse, -hp- Part No. 2110-0004.

To change the fuse, refer to Figure 2.

## INSTALLATION

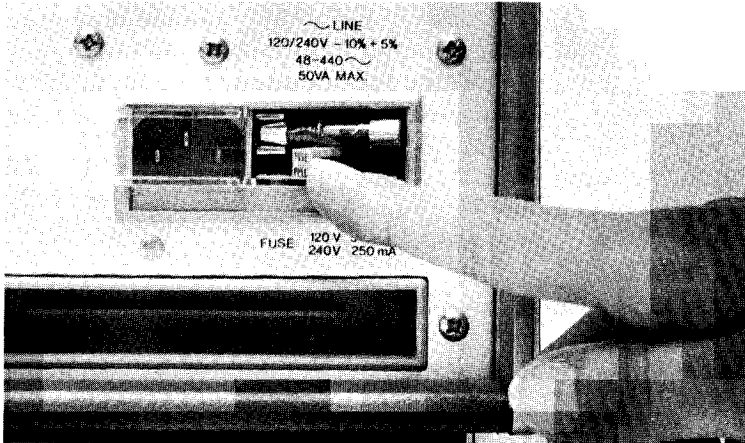

1. Slide the plastic window to the left and move the FUSE PULL lever to the left (removing the fuse).

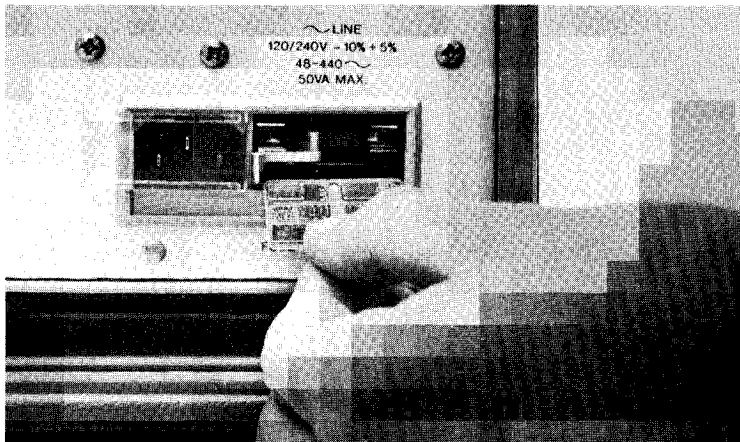

2. Position the line voltage selector such that the number indicating the required voltage setting is on the left.



3. Push the line voltage selector into the power module, insert the proper fuse, and slide the plastic window to the right.

**Figure 2. The Power Module**



### CASSETTE MEMORY INSTALLATION

## INSTALLATION

Figure 3 shows the cable interconnections required to connect the cassette memory to your 9800-Series calculator. The calculator-end of the interface cable can be plugged into any of the unused calculator I/O connectors. The inter-instrument power cord can be plugged into any unused calculator power receptacle; if all power receptacles are in use, utilize the other ac power cord supplied to connect the cassette memory to the ac power source.

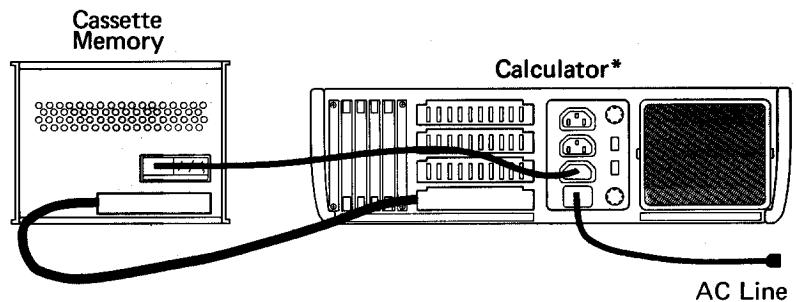

\* -hp- 9800-Series calculator with the proper cassette control block installed.

Figure 3. Cassette Memory Installation

### THE CASSETTE CONTROL BLOCK

An appropriate cassette control block (ROM block) must be plugged into your calculator before the cassette memory can be used in your 9800 system.\* Any -hp- Sales and Service Office can assist you in selecting the correct cassette control block for your calculator.

### CASSETTE MEMORY SELECT CODE

Since all calculator peripheral devices are connected in a 'party-line' fashion, each device must have a unique 'address' so that the calculator can specify which device should respond to which operation. The cassette memory's address (or select code) consists of a one-digit number and is determined by the circuitry on the interface card (see Figure 4). Each calculator-to-cassette memory operation must include the correct select code, thereby instructing the cassette memory interface card to respond to the operation while all other cards ignore it.

Each cassette memory is set to select code 5 at the factory. However, by using the following procedure, the cassette memory may be set to respond to any one of nine select codes.

\*The 9830 Calculator is an exception to this rule.

## INSTALLATION

### NOTE

The following procedure requires that you are familiar with printed circuit soldering techniques. If you require assistance, contact your nearest -hp- Sales and Service Office.

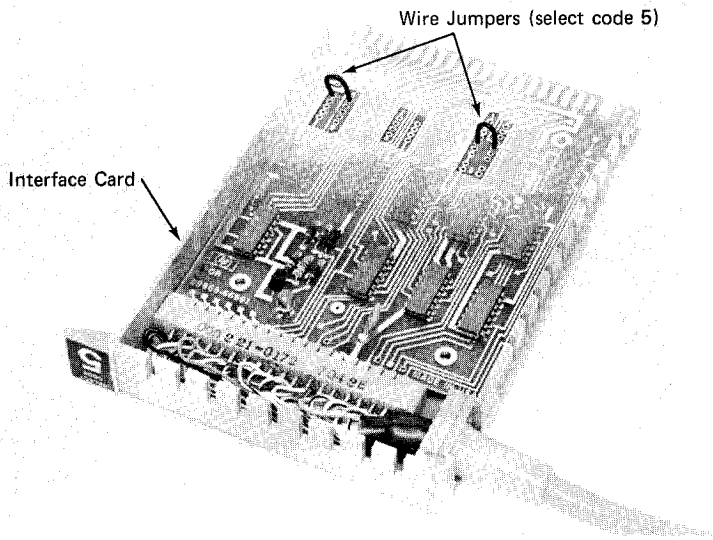

Figure 4a.

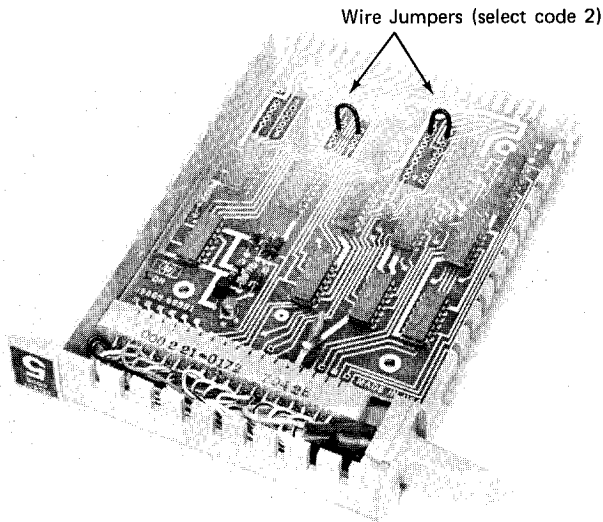

Figure 4b.

Figure 4. Changing the Select Code

CASSETTE MEMORY  
SELECT CODE  
(continued)

## INSTALLATION

1. Switch the calculator and the cassette memory OFF.
2. Disconnect the cassette memory interface card from the calculator. Remove the four screws located on the top of the card assembly; then, turn the card over and lift off the bottom cover.
3. Locate the two select code jumper wires (see Figure 4). Notice that each wire connects one set of holes on the interface card. The sets of holes are numbered 1 through 9 — each set corresponds to a specific select code number. Figure 4a shows the jumper wires set to select code 5, and Figure 4b shows the wires set to select code 2.
4. To change the select code, **both** wire jumpers must be unsoldered, inserted into the sets of holes which correspond to the desired select code, and resoldered.

### CAUTION

USE EXTREME CARE WHEN APPLYING HEAT TO THE CIRCUIT BOARD, AS THE BOARD CAN BE EASILY DAMAGED BY EXCESSIVE HEAT.

5. After resoldering both wire jumpers, carefully examine the board to ensure that excessive solder is not touching any of the adjacent holes. Remove any loose particles of solder from the board.
6. Reposition the board in the interface top cover and replace the bottom cover. Secure the bottom cover with the four screws removed in step 2.
7. Replace the Select Code Labels on the cassette memory mainframe and on the interface card with ones which indicate the new select code. A package of labels is supplied with your cassette memory.
8. Reconnect the interface card to the calculator and switch the calculator and the cassette memory ON. Verify that the desired select code is set by performing some cassette memory operations (or running a 'cassette memory program') which specify the new select code.

## ELECTRICAL INSPECTION

The procedure to verify the electrical performance of the cassette memory is contained in the operating information supplied with either your 9830 Calculator or the appropriate cassette control block.

The 'local' controls on the cassette memory are shown in Figure 5. Except for operation of the controls shown, all cassette memory operations are performed 'remotely', from the calculator.

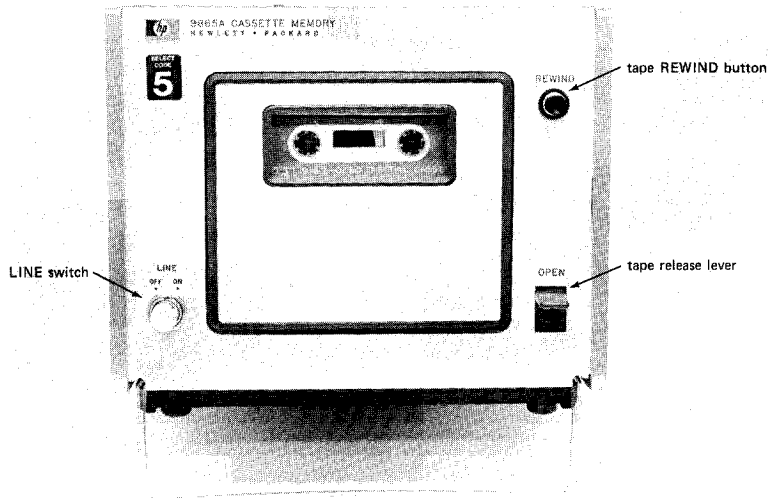

Figure 5. Controls on the Cassette Memory

The LINE switch controls the application of ac power to the cassette memory. The LINE switch lens is illuminated when power is applied to the instrument.

Pressing down on the Tape Release Lever causes the tape transport door to open. In general, the operator should not open the door unless the tape is positioned on clear-leader. If the cassette memory is rewinding or performing a remote operation when the door is opened, the operation will be immediately terminated and program operation will be halted.

Pressing REWIND causes the tape to completely rewind and automatically stop on the beginning clear-leader. However, if the tape is to be rewound and it is stopped on the ending clear-leader, REWIND must be pressed and held down for approximately two seconds to enable the tape to advance beyond the ending clear-leader.

#### NOTE

The REWIND button is disabled while the cassette memory is performing a remote operation. Also, the REWIND *operation* is disabled whenever the calculator is switched OFF.

#### FRONT PANEL CONTROLS

#### THE LINE SWITCH

#### THE TAPE RELEASE LEVER

#### THE REWIND BUTTON

## CASSETTE MEMORY OPERATION

### LOADING TAPE

To load tape into the cassette memory:

1. Open the tape transport door;
2. Insert the tape cassette into the transport cassette guides, such that the front of the cassette is facing toward the tape transport door; (be sure the tape cassette is firmly seated in the tape transport)
3. Close the door (see Figure 6).

After loading the cassette memory, press **REWIND** to ensure that the tape is fully rewound.



Figure 6. Loading Tape

### THE PROTECT TABS

The information recorded on a tape cassette can be protected from loss resulting from subsequent recording operations by removing both protect tabs on top of the cassette (see Figure 1 on Page 1-2). The cassette memory will immediately terminate any record operation attempted on a cassette which has both protect tabs removed.

### STORING TAPE CASSETTES

Each tape cassette is supplied with a plastic case; this should be used when storing the cassette, as a magnetic tape is delicate and can be easily damaged. Also, the tape should be fully rewound (on clear-leader) before it is removed from the cassette memory.

As with most magnetic tape products, the information stored in the tape cassette can be altered or destroyed by exposing the tape to a strong magnetic field, such as is produced by a bulk tape eraser, a toy magnet, or some metal-detection devices (e.g., equipment used at many airports). In some cases, the use of a steel container, such as an index box, will help protect the tape from magnetic fields.

As with most precision recording equipment, the cassette memory can be expected to provide trouble-free operation only if the user adheres to a scheme of regular preventative maintenance. The following tape-head cleaning procedure should be performed after every eight hours of cassette operation. Also, this procedure should be performed prior to making a 'permanent' cassette memory recording.

## CLEANING THE TAPE HEAD

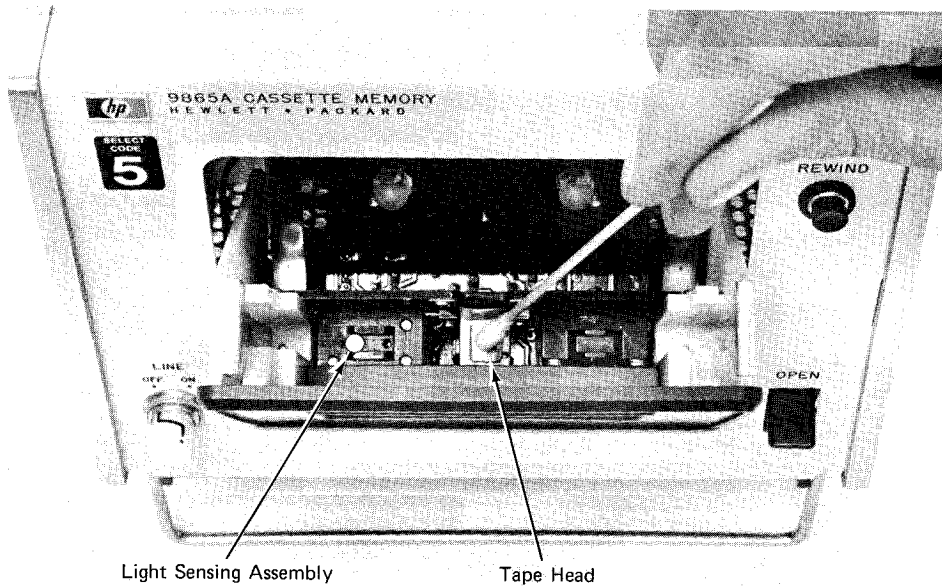

Figure 7. Cleaning the Tape Head

To clean the tape head:

1. Rewind and remove the tape cassette, then switch the cassette memory OFF.
2. Locate the tape head (see Figure 7). Remove any dust or other foreign material that has accumulated in the vicinity of the tape head.

### WARNING

READ ALL INFORMATION SUPPLIED WITH THE TAPE HEAD CLEANER BEFORE OPENING THE CONTAINER.

3. The tape head should be cleaned with a cotton applicator which has been dampened with head cleaning solution or denatured alcohol. It is sufficient to gently wipe the top of the head a few times, and then repeat wiping the head with a clean applicator.

**CLEANING THE  
TAPE HEAD**  
(continued)

**CAUTION**

DO NOT ALLOW THE CLEANING SOLUTION TO TOUCH THE TAPE-TRANSPORT DOOR OR THE LIGHT-SENSING ASSEMBLY (SEE FIGURE 7).

4. Close the tape-transport door after cleaning the tape head. A good practice is to close the door whenever the cassette memory is not in use, thus preventing dust from accumulating in the tape transport.

**CHANGING THE  
FRONT PANEL  
LAMP**

**WARNING**

BEFORE CHANGING THE LINE LAMP, BE SURE THE CASSETTE MEMORY IS DISCONNECTED FROM THE AC POWER SOURCE.

The LINE switch on the front panel of the cassette memory contains a neon light bulb. If the cassette memory functions normally, but the LINE switch fails to light, the bulb is probably burned out. To change the bulb, switch the cassette memory OFF and pull the switch lens straight out; the bulb will come out with the lens. Remove the old bulb and place the new one, -hp- Part No. 2140-0244, into the lens. Now reinstall the lens.

# APPENDIX

## SPECIFICATIONS

Size:	6-2/3" high X 8" wide X 11" deep (16.93 cm X 20.32 cm X 27.94 cm).
Weight:	11 pounds (5 kg).
Power Requirements:	98 – 126V ac or 198 – 252V ac, 48 to 66 Hz, 50 watts max.
Temperature Range:	0°C to 45°C (operating); –40°C to 75°C (storage, without tape cassette).
Humidity Range:	Up to 90% rel. Hum., non-condensing.
Search Speed:	Approximately 130 ft/min (26 in/sec).
Data Storage Capacity:*	> 6000 data registers. (See your Cassette Control Block Operating Manual for the program storage capacity).
Tape Life:*	> 1000 complete head passes.

\* When using the -hp- Tape Cassette.