

HEWLETT-PACKARD

HP 82165A

HP-IL/GPIO Interface

HP 82166A

HP-IL Converter

MANUAL SUPPLEMENT

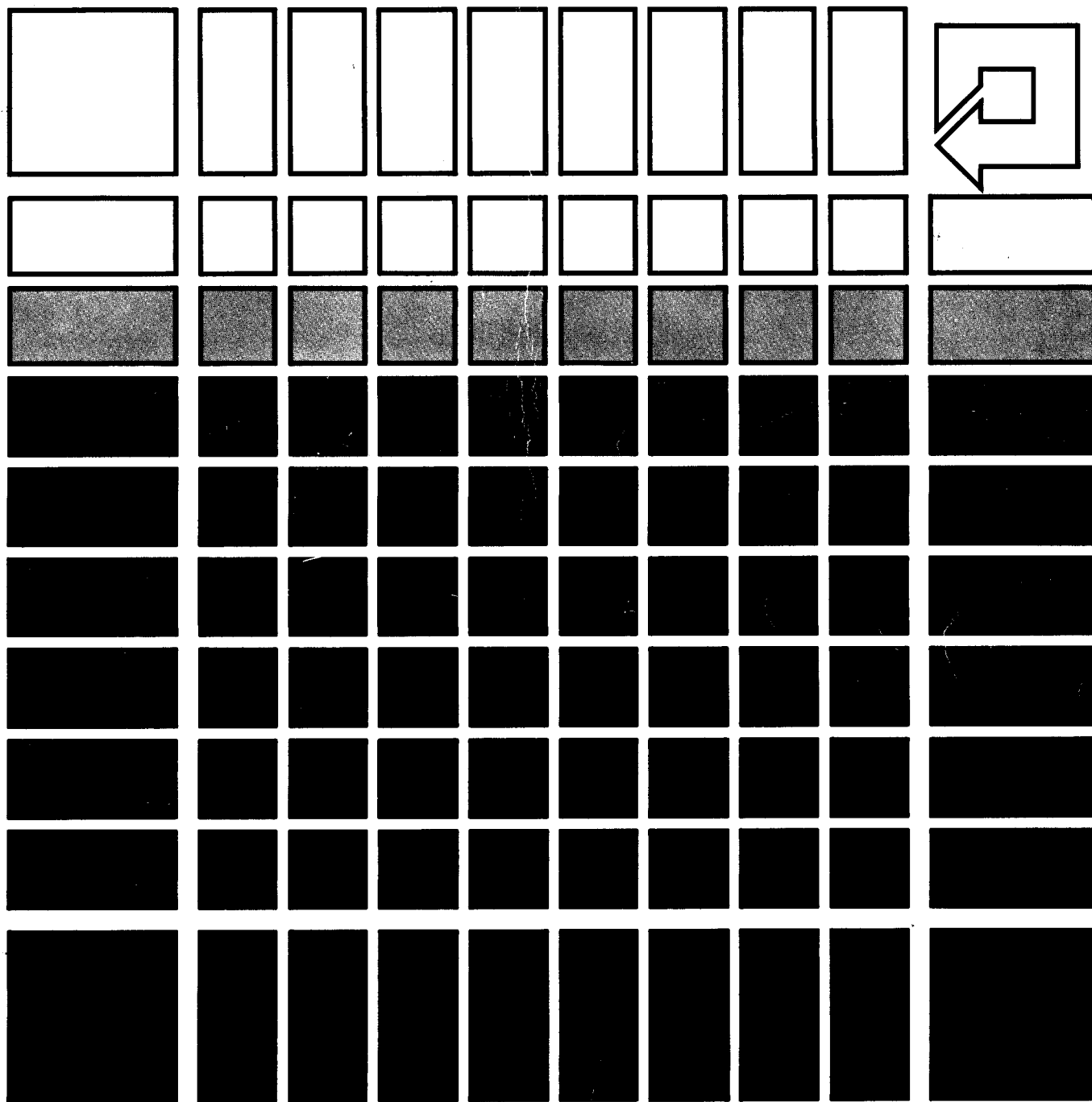



**HP 82165A
HP-IL/GPIO Interface**

**HP 82166A
HP-IL Converter**

Manual Supplement

October 1982

82165-90012

Contents

Introduction	2
Important Information for HP-41 Owners	2
The Transfer Buffer	3
The Status Byte and Service Requests	3
The Handshake Lines	4
Additional Information	7

Introduction

The information in this supplement applies to the HP 82165A HP-IL/GPIO Interface and to the HP 82166A HP-IL Converter. Additional technical information not contained in the owner's manuals is provided here to assist in the proper application of these two products. You should refer to the owner's manuals supplied with these products for other operating information. In addition, this supplement provides corrections to the manuals.

Because these two products are nearly identical functionally, the information in this supplement refers to both unless explicitly stated otherwise. The term "converter" refers to both products throughout this supplement. Page references to the *HP 82166A HP-IL Converter Technical Manual* (part number 82166-90002, dated November 1981) will be given when appropriate followed by the corresponding page references to the *HP 82165A HP-IL/GPIO Interface Owner's Manual* (part number 82165-90002, dated February 1982) contained in parentheses—for example, page 12 (14). If information contained herein conflicts with information in the owner's manuals, this supplement takes precedence.

Important Information for HP-41 Owners

The HP 82160A HP-IL Module for the HP-41 Handheld Computer does not by itself provide functions to access the converter control registers. This means that the converter can be used only in its power-on default operating mode: eight-bit bidirectional data bus, full three-line handshake, positive (high-true) data bus logic, negative (low-true) handshake line logic, and service request for manual service request only. Additional operations that cannot be performed with the HP-IL module alone are the converter/HP-IL test, the clear transfer buffer command, and operation using service requests. This default operation mode is sufficient for many applications.

The HP 82183A Extended I/O Module (available March 1983), when used with the HP-IL module, provides the additional functions needed to access the other converter operating modes for those applications that require them. While it was not designed with this purpose in mind, the HP-IL Development Module, part number 00041-15043 (available December 1982), also contains a set of functions which can provide this extra capability when used with the HP-IL module.

Additional information regarding the use of the HP-41 and the HP-IL module with the converter is contained in Appendix D, "Using the HP-41 As a Controller," page 33 (34) ^{of ~~the~~ manual} as well as in the HP-IL module owner's manual. Information on the extended I/O module and the HP-IL development module can be found in their respective owner's manuals.

*data lines : 1 + 5V (TTL High) 2 — input or output
 % 0.7V (TTL Low) — input or output*

The Transfer Buffer

All the data that passes through the converter is stored temporarily in the transfer buffer. There is only one transfer buffer. It can contain data bytes being sent from HP-IL to the GPIO device or bytes being sent from the GPIO device to HP-IL, but not both simultaneously. If the buffer contains data received from the GPIO device and HP-IL performs a write operation to the converter, the data from the GPIO device will be lost. If the buffer has data from HP-IL, the GPIO device cannot write into the converter buffer since the RDYO line will not go true. This will be a problem only in applications where data must pass in both directions. Loss of data from GPIO can be avoided by reading the converter status before writing data from HP-IL into the buffer.

Although the transfer buffer consists of 32 registers, it will never hold 32 bytes of data. If the GPIO device is not accepting data, HP-IL can put 30 bytes of data into the transfer buffer. The 31st byte will be held by the converter and not retransmitted on the loop. When the GPIO device accepts some data, thereby making room in the buffer, this byte will be retransmitted on the loop (and loaded into the buffer), and the transmission of data can continue. If the GPIO device does not respond, the converter will hold the 31st byte indefinitely or until the controller times out. In this situation, the controller normally aborts the data transmission and displays an error message.

If the GPIO device is sending data to HP-IL, the converter buffer can contain up to 31 bytes of data from the GPIO device. In this condition, the RDYO line will not go true, so the GPIO device cannot write any more data into the converter. When HP-IL reads one or more bytes from the buffer, the RDYO line will once again go true, and the GPIO device can continue sending its data.

Information on the transfer buffer is found on page 6 (8), 11-13 (13-15), 16 (18), and 27-28 (28-29).

The Status Byte and Service Requests

An application that only sends data to the GPIO device may not require status information. If the GPIO device is faster than the sourcing device, the buffer will never have more than one or two bytes in it. The data transmission will take place without interruption at the rate of the sourcing device. On the other hand, if the GPIO device is slower than the sourcing device, the buffer may fill up. When this occurs and another byte is sourced, the converter simply holds up the loop transfer until the GPIO device accepts a byte, thereby making room in the buffer. In this case, the data transmission takes place with brief interruptions at the rate of the GPIO device.

When the GPIO device must send data to HP-IL, when data must flow both ways, or when I/O operations need to be interleaved, it is important to know the converter status so the controller can determine what needs to be done next. Most of the status indications are related to the transfer buffer.

If the decimal value of the returned status byte is 1, the converter is ready to receive data from HP-IL. This could mean the buffer is empty, or it could mean that the buffer still contains some data from HP-IL which is flowing steadily out to the GPIO device and more data can be accepted from HP-IL immediately. If the status value is 8, the buffer has some data from HP-IL, but the data is not flowing out to the GPIO device. This usually means that the GPIO device did not set the RDYI handshake line true. If the DAVO timeout option is enabled in the converter control registers, it could mean that although the RDYI line was true, the GPIO device did not accept the data byte by driving the DACI line true before the timeout period expired.

However, in most situations the converter returns a value of 1 even though the GPIO device is not taking the data. If the Interface Clear message is sent to the converter just prior to reading its status, it will update the status internally and return the correct value, either 8 or 1. For example, the HP-41 sends this message by executing the `[STOPIO]` function. Note that the Interface Clear message does not change the data in any way.

When data is being sent from HP-IL to GPIO, the status will always be either 1 or 8. Even though the buffer is full (30 bytes), the buffer full status value of 4 will *not* be indicated. Furthermore, data cannot be sent from the GPIO device while data from HP-IL is in the buffer since the RDYO line will not go true, so that the buffer busy status value of 16 will also never be generated.

A status value of 2 indicates that the buffer contains some data from the GPIO device and is ready to send it to HP-IL. When the status byte is 6, the transfer buffer has received 31 bytes of data from the GPIO device and will accept no more until some of the data is read out of the buffer by HP-IL.

On the HP 82165A HP-IL/GPIO Interface only, the front panel MSRQ (manual service request) key simply connects the $\overline{\text{MSRQ}}$ line (pin 13) to ground while it is pressed. On both products, the status value of 32 (Manual Service Request) is returned only if status is read while the $\overline{\text{MSRQ}}$ line is grounded. The Manual Service Request condition is not automatically retained until the status is read.

Each of the status conditions (as well as the Manual Service Request condition) can be used to generate a service request on the loop (sets bit C0 in Data and Identify messages). The power-on default condition is that Manual Service Request will generate a service request, while the status conditions do not. This default can be changed by setting or clearing the appropriate bits in control register R00. If bit 7 is set to enable status service requests, either bit 5 can be set to enable *any* change in status to cause a service request, or bit 5 can be left clear and combinations of bits 4 through 0 can be set to cause *particular* status conditions to send a service request.

Information on the converter status and service requests is found on pages 12-13 (14-15) and 27-28 (28-29).

The Handshake Lines

Before the operation of the handshake lines can be thoroughly understood, some familiarity with the microprocessor program structure is needed. All of the I/O operations of the converter are done by polling rather than by interrupts. The converter's internal program simply runs in a continuous loop checking to see if an HP-IL or GPIO operation needs to be done. The operation of this program loop is the same regardless of whether the converter is the talker or a listener on HP-IL. Only the transfer buffer and the handshake lines affect this program loop. (The program is illustrated on the following page.)

At the top of the loop, HP-IL is polled to see if a message has been received. If it has, the appropriate action is taken, which might include retransmitting the received message on the loop, or perhaps sending a data byte from the transfer buffer to the loop.

Next, the microprocessor checks to see if there is data in the buffer waiting to be sent to the GPIO device. If there is, the state of the RDYI line is checked. If the GPIO device is not ready (RDYI false), the internal program simply goes back to the top of the loop. If the GPIO device is ready (RDYI true), the converter sends the byte on the data bus lines and sets the DAVO line true. Then the converter waits until the GPIO device accepts the data by driving the DACI line true. When this occurs, the microprocessor goes back to the top of the loop and continues.

If the GPIO device does not respond by driving the DACI line true, the converter will wait indefinitely. This means that HP-IL will not function during this time, since the converter cannot respond to a received message until it gets back to the top of the loop. If necessary, the DAVO timeout option can be enabled to handle this situation. By appropriate settings for control register R02-3,0 and control register R03, the converter can be made to wait only the specified amount of time in this state and then remove the data from the data bus lines and drive the DAVO line false if the GPIO device has not responded. The data byte is retained in the converter buffer and the converter program will attempt to output the byte again the next time through the loop.

Use the following information instead of the output (HP-IL \rightarrow GPIO) timing numbers in the table on page 19 (20). The following paragraphs provide the appropriate information for interfacing in any one of the four output handshake modes. Refer to the diagrams on page 15 (17).

In the full handshake mode (default), the GPIO device may set the RDYI line true at any time to indicate that it is ready to receive data. The GPIO device must hold the RDYI line true until the converter responds by driving the data bus lines and the DAVO line true. If there is no data in the buffer, the GPIO device should simply wait until there is. If there is data in the buffer, the delay from RDYI true to DAVO true may range from about 250 microseconds to 1 millisecond. As soon as the DAVO line is true, the GPIO device may accept the data and

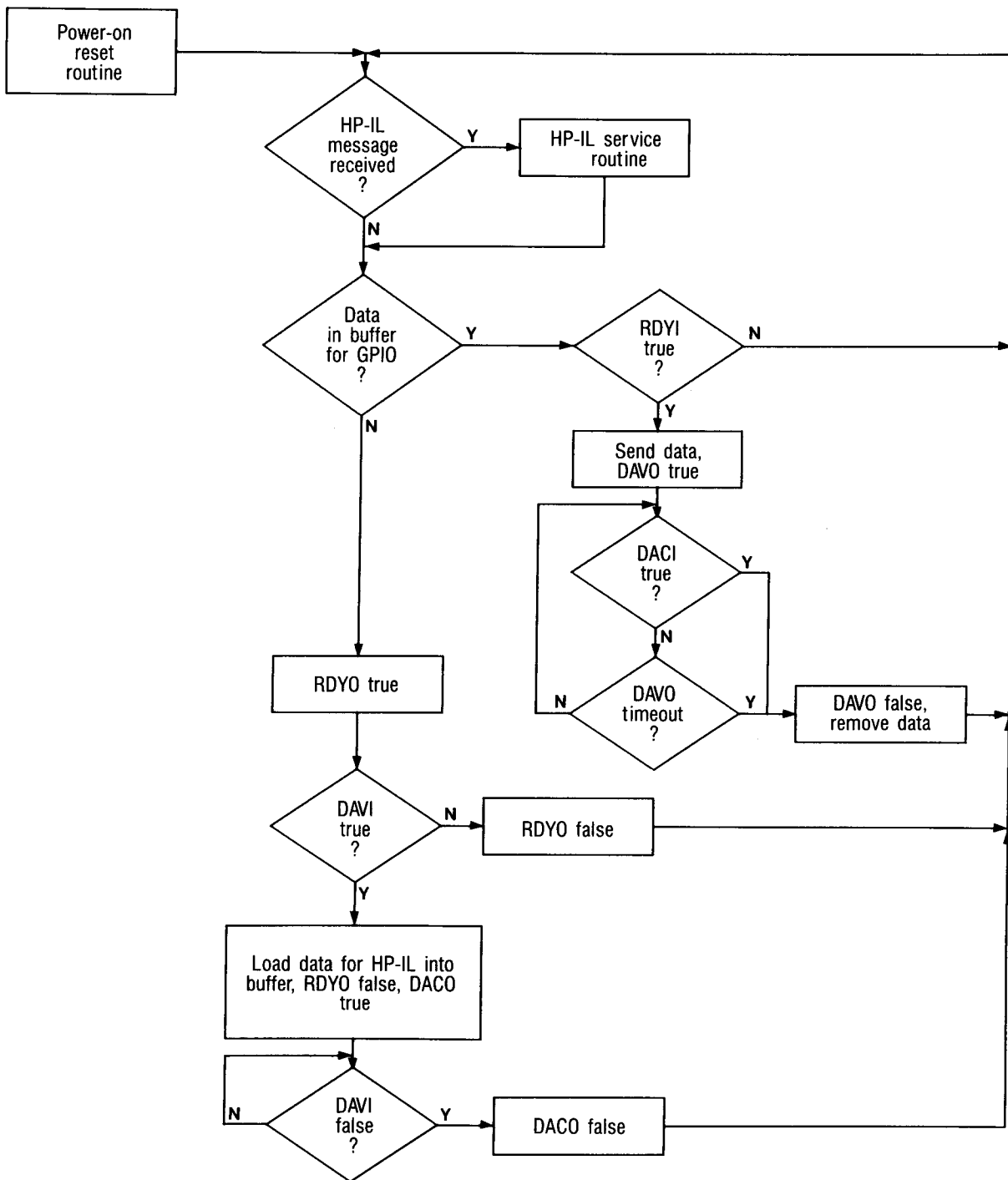

drive the DACI line true to indicate this. If the GPIO device does not drive the DACI line true immediately, the converter will simply wait until it does (unless the DAVO timeout option is enabled, as described previously). The GPIO device now holds the DACI line true until the converter removes the data and sets the DAVO line back to its false state (about 80 microseconds). Then the GPIO device can return the RDYI and DACI lines to the false state, thus completing the cycle. This should be done within about 50 microseconds after the DAVO line goes false so that the converter will not try to send a second byte on the same cycle.

In the valid/accepted handshake mode, the RDYI line is not used. When there is data in the buffer, the converter simply drives the data bus lines and the DAVO line true. The converter now waits until the GPIO device

signals acceptance of the byte by setting the DACI line true. (The DAVO timeout option may be used here, also.) The GPIO device holds the DACI line true until the converter removes the data and drives the DAVO line false again (about 80 microseconds). The GPIO device must return the DACI line to its false state within about 50 microseconds after the DAVO line goes false so that a second byte will not be sent on the same cycle. Note that if the GPIO device simply holds the RDYI line always true in the full handshake mode, the result is the same as the valid/accepted mode just described.

The DACI line is not used in the ready/valid handshake mode. The GPIO device simply sets the RDYI line true when it is ready to accept data. If there is data in the buffer there will be a delay (250 microseconds to 1 millisecond) and then the converter will drive the data bus lines and the DAVO line true. The DAVO line will remain true for a period of time determined by control registers R02-3 and R03. (There is no DAVO timeout option in this mode.) The GPIO device should return the RDYI line to its false state within about 50 microseconds after the DAVO line goes false to prevent a double byte transfer. If the GPIO device holds the DACI line always true in the full handshake mode, the result is the same as the ready/valid mode except for the length of the DAVO pulse.

Neither the RDYI line nor the DACI line are used in the strobed output mode. When there is data in the buffer the converter simply drives the data bus lines and the DAVO line true for a length of time determined by control registers R02-3 and R03. (There is no DAVO timeout option here, either.) If the GPIO device holds the RDYI line and the DACI line always true in the full handshake mode, the result is the same as the strobed output mode except for the length of the DAVO pulse.

Note: On the HP 82165A HP-IL/GPIO Interface only, the GPIO device should not use the leading edge of the DAVO line to latch data from the converter. The data is not valid until approximately 50 nanoseconds after the leading edge of the DAVO pulse. This does not apply to the HP 82166A HP-IL Converter.

If there is no data to be sent to the GPIO device, the microprocessor checks to see if the GPIO device wants to send data to HP-IL. It does this by driving the RDYO line true and then waiting a short time to see if the GPIO device drives the DAVI line true to indicate that the data on the data bus is valid. If the GPIO device does not respond, the converter returns the RDYO line to its normal false state and goes back to the top of the loop. Consequently, when no data is being transferred, a series of pulses will be transmitted on the RDYO line, one pulse each time the microprocessor passes through the polling loop. If there is data in the buffer to be sent to the GPIO device, there will be no RDYO pulses and the converter will not be able to receive data from the GPIO device.

After the GPIO device puts data on the bus and sets the DAVI line true in response to the RDYO pulse, the converter will load the data into the buffer and set the DACO line true and the RDYO line false. The GPIO device now returns the DAVI line to its false state and removes the data from the bus. At this point, the converter resets the DACO line to its false state and goes back to the top of the loop.

In order for the converter to recognize that the GPIO device wants to send data, the DAVI line must be true sometime during a time window starting at the leading edge of the RDYO pulse (about 60 microseconds). If the device does not set the DAVI line quickly enough, it will simply need to wait for the next RDYO pulse, holding the data and the DAVI line true until the converter drives the DACO line true.

The external device must use the RDYO line in order to know whether or not the converter can receive data. If the external device responds quickly enough to the RDYO pulse and carefully controls the length of time that it drives the data and the DAVI lines true, then it need not use the DACO line. However, it will generally be easier for the device to simply drive the data and the DAVI lines true when the RDYO line goes true and remove the data and set the DAVI line false when the DACO line goes true. This information should clarify the paragraphs near the bottom of page 7 (9), "GPIO Input Handshake Lines (RDYO, DAVI, DACO)" and on page 14 (17), "For HP-IL ← GPIO operations, ..." Refer to the input (HP-IL ← GPIO) timing characteristics in the table on page 19 (20).

Note that the microprocessor waits until the GPIO device removes its data and drives the DAVI line false before it returns the DACO line to its normal false state. If the GPIO device holds the DAVI line true and does not return it to the false state, the converter will wait indefinitely for this to happen. As before, HP-IL will not be functional while the GPIO device holds the converter in this state. There is no timeout option for this situation.

In the diagram at the bottom of page 15 (17), "HP-IL ← GPIO Operation," the blue arrow from the trailing edge of the DAVI pulse to the trailing edge of the RDYO pulse should be drawn from the leading edge of the DAVI pulse to the trailing edge of the RDYO pulse. Also, all the diagrams on page 15 (17) indicate the logical state of the handshake lines—not the voltage level. If negative handshake logic is active (the default condition), the true state (shown as high in the diagrams) corresponds to zero voltage, and the false state (low in the diagrams) corresponds to a positive voltage. If positive handshake logic is active, the logic levels shown in the diagram correspond to the actual voltage levels.

A lock-up condition can occur if a GPIO device using positive handshake logic is connected to the converter and is powered on before or at the same time as the converter. The GPIO device will power on with the DAVI line driven false (its normal condition), which is low. The converter powers on reading the low DAVI line as a true condition, however, and stops in the loop waiting for the DAVI line to go high (false). The control registers cannot be modified to remove the lock-up, since the program cannot return to the HP-IL service routine.

In order to use positive handshake logic, it is necessary to first set the control registers in the converter and then connect the GPIO device. An alternative is for the GPIO device to hold the DAVI line high until the converter control registers are properly set from HP-IL. Because of this, use of positive handshake logic may cause one invalid data byte to be accepted from the GPIO device at power-on only.

One other situation which can arise is best illustrated by considering two converters connected back-to-back on GPIO. If HP-IL writes, say, 40 bytes of data into the first converter, GPIO will transfer 31 bytes into the second converter's buffer, and 9 bytes will remain in the first converter's buffer to be sent later. Now if HP-IL writes some data into the second converter, the 31 bytes will be destroyed, and both converters will be locked up, waiting to send data to the other on GPIO. Neither can accept the other's data since the HP-IL data in the buffer prevents either converter from driving its RDYO line true. A clear buffer command or power-on reset is needed to recover from this situation. Unusual circumstances might also cause a similar condition to occur with a GPIO device and a converter. HP-IL continues to function in this case.

Additional Information

The following information applies to the HP 82165A HP-IL/GPIO Interface manual only:

On page (6) the box in the diagram should be labeled "HP-IL/GPIO Interface" rather than "HP-IL/RS-232 Interface".

On page (9) under "Power Supply," add the sentence "The interface is isolated from earth ground by the AC adapter."

On page (9) under "GPIO Output Handshake Lines (RDYI, DAVO, DACI)," the phrase "when DAVO is false, the data bus lines are high" should read "when DAVO is false, the data bus lines are undefined."

On page (10) under "HP-IL Interfacing Output Line (GETO)," the sentence "An active low signal on the GETO line sets a Group Execute Trigger message" should read "The GETO line is normally driven high by the interface. When an HP-IL Group Execute Trigger message is received, the interface pulses this line low briefly."

On page ¹⁰(11) the entry in the table next to "Ready for Command" should be "No response" rather than "Executes a pending Loop Power Down message."

On page (16) add the following note to the table at the top of the page, "In the eight-bit unidirectional configuration, data bus A receives data from the external device and data bus B sends data to the external device."

On page (19) under "Electrical Characteristics," the entry for "Voltage to Any Pin" should include a minimum of $-0.3V$. Also, delete the last four lines of the table, beginning with "Output Current, High Level."

The following information applies to the HP 82166A HP-IL Converter manual only:

On page 11 in the bottom table, the response for the Device Dependent Talker 0 message (Send Control Registers) should include the sentence "The transfer buffer is cleared." The response for the Device Dependent Talker 2 message (Enable End-Of-Line) should include the sentence "The GPIO end-of-line sequence must be the last data bytes in the buffer."

On page 18, under "Electrical Characteristics," the specification for "Supply Ripple Voltage" should be deleted. On page 29 under "Converter to Converter," the evaluation board has been changed to provide more convenient operation. Change the supply voltages in the second paragraph to 4.75 to 5.25 Vdc and 6 to 8 Vdc. Delete the caution—the evaluation board won't be damaged by operating it with less than two units connected. Revise the diagram of the board as shown below.

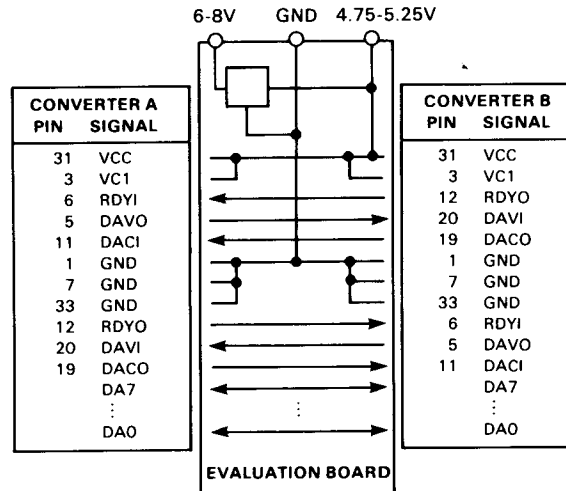

The following information applies to both manuals:

On page 13 (15) in the table, the designations "Bit 1", "Bit 2", etc. should be changed to "D0", "D1", etc.

On page 19 (20) in the lower timing diagram, the vertical line extending through the trailing edges of both RDYO and DACO should be two separate lines. The end of the RDYO pulse is not related to the end of the DACO pulse.

On page 36 (37) the last four lines in the program example should be numbered consecutively with the previous line.

HP 82165A HP-IL/GPIO Interface
HP 82166A HP-IL Converter
Manual Supplement



Corvallis Division
1000 N.E. Circle Blvd., Corvallis, OR 97330, U.S.A.